

# BACK 2 THE FUTURE

## Dual Change Cashless

Notes and Coins  
or Tokens Dispenser

As one of the most secure change machines on the market, the Dual Change Cashless provides convenience and safety to customers. Designed to accept contactless payment cards (debit or credit)\* and banknotes to dispense notes and coins or tokens\*.

### Features

- Notes and coins or Tokens dispensed automatically or manually
- Export accounting data and import configuration parameters via 32-bit CPU with SD-Card
- Internal on/off controls to prevent tampering
- Pivoting door to facilitate dispenser loading and cashbox removal operations
- Installation: wall mounted, countertop and free standing on a cabinet base

*\*Dependent on local legislation*



# Dual Change Cashless

## Notes and Coins or Tokens Dispenser

### Benefits

- Structural strength, reinforced closing mechanisms and ccTalk protocol make it one of the most secure change machines available
- Flexible coin or token dispensing options makes the machine user-friendly
- Upgradable to support banknotes

### Installed peripherals



Evolution hoppers with extensions



NV11 or NV10 banknote readers



Payter P66 Unit

**Tools**  
Multiconfig configuration software



### Technical Specifications

Dimensions (LxHxW)	400 x 1,620 x 409 mm
Weight	60 Kg
Power supply	230 Vac - 50 Hz
Power consumption	60 W max
Operating temperature	0°C ÷ 50 °C

### Technical Schematics

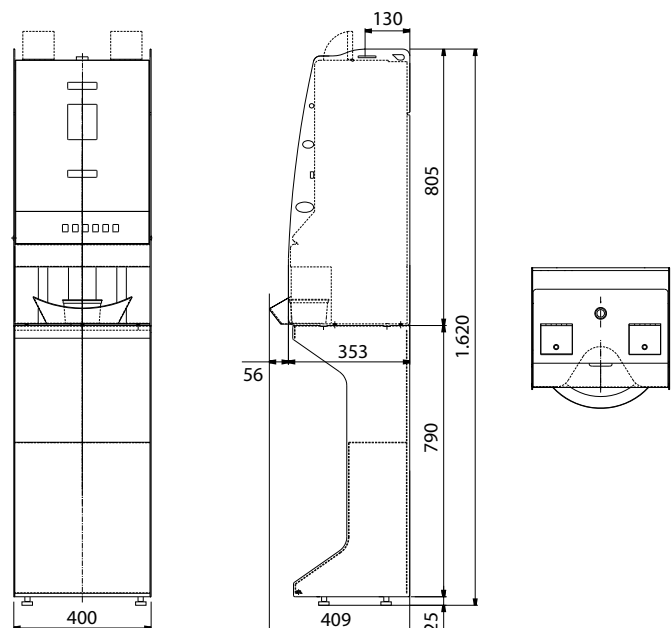

SUZOHAPP Netherlands B.V.

Rijnzathe 12, 3454 PV De Meern, The Netherlands - Phone: +31 (0)186 643333 - sales.nl@suzohapp.com