

# Easy PRO

Indoor change machines



The most versatile change machine

# The best-selling change machine

The 32-bit CPU provides functions normally present only on change machines of higher range and price, such as importing/exporting configuration parameters, exporting accounting data and the useful function of machine cloning.

The reinforced closing mechanisms make Easy PRO one of the most secure change machines on the market with respect to attempts of tampering and fraud. Easy PRO fits perfectly into all environments: shopping centres, gyms, airports, service stations, arcades, offices, bars and internet cafés.

## Features

- Connection of peripherals via ccTalk
- Distribution of coins or tokens. Bonus function for tokens
- Coins/tokens dispensed automatically or manually
- 32-bit CPU with SD-Card. Exporting of accounting data and importing of configuration parameters via SD-Card
- Machine cloning function
- Special cover for the dispenser's extension: prevents coins from falling out in the event that the machine is tipped over
- Holes in the cabinet for fastening the unit to other machines or to external structures such as columns or pillars
- Internal on/off controls to prevent tampering
- Pivoting door to facilitate dispenser-loading and cash box removal operations
- Wide range of installation options:
  - Wall mounted (thanks to the Easy UP kit)
  - Countertop
  - Wall mounted by means of 3 anchoring bolts to be inserted at the back of the device
  - Free-standing on its base (optional)

## Tools

### Multiconfig

Software to configure the change machine

## Installed peripherals

- Hopper Evolution
- NV9 USB+/NV10 USB+ banknote reader

## Optional peripherals

- RM5 HD coin validator

## Optional accessories

- Brain remote control device
- Kit for reinforcing change machines already in use
- Support base
- Easy UP installation kit
- Reprogrammable locks
- Steel protective bars

## Technical Schematics

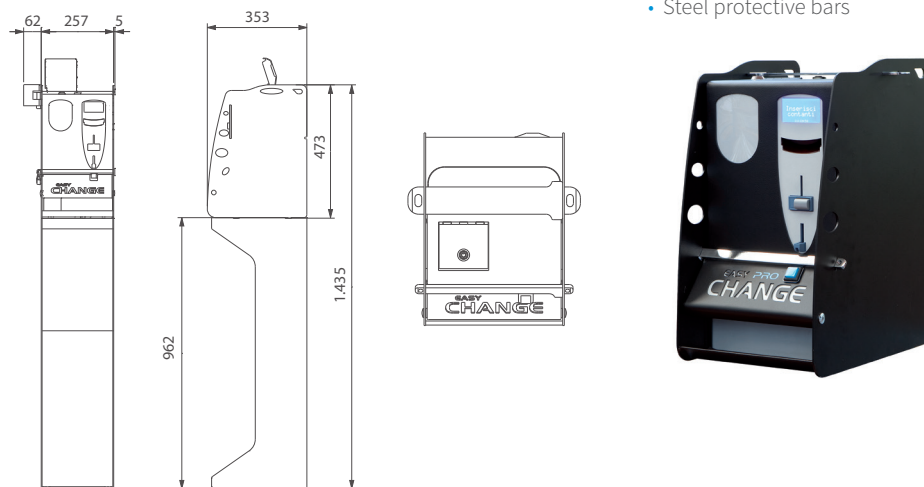

Note: Unit of measure: mm

## Technical Specifications

	Change machine	Change machine on support base
Dimensions (LxHxW)	257 x 473 x 353 mm	257 x 1,436 x 353 mm
Weight	25 kg	38 kg
Power supply	230 Vac - 50 Hz	230 Vac - 50 Hz
Power consumption	60 W max	60 W max
Operating temperature	3 °C ÷ 50 °C	3 °C ÷ 50 °C

## Coin Capacity

	0.5 €	1 €	2 €
1 Evolution hopper with extension	2,400	2,400	2,200
Cash box		1,600	