

Reel Topper

Model: 104-1XXXXXX

Manual

Version 1.4/June. 2010



SUZO  HAPP®

GAMING, AMUSEMENT AND INDUSTRIAL COMPONENTS

Antonie van Leeuwenhoekstraat 9
3261 LT Oud Beijerland
The Netherlands

Phone : +31(0)186-643333

Fax : +31(0)186-643322

Email : info@suzohapp.nl

Web : www.suzohapp.nl



1. Introduction

Congratulations with the purchase of your new reel topper. The topper houses three mini reel units, capable of being drive through commands given direct from the host machine. Each reel symbol can be illuminated through RGB LEDs giving versatile game design options.

1.1. Safety

1. This topper is only suitable for use in an interior environment where there are no particular requirements for resistance to dust or moisture (IP20).
2. It is not allowed to connect appliances to the topper which do not comply to SELV or Class II qualification.
3. To reduce the risk of electric shock, follow all safety notices and never open the topper case when power is connected.
4. Turn off the topper at the mains before cleaning.
5. The topper is equipped with a 3-wire, power cord. The power cord plug will only fit into a grounded outlet. Do not attempt to fit the plug into an outlet that has not been configured for this purpose. Do not use a damaged power cord.
6. The slots located on the backside of the topper case are for ventilation. Do not block or insert anything inside the ventilation slots.
7. It is important that your topper remains dry. Do not pour liquid into or onto the topper. If the topper internals become wet do not attempt to repair it yourself.
8. Unplug the topper from the power outlet before cleaning. Do not use alcohol (methyl, ethyl or isopropyl) or any strong dissolvent. Do not use thinner or benzene, abrasive cleaners or compressed air. To clean the topper, use a cloth lightly damped with a mild detergent.
9. For pluggable equipment, the socket-outlet shall be installed near the equipment and shall be easily accessible

Warning: This is a class A product. In a domestic environment this product may cause radio interference in which case the user may be required to take adequate measures.

1.2. Components

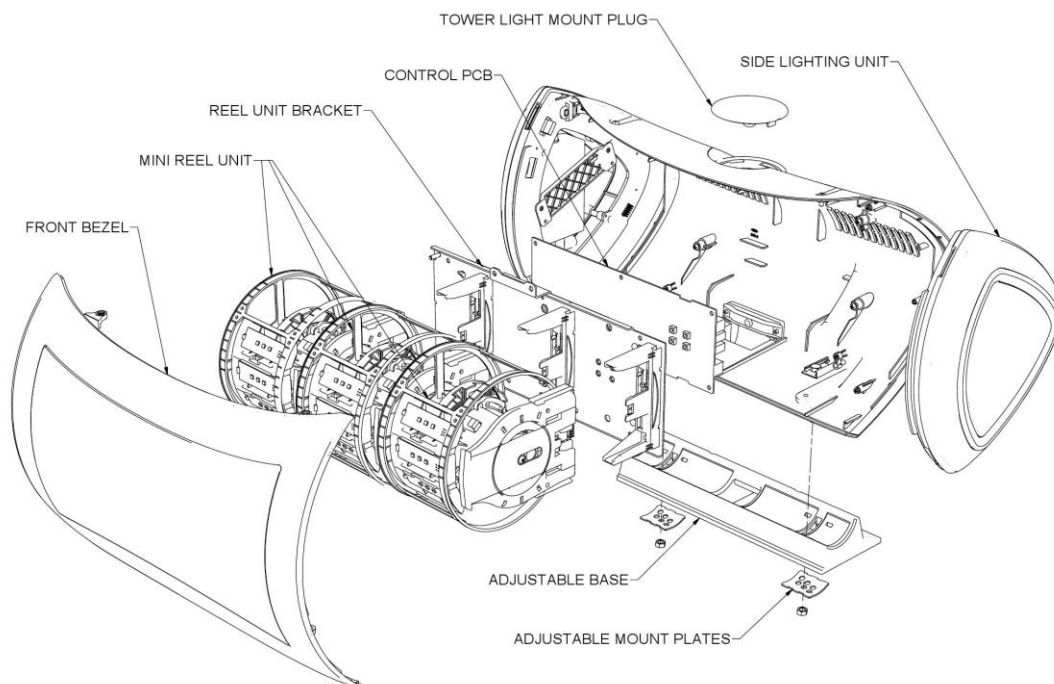

2. Installation and adjustment

2.1. Connecting the topper

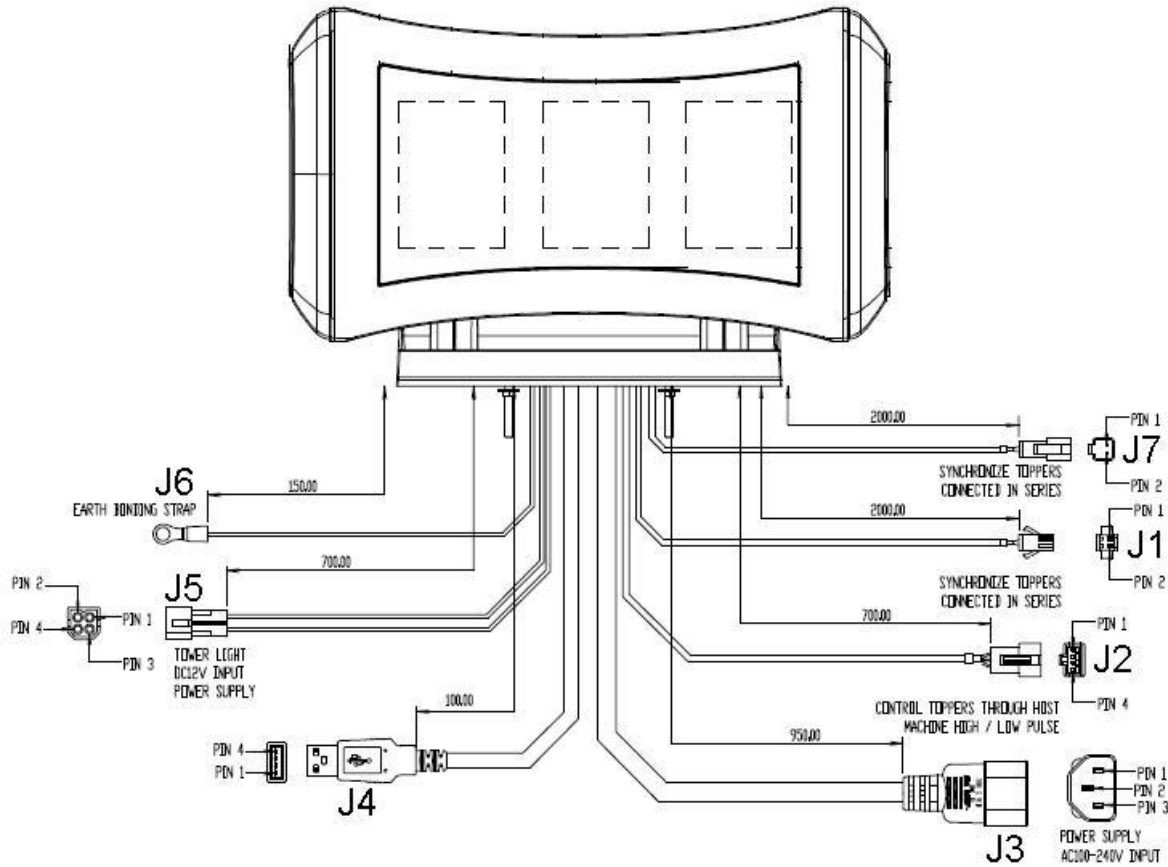

Connector	Function	Pin Number				Connector Type	
		1	2	3	4	Topper	Machine
J1	Synchronization	Ground	TXD/RXD				
	Wire Color	Black	White				
J2	Control	Ground	TXD	RXD	NC	JST P/N: SMR-04V-B	JST P/N: SMP-04V-B-C
	Wire Color	Black	White	Red	-		
J3	Power In	Live	Earth	Neutral			
J4	USB	USB +5V	D-	D+	Ground		
J5	Tower Light	Common	Lamp – 2nd from bottom	Lamp - bottom	Lamp – 3rd from bottom		
	Wire Color	Black	Yellow	White	Blue		
J6	Ground Wire	Earth Strap					
J7	Synchronization	Ground	TXD/RXD				
	Wire Color	Black	White				

2.2. Removing front bezel.

First remove the two flat head screws on the top of the Topper casing. When the screws are removed pull the top edge of the front bezel to carefully lift out.

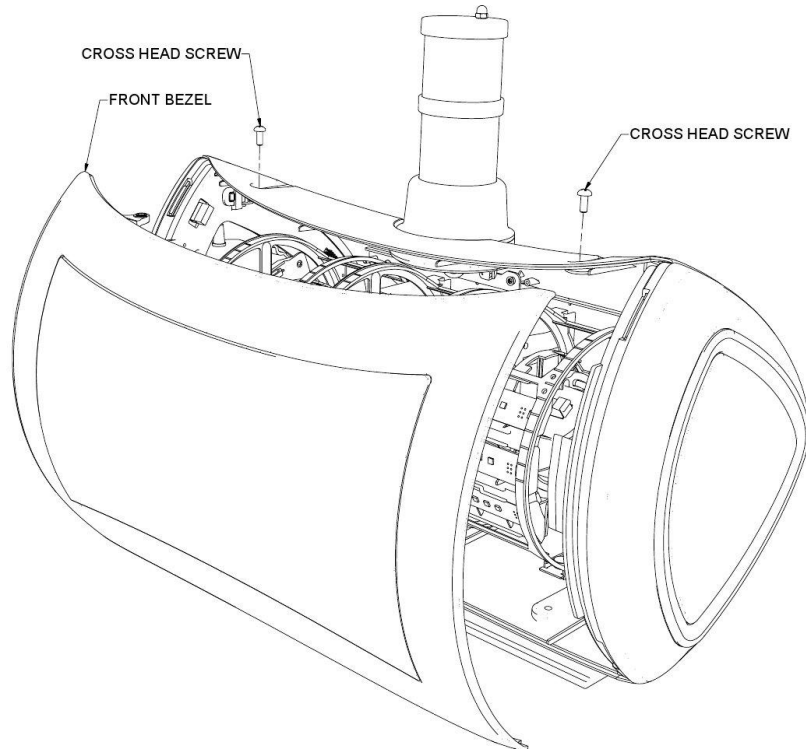

2.3. Adjusting the base

The base can be adjusted in 5 discrete positions. The Reel Topper can be mounted in a vertical position and under a 5 deg angle. Further angles are provided to achieve the same result with sloped cabinets. If a cabinet is sloped backwards 10deg you can still create a 5 deg overhang by using the 15 deg base setting.

The base can only be adjusted when the topper is not placed on the machine. There are two sliding metal plates which keep the base in place. If you want to adjust the base you have to unscrew the nut that keep both plates in place. You can now lift the base. When the base is lifted from the screws it becomes possible to move the metal plates sideways. The metal plates have 5 holes. Each hole results in a different base angle. The angles are noted next to the holes. You can see which angles are possible from the picture below

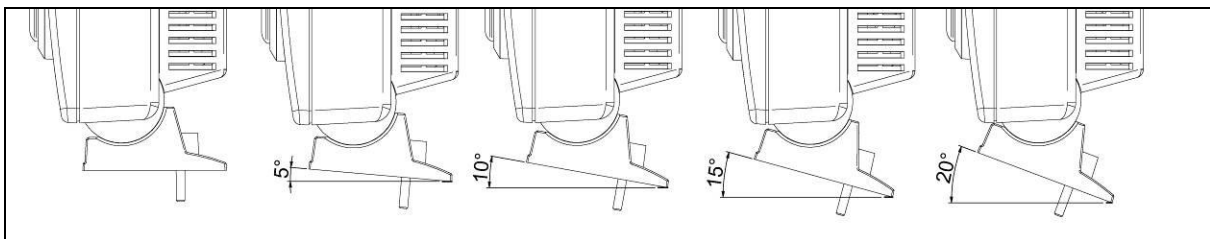
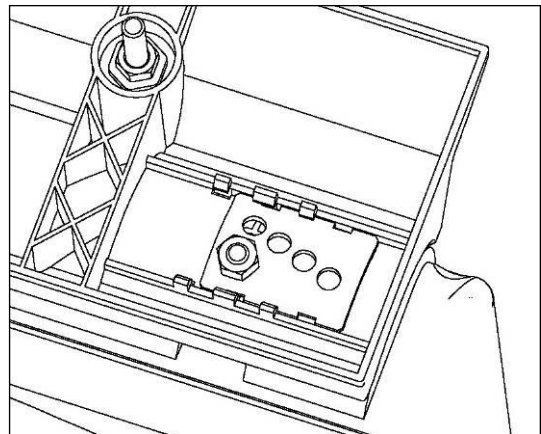

2.4. Reel band and viewing area size.

See drawing below for an approximation of the viewable area's and position of the reels.

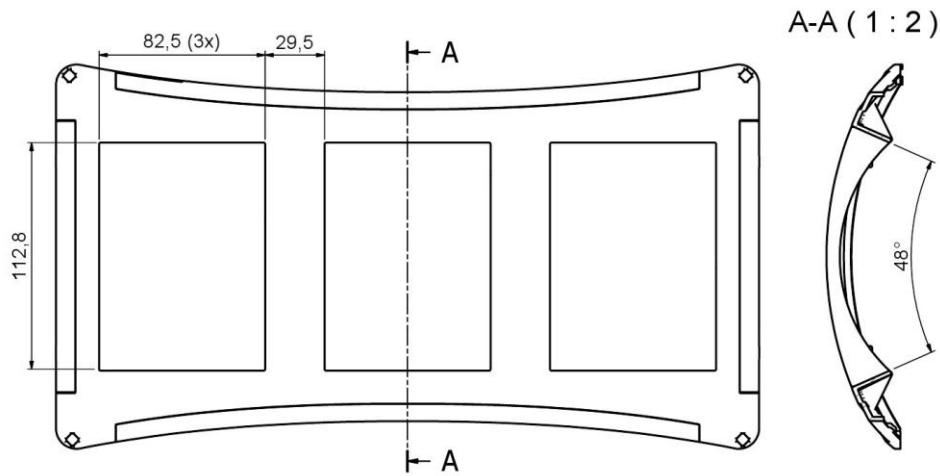

Reel band dimensions

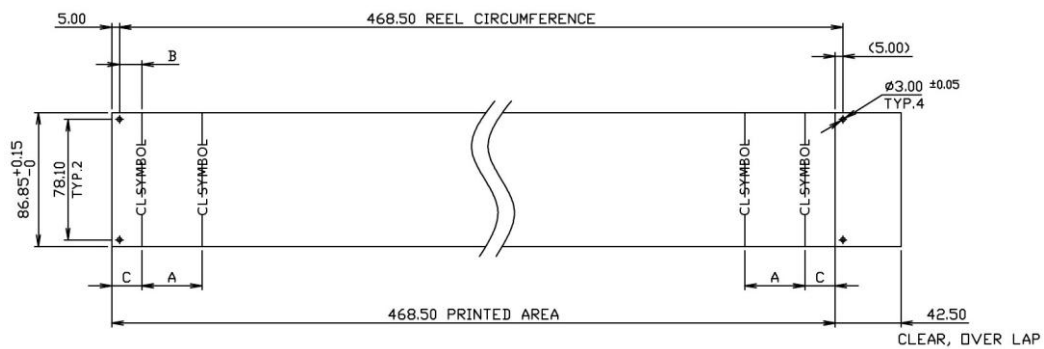

No. of symbols	DIM A	DIM B	DIM C
12	39,04	14,52	19,52
16	29,28	9,64	14,64

2.5. Tower light brackets

There are several plugs which fit the tower light hole at the rear of the reel topper. From left to right.

1. Lid closes the hole for when no tower light is used. There is a hook for easy retrieval of the tower light cable. Plug can be removed using a flat screw driver.
2. Horizontal mount plug. Mount the tower light on this and then mount the plug in the round topper. No need to open the topper to mount or service the tower light.
3. Slanted plug. For when the reel topper is mounted under a slight angle.

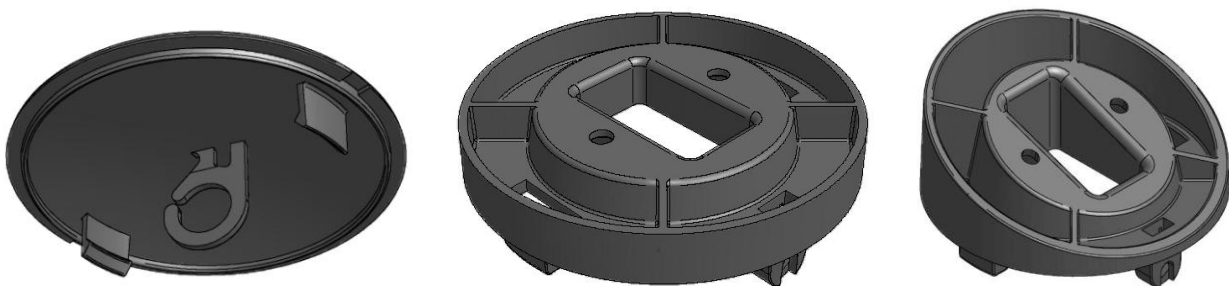

3. Software and topper control

3.1. General Specification

Feature	Description	Remarks
Reels	Maximum 5 reels (Maximum current per coil: 700mA)	
LEDs	Group A: Max. 150 RGB LEDs Group B: Max. 150 RGB LEDs Group C: Max. 15 RGB LEDs	
Connection interface	RS232, USB	
Network Option	RS232	Baud rate:9600 Data bits :8 Stop bits:1 Parity: None Hardware control: None RS232 Serial port
Power Supply	12VDC	
Demo program	Demo program with default LED and spinning pattern will automatically start 8 seconds after power up (without Host connected)	Host must communicate with topper within 8 seconds after power up to prevent starting of demo mode unintentionally.

3.2. Electric Specification

Absolute Maximum Ratings

Item	Unit	Min	Typical	Max	Remarks
Operating Temperature	°C	0	-	60	
Storage Temperature	°C	-30	-	80	
Relative Humidity	%		-	90	
Altitude	M	-	-	2000	

Input characteristic

Description	Signal	Unit	Min	Typical	Max	Remarks
Power in (12Vdc)						
	Input	12VDC	11.4	12	12,6	
	Consumption	Watt		50		
Power in (220Vac)						
	Input	Vac	100	-	240	
	Consumption	A		1		

3.3. Connections

Control board overview and connectors

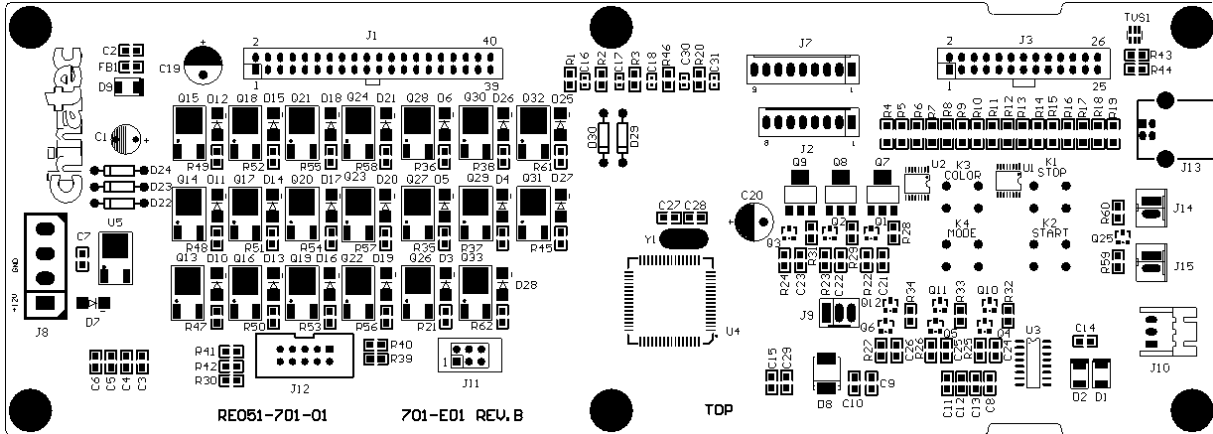

Connector	Description	Type
J1	Reel Motors and Opto Sensors (5 Reels)	40-Pin
J2	LEDs-A: 150 RGB	8-Pin
J3	Backlit for Reel (5 Reels X 3) or Pointer LED (5X)	26-Pin
J7	LEDs-B: 150 RGB	9-Pin
J8	Power Supply	4-Pin
J10	RS232 – Network Option	3-Pin
J11	ISP- Programming and field change	6-Pin
J12	Reserved for development / debug	10-Pin
J13	USB	USB Type-B R/A PCB
J14	Sync-in	2-Pin
J15	Sync-out	2-Pin

3.1. Command Format:

All commands are in following formats.

1 Byte	Start Byte (0XEF)
1 Byte	Command Byte
1 Byte	Number of Data Byte (N)
N Byte	Data Byte
1 Byte	Checksum Byte
1 Byte	Stop Byte (0XFE)

- Note- all commands are in hex format.
- Checksum = LSB (Number of Data Byte + Data Byte1+..+ Data ByteN)
- Topper will respond with an ACK or data after configuration is saved
- Topper will respond with a NAK if a fault is detected

Example1:

Cmd	No of data byte	Data byte	Action	Response
21	01	04	Set pattern 3 with color B/W/Y	ACK (65H)

Number of Data Byte = 01H;

Data Byte1 = 04H;

Checksum = LSB (Number of Data Byte + Data Byte1+..+ Data ByteN)=LSB(01 + 04) = 05

Example2:

Cmd	No of data byte	Data byte	Action	Response
05	08	81,00,00,F0,00,00,00,00	Spin reel 1 at 96rpm for 240 symbol clockwise	ACK (65H)

Number of Data Byte = 08H;

Data Byte1 = 81H;

Data Byte4 = F0H;

Checksum = LSB (Number of Data Byte + Data Byte1+..+ Data ByteN)
= LSB(08H+81H + F0H) = LSB(179H) = 79H

3.2. Command Summary:

Section	Command	Command No
5	Reel Functions	(01H-1EH)
5.1	Configure Reel Command	01H
5.2	Read / Write Ramp Table	02H
5.3	Set Duty Cycle	03H
5.4	Initialize (Synchronize) Reel	04H
5.5	Spin Reel	05H
5.6	Spin Reel LED – Pattern and Color	06H
5.7	Get Reel Status	07H
5.8	Tilt / Nudge	08H
5.9	Sound Synchronize enable	09H
6	LED Functions	
6.1	Commands on Bezel	(1FH-50H)
6.1.1	Pattern Mode	1FH-2DH
7	System Commands	
7.1	Commands from Host	(51H-64H)
7.1.1	Set Topper Number (Slave Address)	51H
7.1.2	Get Firmware Revision	52H
7.1.3	Set Active Topper	53H
7.1.4	Clear Reset Flag	54H
7.1.5	Factory Default	55H
7.1.6	Get Topper Number	56H
7.2	Commands Response from Topper to Host	(65H-78H)
7.2.1	ACK	65H
7.2.2	NAK	66H
7.2.3	Transmit a reel sound synch report to Host	67H
7.2.4	Return Reel Position to Host	68H
7.2.5	Return Firmware revision to Host	69H
7.2.6	Return Ramp Value to Host	6AH
7.2.7	Request to set Topper Number	6BH
7.2.8	Return Topper Number to Host	6CH
8	Synchronize Commands	(79H-82H)
8.1	Synchronize LED Pattern and Color	79H

3.3. Reel Functions (command 01H-1EH)

Configure Reel Command (Save to EEPROM)

Command Byte	Command	Number of Data Byte
01H	Configure Reel Command	1

Data Byte:

D7	D6	D5	D4	D3	D2	D1	D0	
Topper Type		Symbol Number			Number of Reels Fitted			
0	0							Reel
0	1							Disc - RGB
1	0							Disc - White LED
1	1							Spare
		0	0	0				12-Reel Topper
		0	0	1				22-Disc Topper
		010 - 111						Spare
					1H - 5H			Number of motors fitted
					6H - 7H			Spare

(Default values set by factory)

Read / Write Ramp Table (Save to EEPROM)

Command Byte	Command	Number of Data Byte
02H	Read / Write Ramp Table	3 (Write) / 2 (Read)

Data Byte 1 – Ramp Table Type

D7	D6	D5	D4	D3	D2	D1	D0		
1=write 0=read	D0 to D6 = ramp table type 0H to 20H are preset tables, for read only								0H to 7FH available for ramp tables: 0H = reel topper 96rpm 1H = reel topper 30rpm 2H = reel topper 1 symbol nudge 3H to 0FH reserved for future use 10H = disc rear motor 100rpm 11H = disc front motor 37rpm 12H = disc front motor 43rpm 13H = disc front motor 50rpm 14H = disc rear motor 1 symbol nudge 15H = disc front motor 1 symbol nudge 16H to 20H reserved for future use 21H to 40H = for customer use (32 address)

Data Byte 2 – Ramp Position

D7	D6	D5	D4	D3	D2	D1	D0	
Ramp position capability 0H = run ramp address 1H – FH = up ramp address (default values are is FF) 80H–8FH = down ramp address(default values are is FF) Values at other address is 00H								customer usable range for spin 0H = run ramp address 1H – FH = up ramp address (15 location) 80H-8FH = down ramp address (16 location)

Data Byte 3 – Ramp Value (mS)

D7	D6	D5	D4	D3	D2	D1	D0	
Value = 0.5mS / bit								range 1H – 0FFH (0.5 mS to 127 mS)

- If command is Read, this byte can be ignored
- If command is Read, topper to return ramp value (time) to host through command 6AH
- If command is Write, it will be good practice to add 0ms after the last ramp value. The host will stop reading after 0. This is to avoid reading previous input ramp value. For example, input ramp values as 34,24,13,16,0.

Set Duty Cycle (Save to EEPROM)

Command Byte	Command	Number of Data Byte
03H	Set Duty Cycle	2

Data Byte 1 – Motor Number

D7	D6	D5	D4	D3	D2	D1	D0	
							1	Reel 1 / Small disc
						1		Reel 2 / Large disc
					1			Reel 3
				1				Reel 4
			1					Reel 5
		1						All fitted

Data Byte 2 – Period

D7	D6	D5	D4	D3	D2	D1	D0	
D4 – D7 = period Period range 10H to 0F0H = 2mS to 30mS (2,4,8...30)				D0 – D3 = on time On timer range 1H to 0FH = 1mS to 15mS (1,2,3...15)				Period: 1bit = 2mS On-time: 1 bit = 1mS period must be > or = on time

Initialize (Synchronize) Reel

Command Byte	Command	Number of Data Byte
04H	Initialize (Synchronize) Reel	1

Data Byte

D7	D6	D5	D4	D3	D2	D1	D0	
							1	Reset Reel 1 / Small disc
						1		Reset Reel 2 / Large disc
					1			Reset Reel 3
				1				Reset Reel 4
			1					Reset Reel 5
		1						Reset all fitted

Spin reel

Command Byte	Command	Number of Data Byte
05H	Spin Reel	8

Data Byte 1 – Motor number

D7	D6	D5	D4	D3	D2	D1	D0	
							1	Reel 1 / Small disc
						1		Reel 2 / Large disc
					1			Reel 3
				1				Reel 4
			1					Reel 5
		1						All fitted (for reel topper only)
1								Hi = forward, low = reverse

Data Byte 2 – Speed selection

D7	D6	D5	D4	D3	D2	D1	D0	
D0 to D6 = ramp table type								0H to 7FH available for ramp tables: 0H = reel topper 96rpm 1H = reel topper 30rpm 2H = reel topper 1 symbol nudge 3H to 0FH reserved for future use 10H = disc rear motor 100rpm 11H = disc front motor 37rpm 12H = disc front motor 43rpm 13H = disc front motor 50rpm 14H = disc rear motor 1 symbol nudge 15H = disc front motor 1 symbol nudge 16H to 20H reserved for future use 21H to 40H = for customer use

Data Byte 3 – Spin distance (symbols) upper byte

D7	D6	D5	D4	D3	D2	D1	D0	
Symbol number; range 0 to FF								

Data Byte 4 – Spin distance (symbols) lower byte

D7	D6	D5	D4	D3	D2	D1	D0	
Symbol number; range 0 to FF								

Data Byte 5 – Symbol LED status at start of spin

D7	D6	D5	D4	D3	D2	D1	D0	
							1	Reel 1 top
						1		Reel 1 middle
					1			Reel 1 bottom
				1				Reel 2 top
			1					Reel 2 middle
		1						Reel 2 bottom
	1							Reel 3 top
1								Reel 3 middle

Data Byte 6 – Symbol LED status at start of spin

D7	D6	D5	D4	D3	D2	D1	D0	
							1	Reel 3 bottom
						1		Reel 4 top
					1			Reel 4 middle
				1				Reel 4 bottom
			1					Reel 5 top
		1						Reel 5 middle
	1							Reel 5 bottom

Data Byte 7 – Symbol LED status at end of spin

D7	D6	D5	D4	D3	D2	D1	D0	
							1	Reel 1 top
						1		Reel 1 middle
					1			Reel 1 bottom
				1				Reel 2 top
			1					Reel 2 middle
		1						Reel 2 bottom
	1							Reel 3 top
1								Reel 3 middle

Data Byte 8 –Symbol LED status at end of spin

D7	D6	D5	D4	D3	D2	D1	D0	
							1	Reel 3 bottom
						1		Reel 4 top
					1			Reel 4 middle
				1				Reel 4 bottom
			1					Reel 5 top
		1						Reel 5 middle
	1							Reel 5 bottom

Transmit a reel sound synch report when each reel stops (if command 09H is enabled) - [Command 67H]

Spin Reel LED – Pattern and Color (Save to EEPROM)

Command Byte	Command	Number of Data Byte
06H	Spin Reel LED	7

Data Byte 1 – Spin Reel LED Pattern

D7	D6	D5	D4	D3	D2	D1	D0	
Pattern at end of spin 10H-80H				Pattern at start of spin 0H-7H				Pattern 1 – Pattern 8: 0: Reel LED Solid color 1: Flashing rate = 0.5 sec 2: Flashing rate = 1.0 sec 3: Flashing rate = 1.5 sec 4: Flashing rate = 2.0 sec 5: Flashing rate = 2.5 sec 6: Flashing rate = 3.0 sec 7: Flashing rate = 10 sec

Note: Ignore color option if multi-color pattern is selected

Data Byte 2 –Spin Reel LED color

D7	D6	D5	D4	D3	D2	D1	D0	
							1	LED1-R reel 1 top symbol / pointer 1
						1		LED1-G reel 1 top symbol / pointer 1
					1			LED1-B reel 1 top symbol / pointer 1
				1				LED2-R reel 1 middle symbol / pointer 2
			1					LED2-G reel 1 middle symbol / pointer 2
		1						LED2-B reel 1 middle symbol / pointer 2
	1							LED3-R reel 1 bottom symbol / pointer 3
1								LED3-G reel 1 bottom symbol / pointer 3

Data Byte 3 –Spin Reel LED color

D7	D6	D5	D4	D3	D2	D1	D0	
							1	LED3-B reel 1 bottom symbol / pointer 3
						1		LED4-R reel 2 top symbol / pointer 4
					1			LED4-G reel 2 top symbol / pointer 4
				1				LED4-B reel 2 top symbol / pointer 4
			1					LED5-R reel 2 middle symbol / pointer 5
		1						LED5-G reel 2 middle symbol / pointer 5
	1							LED5-B reel 2 middle symbol / pointer 5
1								LED6-R reel 2 bottom symbol

Data Byte 4 –Spin Reel LED color

D7	D6	D5	D4	D3	D2	D1	D0	
							1	LED6-G reel 2 bottom symbol
						1		LED6-B reel 2 bottom symbol
					1			LED7-R reel 3 top symbol
				1				LED7-G reel 3 top symbol
			1					LED7-B reel 3 top symbol
		1						LED8-R reel 3 middle symbol
	1							LED8-G reel 3 middle symbol
1								LED8-B reel 3 middle symbol

Data Byte 5 –Spin Reel LED color

D7	D6	D5	D4	D3	D2	D1	D0	
							1	LED9-R reel 3 bottom symbol
						1		LED9-G reel 3 bottom symbol
					1			LED9-B reel 3 bottom symbol
				1				LED10-R reel 4 top symbol
			1					LED10-G reel 4 top symbol
		1						LED10-B reel 4 top symbol
	1							LED11-R reel 4 middle symbol
1								LED11-G reel 4 middle symbol

Data Byte 6 –Spin Reel LED color

D7	D6	D5	D4	D3	D2	D1	D0	
							1	LED11-B reel 4 middle symbol
						1		LED12-R reel 4 bottom symbol
					1			LED12-G reel 4 bottom symbol
				1				LED12-B reel 4 bottom symbol
		1						LED13-R reel 5 top symbol
		1						LED13-G reel 5 top symbol
	1							LED13-B reel 5 top symbol
1								LED14-R reel 5 middle symbol

Data Byte 7 –Spin Reel LED color

D7	D6	D5	D4	D3	D2	D1	D0	
							1	LED14-G reel 5 middle symbol
						1		LED14-B reel 5 middle symbol
					1			LED15-R reel 5 bottom symbol
				1				LED15-G reel 5 bottom symbol
			1					LED15-B reel 5 bottom symbol

Get Reel Status

Command Byte	Command	Number of Data Byte
07H	Get Reel Status	1

Data Byte 1 – Motor Number

D7	D6	D5	D4	D3	D2	D1	D0	
							1	Reel 1 / Small disc
						1		Reel 2 / Large disc
					1			Reel 3
				1				Reel 4
			1					Reel 5

- Topper to return Reel position (Symbol number on pay line) to Host - [command 68H]

Tilt (at 30 rpm) / Nudge (1 symbol) Command

Command Byte	Command	Number of Data Byte
08H	Tilt (at 30 rpm) / Nudge (1 symbol)	1

Data Byte 1 – Motor Number

D7	D6	D5	D4	D3	D2	D1	D0
0H= tilt reel 1 / small disc 1H= tilt reel 2 / large disc 2H= tilt reel 3 3H= tilt reel 4 4H= tilt reel 5 5H= tilt all (can be 2 x disc motors, or 5 x reel motors) 6H To 0FH = spare 10H= nudge reel 1 forward / small disc clockwise 11H= nudge reel 1 reverse / small disc counter clockwise 12H= nudge reel 2 forward / large disc clockwise 13H= nudge reel 2 reverse / large disc counter clockwise 14H= nudge reel 3 forward 15H= nudge reel 3 reverse 16H= nudge reel 4 forward 17H= nudge reel 4 reverse 18H= nudge reel 5 forward 19H= nudge reel 5 reverse 1AH= nudge all forward 1BH= nudge all reverse 1AH to 0FFH = spare							

- This command is continuous spin until following commands are received,
 - Configure reel (01H)
 - Read / write ramp table (02H)
 - Set duty cycle (03H)
 - Initialize reel (04H)
 - Set topper number (51H)
 - Factory default (55H)
- Respond NAK and fault code for all other commands received.

Sound synchronize enable (Save to EEPROM)

Command Byte	Command	Number of Data Byte
09H	Sound synchronize enable	1

Data Byte

D7	D6	D5	D4	D3	D2	D1	D0
0H=disable 1H=enable							

3.4. LED Functions (command on bezel: 1FH-50H)

Commands on Bezel

Pattern Mode (Save to EEPROM)

Command Byte	Command	Number of Data Byte
1FH-2DH	Pattern Mode	1

Data Byte 1 – Color

D7	D6	D5	D4	D3	D2	D1	D0	Remarks
0X01=R/W/B								1FH=pattern1
0X02=R/W/G								20H=pattern2
0X03=R/W/Y								21H=pattern3
0X04=B/W/Y								22H=pattern4
0X05=B/W/P								23H=pattern5
0X06=G/Y/B								24H=pattern6
0X07=B/G/R								25H=pattern7
0X08= Red								26H=pattern8
0X09= Yellow								27H=pattern9
0X0A= Green								28H=pattern10
0X0B= Blue								29H=pattern11
0X0C= Purple								2AH=pattern12
0X0D= White								2BH=pattern13
								2CH= Turn all LEDs Off
								2DH= Turn all LEDs On

Notes:

- R – Red / W – White / B – Blue / G – Green / Y – Yellow / P – Purple
- Pattern 1-13 applicable to RGB bezel and pattern 1-7 applicable to STD LED bezel.
- Command 2CH and 2DH will turn all LEDs off and on, including LEDs for Reels / Pointers

3.5. System Functions

Commands from Host (command 51H-64H)

Set Topper number (Slave Address) (Save to EEPROM)

Command Byte	Command	Number of Data Byte
51H	Set topper number	1

Data Byte 1 –Slave Address

D7	D6	D5	D4	D3	D2	D1	D0	Remarks
Topper number: range 0H to 0FEH								Topper number write to EEPROM 0H = master

Get Firmware revision

Command Byte	Command	Number of Data Byte
52H	Get Firmware revision	0

- Topper to return firmware revision to Host - [command 69H]

Set Active Topper

Command Byte	Command	Number of Data Byte
53H	Set Active Topper	1

Data Byte 1 –Topper number

D7	D6	D5	D4	D3	D2	D1	D0	Remarks
Topper number: range 0 to FE								
FF – All fitted topper								Broadcast command

Clear Reset Flag

Command Byte	Command	Number of Data Byte
54H	Clear Reset Flag	0

Factory Default

Command Byte	Command	Number of Data Byte
55H	Factory Default	0

- This command resets all default values, clears customer values and sets topper address to FFH.

Get Topper Number

Command Byte	Command	Number of Data Byte
56H	Get topper number	0

- Topper to return topper number to Host by command 6CH

Commands Response from Topper to Host (command 65H-78H)

ACK

Command Byte	Command	Number of Data Byte
65H	ACK	0

NAK

Command Byte	Command	Number of Data Byte
66H	NAK	1

Data Byte –The topper will respond with a NAK and a fault code if the command cannot be executed

D7	D6	D5	D4	D3	D2	D1	D0
0H=reset flag has not been cleared 1H=data out of range 2H=message length out of range 3H=checksum incorrect 4H=communications time out 5H=reel busy 6H=reel not configured 7H=movement detection at standstill reel / disc 1 8H=movement detection at standstill reel / disc 2 9H=movement detection at standstill reel 3 0AH=movement detection at standstill reel 4 0BH=movement detection at standstill reel 5 0CH=tilt reel 1 / small disc 0DH=tilt reel 2 / large disc 0EH=tilt reel 3 0FH=tilt reel 4 10H=tilt reel 5 11H=opto fault reel / small disc 12H=opto fault reel / large disc 13H=opto fault reel 3 14H=opto fault reel 4 15H=opto fault reel 5 16H=write error 17H=USB timeout 18H=topper number already set 19H=topper synch error (more fault messages may be required for USB)							

Transmit a reel sound synch report to Host when each reel stops

Command Byte	Command	Number of Data Byte
67H	Transmit a reel sound synch report to Host when each reel stops	1

Data Byte 1 – Motor Number

D7	D6	D5	D4	D3	D2	D1	D0	
							1	Reel 1 / Small disc
						1		Reel 2 / Large disc
					1			Reel 3
				1				Reel 4
			1					Reel 5

Topper to return Reel position in terms of Symbol number to Host

Command Byte	Command	Number of Data Byte
68H	Topper to return Reel position in terms of Symbol number to Host	1

Data Byte 1 – Symbol Position on payline

D7	D6	D5	D4	D3	D2	D1	D0	
reels - range is 1 - 12 (1H to 0CH)								
discs - range is 1 - 22 (1H to 16H)								

Return Firmware revision to Host

Command Byte	Command	Number of Data Byte
69H	Return Firmware revision to Host	1

Data Byte 1 - Firmware revision

D7	D6	D5	D4	D3	D2	D1	D0	
Firmware revision: from 01 to 255 (01H to FFH)								

Return Ramp Value (time) to host

Command Byte	Command	Number of Data Byte
6AH	Return Ramp value (time) to host	1

Data Byte1

D7	D6	D5	D4	D3	D2	D1	D0	
0.5mS / bit								

Request to set topper number

Command Byte	Command	Number of Data Byte
6BH	Request to set topper number	1

Data Byte 1 –Current topper number

D7	D6	D5	D4	D3	D2	D1	D0	
Topper number: range 0H to 0FFH								FFH – default topper number 0H = master

- If topper number is FFH (default value), this command will be sent to host after power up.

Return Topper Number to Host

Command Byte	Command	Number of Data Byte
6CH	Return topper number to host	1

Data Byte1

D7	D6	D5	D4	D3	D2	D1	D0	
Topper number: range 0H to 0FFH								FFH – default topper number 0H = master topper

3.6. Programming Logics

Power Up

- On power up, topper should
 - Set reset flag.
 - Initialize reels / discs to home position
 - Enter standstill mode (with duty cycle set by customer, or default value if customer not set)
 - Wait for customer to send 'clear reset flag' command to topper
- The host should send a clear reset flag command to clear the flag.
- If customer sends any other command, topper responds NAK with error code 0H
- If a power failure occurs the flag would be reset, and the MPU can recognize a failure occurred, then send a NAK with fault code when host sends next command.
- Topper needs a 'clear reset flag' command to resume operation.
- Host should send this command before other commands can be sent.

Set Topper Number

- Default topper number is set to 255 (FFH) (off-factory setting).
- Once the topper is connected to Host and complete action mentioned in 8.1, topper will send command 6CH to Host asking for setting the topper number if topper number is 255.
- Host will send command 51H to set the topper number.
- Topper number 0 will be the master for synchronization.

Set Active Topper

- All toppers connected to Host must be set with topper number (0-254).
- Host can communicate with specific topper through command 53H (Set Active Topper) until another topper is set active.
- Host can also broadcast commands to all fitted toppers through command 53H.

Timing between two commands

- Timing between two commands should be 0.3 second minimum. Data will be clear if nothing received within 0.3 second.

Order of commands from host on power up, for system initialization

- A. Clear reset flag
- B. Firmware rev (optional)
- C. Configure reels if different from default values (optional)
- D. Set ramp tables if different from default values (optional)
- E. Synchronize reels
- F. Reel status (optional)

Convention - Unit positions

- Reel Topper – view on front of unit

Reel 1	Reel 2	Reel 3	Reel 4	Reel 5
--------	--------	--------	--------	--------

- Disc Topper – view on front of unit

rear motor, small disc is disc 1
front motor, large disc is disc 2

Resolution

- 0.5ms

4. Measurements

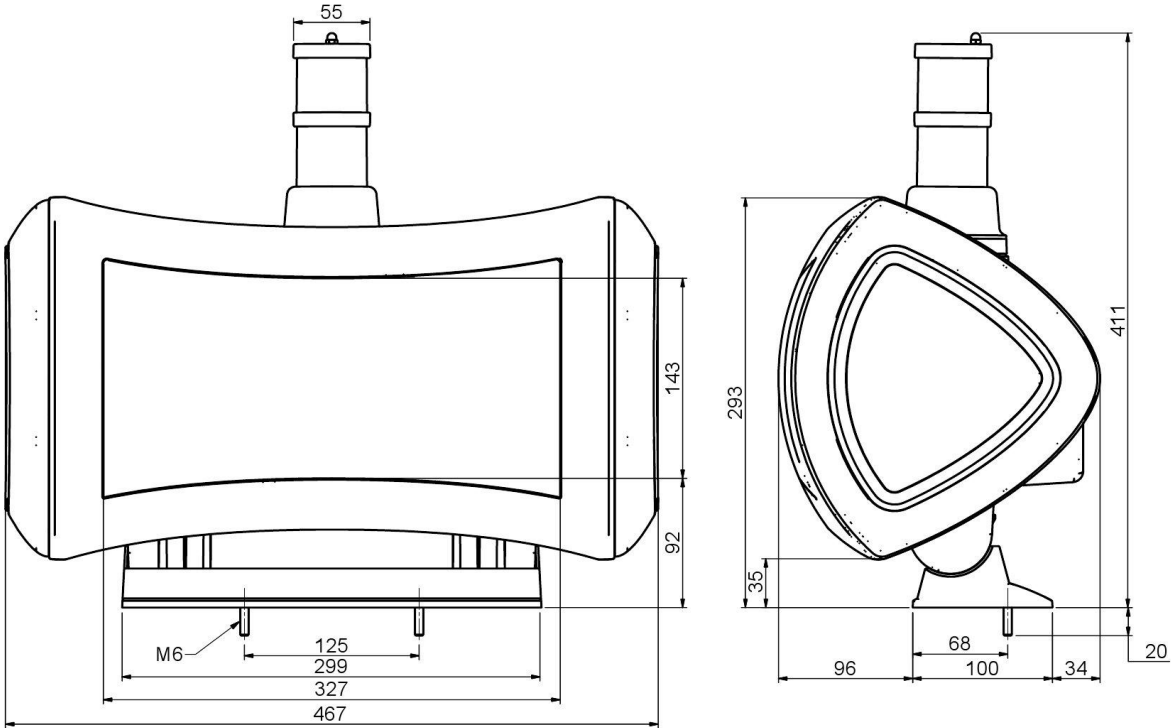

5. Declarations

EC Declaration of Conformity

We, the undersigned

Applicant: DYNAMICS CHINATEC INDUSTRIES (HK) LTD.
Address, City: 809-810 Block A, Hoi Luen Ind. Ctr., 55 Hoi Yuen Road, Kwun Tong, Kowloon, Hong Kong.
Country/Region: China

Manufacturer: DYNAMICS CHINATEC INDUSTRIES (HK) LTD.
Address, City: 809-810 Block A, Hoi Luen Ind. Ctr., 55 Hoi Yuen Road, Kwun Tong, Kowloon, Hong Kong.
Country/Region: China

Authorized representative in Europe:
Address, City:
Country:

certify and declare under our sole responsibility that the following apparatus:

EUT Description: REEL TOPPER
Manufacturer: DYNAMICS CHINATEC INDUSTRIES (HK) LTD.
Brand/Trade name: N/A
Model Number: 104-1XXX

conforms with the essential requirements of the EMC Directive 2004/108/EC, based on the following specification(s) applied:

EN 55022:2006+A1:2007
 EN 55024:1998+A1:2001+A2:2003
 EN 61000-3-2:2006
 EN 61000-3-3:2008

and therefore compiles with essential requirements and provisions of the EMC Directive. Further information refers to Technical Documentation kept by manufacturer or authorized representative. The CE mark can be affixed on the product (s) by declarer when other applicable directives also are observed.

Manufacturer Applicant
 Authorized representative

Name: T/R No.: DC201000031
 Title: DoC No.: 008DC201000031

Signature:  

Date: 26 MAR 2010

CE

 Guangzhou GRG Metrology and Test Technology Co., Ltd.
 Accreditation/assessment in accordance with EN 45001 and ISO/IEC 17025
 Signature: Mr. Frank Chen 
 Date: Feb 8th, 2010 



HONG KONG STANDARDS AND TESTING CENTRE
EC DECLARATION OF CONFORMITY

Reference Number: LVD1004913

Dynamics Chinatec Industries (HK) Ltd.
 809-810 Block A, Hoi Luen Ind. Ctr., 55 Hoi Yuen Road,
 Kwun Tong, Kowloon, Hong Kong.

declare the product

Description: Reel Topper
 Brand Name: **SUZOHAPP**
 Model: 104-10800000

complies with the requirements of the
EC Low Voltage Directive 2006/95/EEC

Applicable Standard(s) with amendments:
 EN 60950-1: 2006

General Remarks:

This declaration is only valid when used in conjunction with the technical file(s) refers to HE156654.
 This declaration applies specifically to the sample(s) investigated in the technical report mentioned above and not to the bulk.

The CE marking as shown below can be affixed on the product after preparation of necessary conformity documentation, as stipulated in Annex III of the Council Directive 93/68/EEC.

Manufacturer/Importer

Signature



Test Laboratory

CHAN Ka Chun, Vincent
 Authorized Signatory
 Electrical Safety Department
 For and on behalf of
 Hong Kong Standards and Testing Centre



www.stc-group.org

Date of Issue: 2010-05-24