

REVISION HISTORY			
REV	DESCRIPTION	DATE	APPROVED
00	INITIAL RELEASE	12-7-2017	Maarten

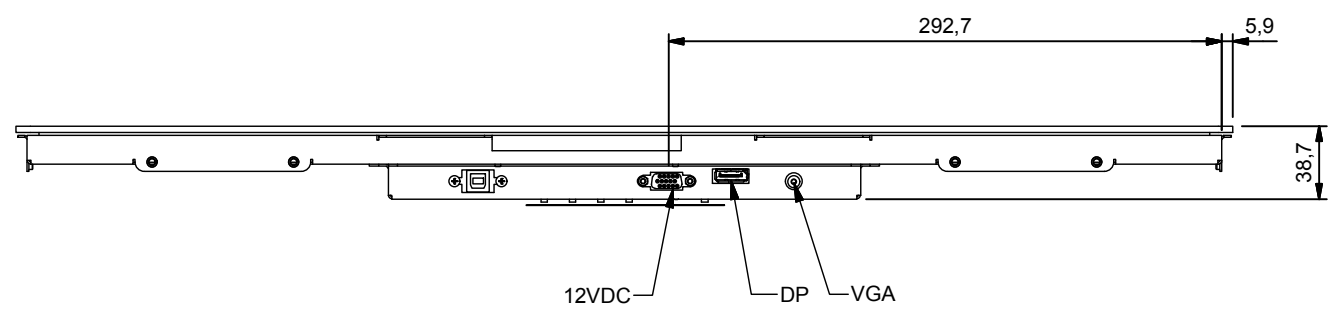
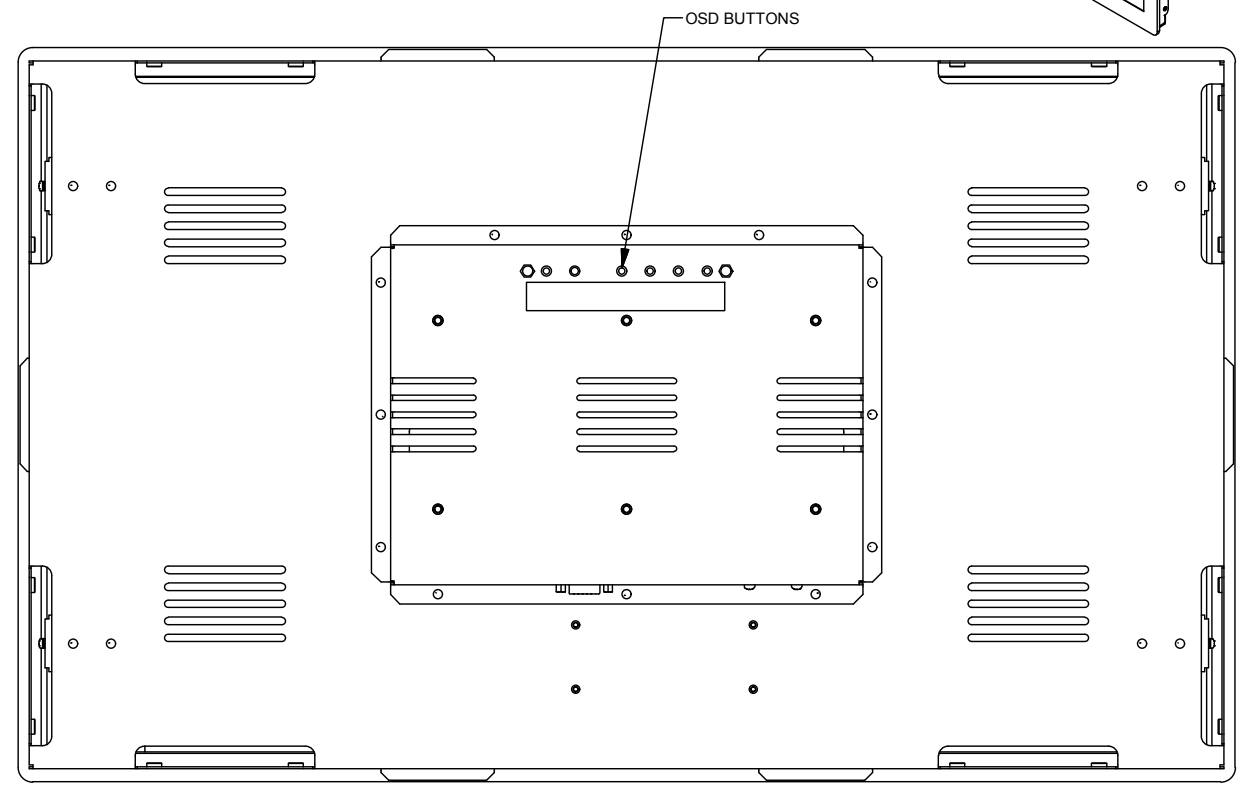
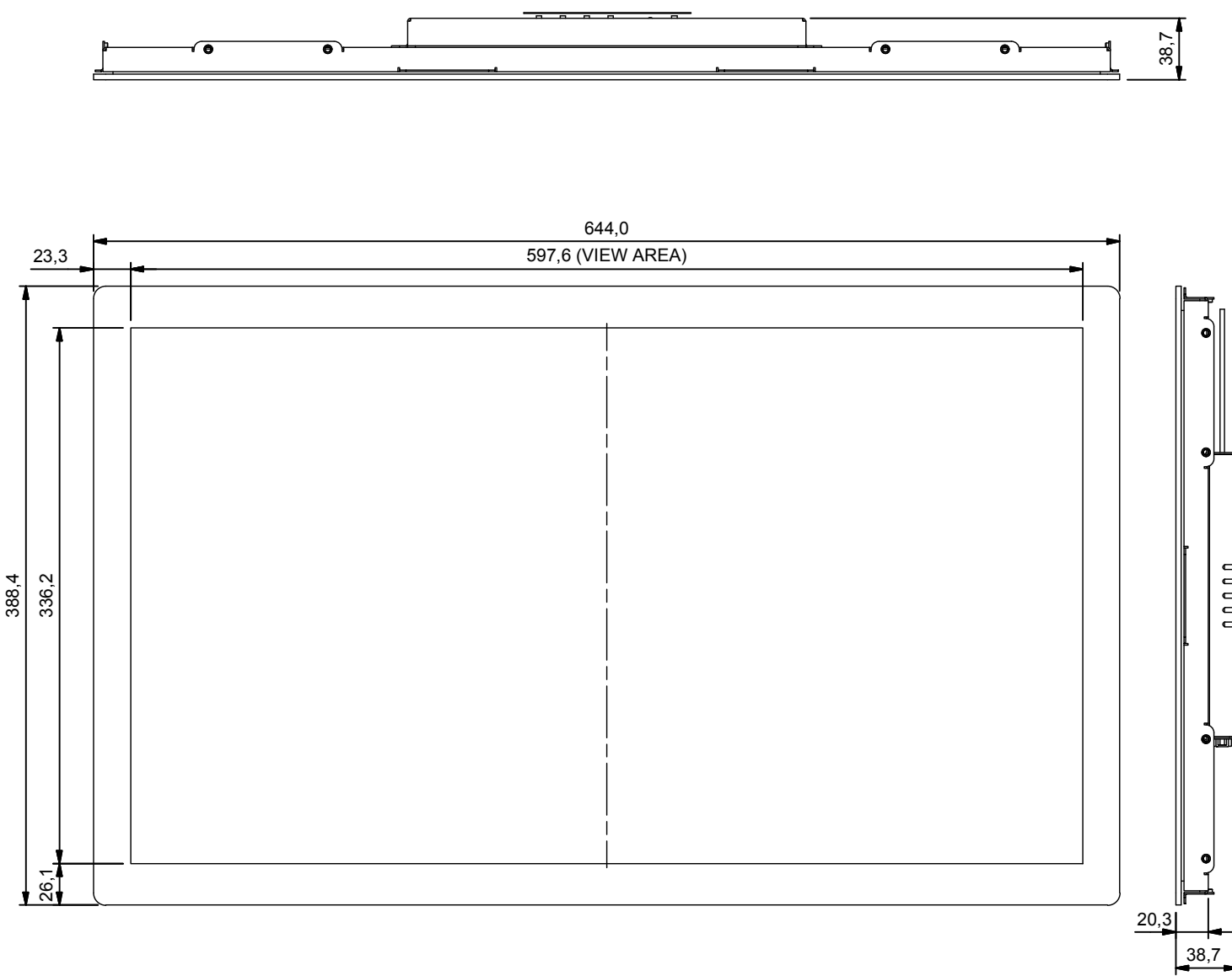
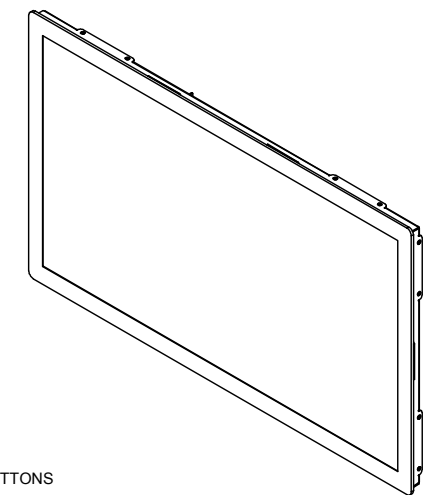

Suzo International (NL) BV
 Antonie van Leeuwenhoekstraat 9
 3261 LT Oud Beijerland
 Tel. +31 (0)186-643333
 Fax. +31 (0)186-643355
 E-mail info@suzo.com

RoHS Compliant 2011/65/EU

Description: 27" MONITOR PCAP	Date: 12-7-2017	Partnumber: 150TFTP2705	Revision: 00	Size: A3
----------------------------------	--------------------	----------------------------	-----------------	-------------