

Rev	AMEND	DATE	CHECK	APPR.
P1	Proto	2019.09.02	H.I.Woo	H.Y.Sohn
P2				
P3				

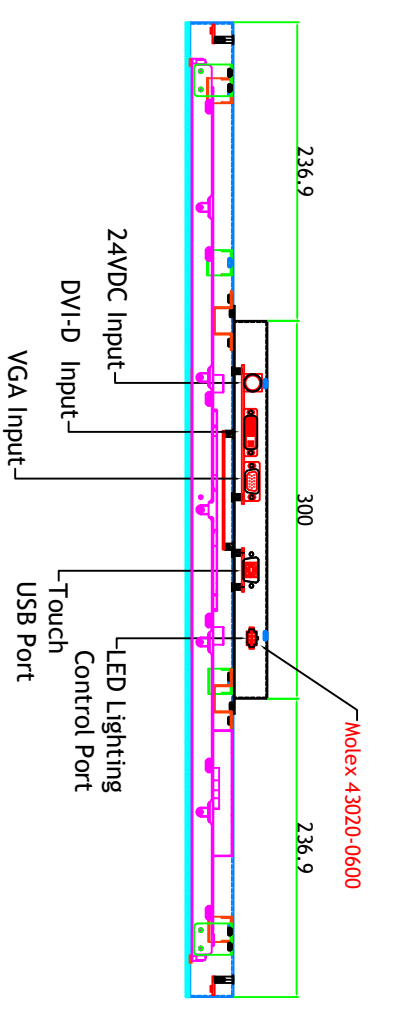

LED Lighting Control Port Pin Map (w/o IC)
 #1 : Red, #2 : Green, #3 : Blue
 #4 : VCC 12V, #5 : GND, #6 NC

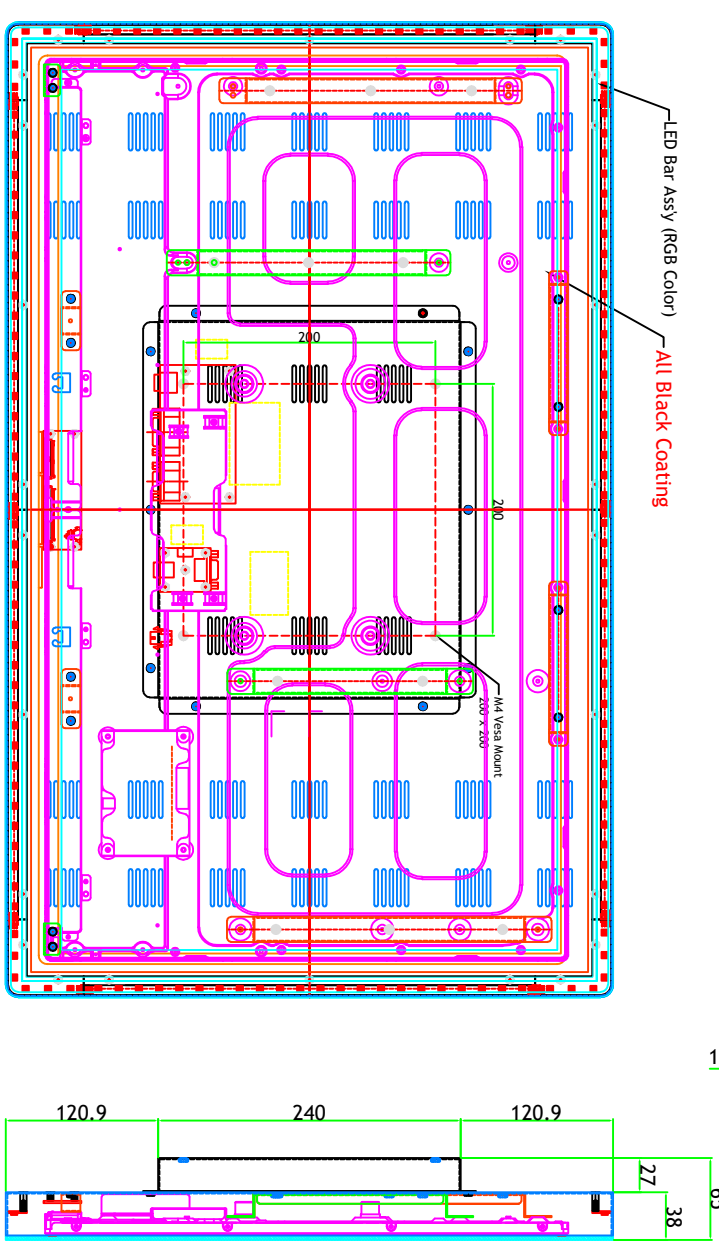
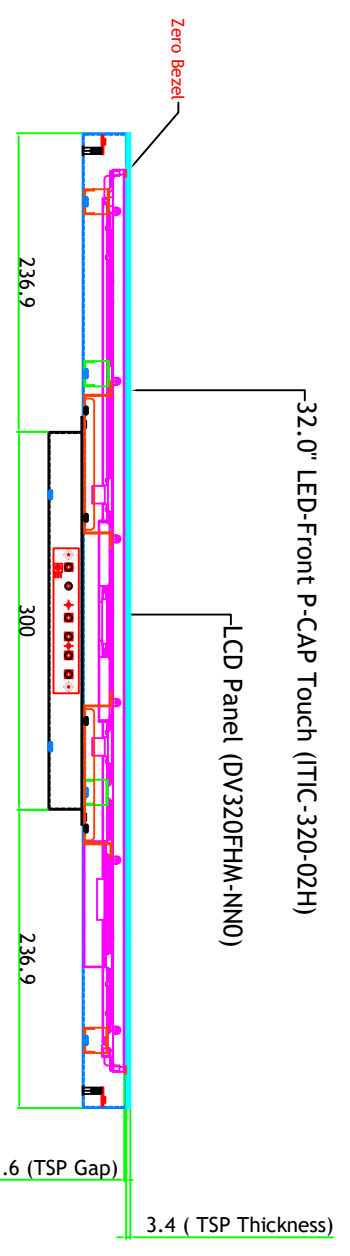
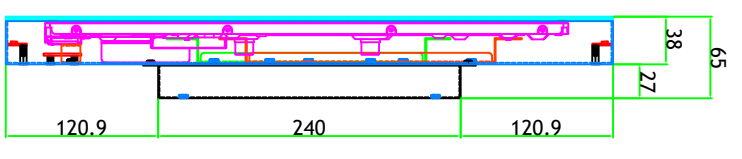
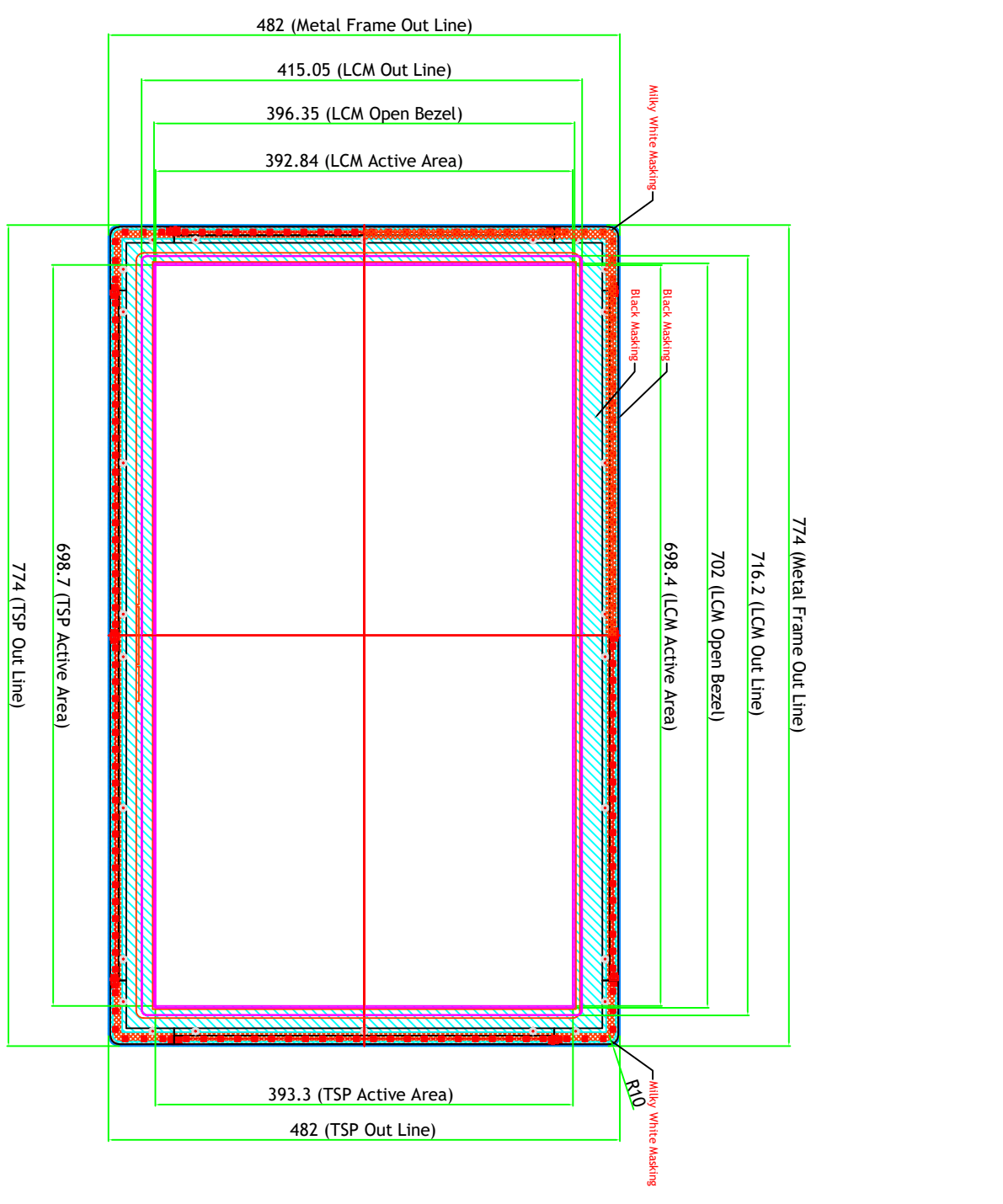
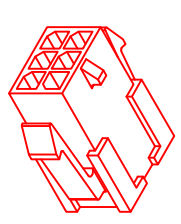
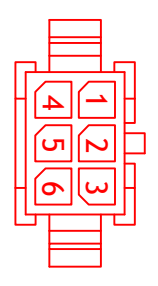

Molex 43020-0600

Main Frame GI = 1.2T Black Coating
 Rear Cover GI = 1.0T Black Coating

SUZOHAPP		MODEL NO	150LP3200	VIEW	UNIT : mm
NAME	32" Closed Frame	QTY	1	REV.	P1
DRAWN	CHECKED	APPROVED	DWG. NO	SCALE	DATE
H.I.Woo		H.Y.Sohn	4M3203043-00	1 / 1	2019.09.02
MATERIAL / FINISH		EGI T=1.2			

Rev	AMEND	DATE	CHECK	APPR.
P1	Proto	2019.09.02	H.I.Woo	H.Y.Sohn
P2				
P3				

Front View

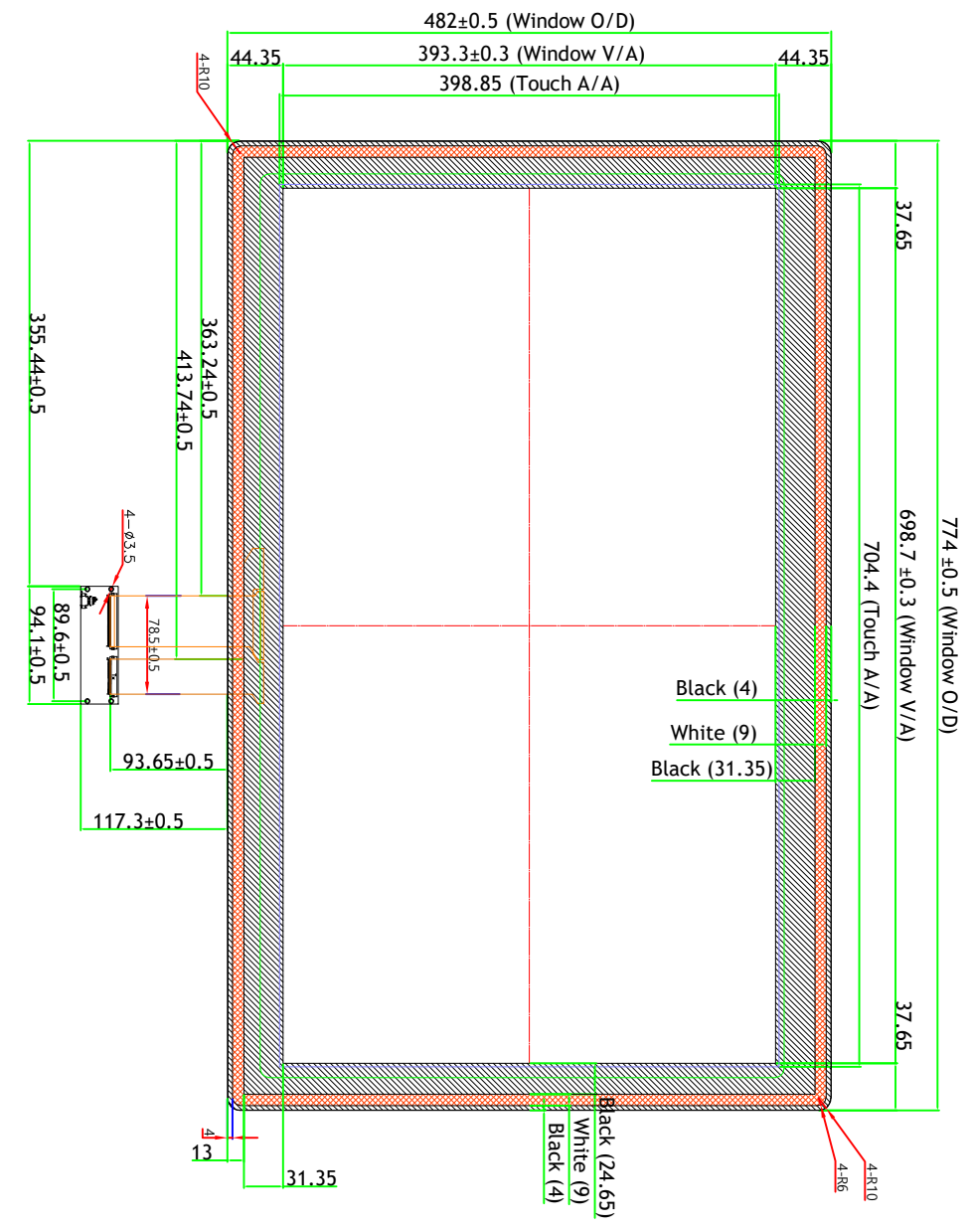

Rear View

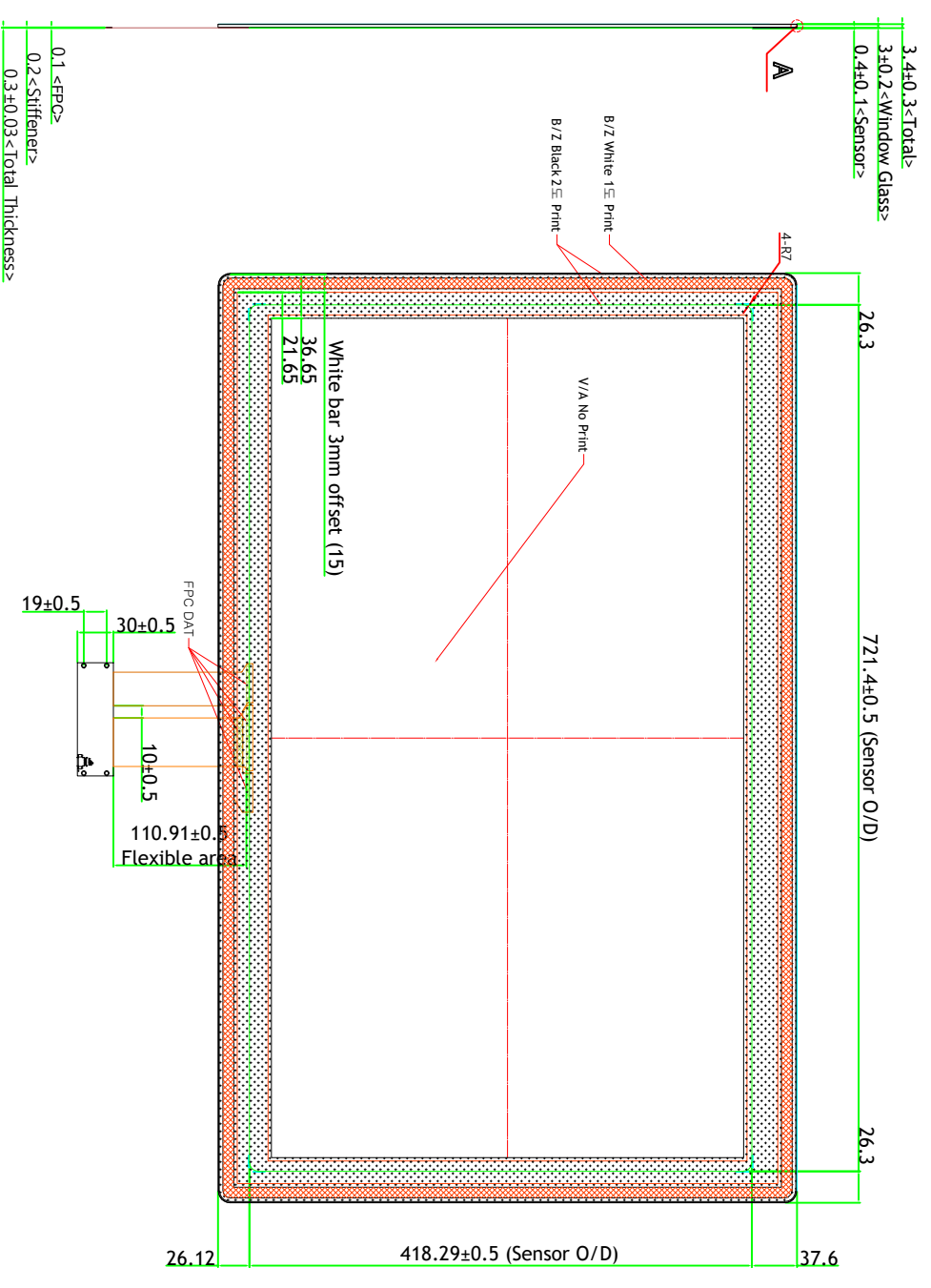

- Black Masking : 2 time
- Milky White : 1time
- Touch Align Masking : 1 time

32.0" LED-Front Lighting Model Touch Glass Drawing

NOTES

1. Type: GFF Capacitive Touch Panel
2. Cover Window: Tempered Soda Lime 3.0T
3. Touch Performance: 10 Point, 9 ϕ
4. Interface : USB
5. Window Decoration Color : Black Color Printing
6. Transmittance : 88% \pm 3%
7. Surface Hardness : More than 6H
8. Control Board : Silicon Works

Description	Material	Thickness
Cover Window	Tempered Soda Lime	3000 μ m
Top OCA	Optically Clear Adhesive	100 μ m
Top Film	ITO Film	100 μ m
Mid OCA	Optically Clear Adhesive	100 μ m
Bot Film	ITO Film	100 μ m

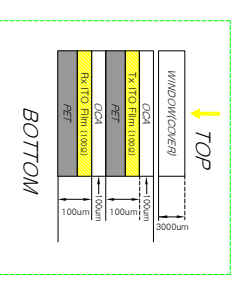

SUZOHAPP		MODEL NO	150LP3200	VIEW :	UNIT : mm
DRAWN	CHECKED	APPROVED	DWG. NO	QTY	REV.
H.I.Woo		H.Y.Sohn	4M3203043-00	1	P1
		MATERIAL / FINISH	EGI T=1.2	SCALE	1 / 1
				DATE	2019.09.02