

## Simplify Your Sourcing





# Table of Contents

About SUZOHAPP.....	4
Manufacturing Capabilities.....	6
R&D Capabilities.....	8

## DISPLAYS

VisionPro™ LCDs.....	13
VisionPro™ LED-Framed Monitors.....	14

## TOUCH DISPLAYS

Elo Open-Frame Touch Monitors.....	16
------------------------------------	----

## TOPPERS

SH1950 Video Topper.....	18
RGB Mini Topper, RGB Polygon Topper.....	19
RGB Tower Light Topper, Accessories.....	19
Dual-Sided LCDs.....	20

## PUSH BUTTONS

Dynamic Panel Systems.....	21
Chrome-Luminescent Pushbuttons.....	22
STC Pushbuttons.....	23
RGB Controllable Pushbuttons.....	23
RGB Controllable Pushbuttons.....	23
RGB Illuminated Pushbuttons.....	23
Concave Round Pushbuttons.....	24
BL Spinner.....	24
Square LED Pushbuttons.....	24
Jumbo White Pushbuttons with Black Trim.....	24
RGB LED, UFO Style.....	25
LCD Button Decks.....	25

## CASHLESS

UPT Card Reader.....	26
----------------------	----

## COIN VALIDATORS

Coin Entries.....	27
RM5 HD.....	28
RM5 Evolution.....	28
Coin Sorters.....	29

## HOPPERS

Cube Hopper.....	30
Flow Hopper.....	30
Evolution Hopper.....	31
Excel Hopper.....	31
ICS.....	32

## BILL VALIDATORS & RECYCLERS

MFL®.....	33
NV 200 Spectral.....	34
Spectral Payout.....	34
NV9 Spectral.....	35
NV22 Spectral.....	35
NV10 USB+.....	36
ICU.....	36
Bill-to-Bill 300™.....	37

## PRINTERS

Custom®.....	38
Nanoptix®.....	40
Slot Machines Tickets.....	42

## CABINET PARTS

Redemption Tickets and Dispensers.....	43
Door Switches, Cooling Fans.....	43
Barcode Scanners.....	44
PayConnect.....	46
Charge'N Play.....	47
Speakers, Power Supplies.....	48
Joysticks, Trackballs, Driving controls.....	49
LED Light Strips, Adhesive Led Strip Lighting.....	50
Lamps, Counters, Proximity Sensor.....	51

## LOCKS

E-PRL™.....	52
VENIA.....	54
Xlocks & STC.....	55
Security Bars.....	55
ASSA Desmo.....	56

## CUSTOMIZABLE CABINETS

Customizable Cabinets.....	57
----------------------------	----

## MECHANICAL DEVICES

Compact RGB Handle Mechanism.....	58
Custom Reel Mechanisms.....	58

## CHAIRS

Zenith, Carrillo, Apollo.....	60
-------------------------------	----

## ARCADE

Air Hockey, Basketballs, Mallets.....	61
---------------------------------------	----

## POOL CUES, BILLIARD ACCESSORIES

Cues.....	62
Chalk & Tips.....	64
Accessories.....	65
Table Lighting, Rules & Scoreboards.....	68
Refurb Accessories.....	69
Cloth Cutting.....	70

# SUZOHAPP

SUZOHAPP is a technology company with over 50,000 gaming, amusement, sports betting, lottery and bingo products for casino operators and gaming OEMs. Products include LCDs, sport betting solutions, toppers, hoppers, locks, coin/bill/reel mechanisms and buttons/decks. SUZOHAPP is also a leading software and hardware supplier of complete cash management solutions typically found anywhere from cashier cages to large-scale back office operations. SUZOHAPP is a global company with offices in 19 countries serving over 25,000 customers with regional delivery, local support and quick customization.



1,100+  
employees



50,000+  
products



35  
facilities



25,000  
customers



115  
Engineers



Hundreds  
of patents



## VISION

To be the global market leader in technology-driven cash management, self-service, and gaming devices through our commitment to people, customers, and quality



## MISSION

To provide our customers with excellent service and high-quality components, solutions, and software that create significant value for their business



## CORE VALUES



AGILITY



CUSTOMER  
FOCUS



INNOVATION



INTEGRITY



RELIABILITY



TEAMWORK

## PRODUCT BRANDS

SUZOHAPP is a diverse company with multiple brands and product lines

**SCAN COIN**

Cash**Complete**™

Comestero

Bill**4**Bill™

**currenza**

**coinCO**

**VisionPro**™

**CompetitionPro**

**BilliardPro**

**InteractivePro**

We take pride in our products, we take care of our customers and we value our people

# Global Reach

SUZHOP is a global company with a worldwide presence and a diverse workforce. SUZHOP has grown rapidly to meet the needs of the markets, expanding the breadth of its product offering and service capability. Its best-in-class product and service offerings create significant value and operational efficiencies for customers all over the world.

- International coverage through national subsidiaries
- Worldwide presence with a global service network
- Distribution partners all around the globe
- Variety of customers across multiple business segments



## Around The World & Around The Corner

In addition to the offices and manufacturing sites located on the map, SUZHOP has strategic partnership agreements with Value Added Distributors, Gaming Channel Partners, and Contract Service providers in those regions where market or license conditions dictate.

## Your Strategic Partner

SUZHOP's logistical support and supply chain configuration builds on its total value proposition by providing customers with cost saving delivery "From Our Door to Your Production Floor". Through continuous communication and feedback, the SUZHOP supply chain team works closely with customers and factories to maintain a steady product supply while eliminating costly additional inventory. We are firmly committed to providing the best customer service to all customers.



# Manufacturing Capabilities

## Adding Value Through Manufacturing

SUZOHAPP continually improves its engineering, manufacturing, service and distribution capabilities to meet the needs and exceed the expectations of its valued customers. With many years of industry experience and production excellence, SUZOHAPP has developed innovative customer-centric engineering and manufacturing processes.

SUZOHAPP designs and manufactures products that are used extensively in Gaming and Amusement devices as well as in demanding Industrial, Vending, and Transportation applications. In-house design, development and production resources located in multiple SUZOHAPP facilities, ensure that projects are efficiently taken from concept to completion.

## DESIGN & ENGINEERING



Design & Prototyping

### Equipment

- CAD workstations
  - Pro/Engineer
  - SolidWorks
  - AutoCAD
- FDM prototyping machine (3D printing technology)

### Capabilities

- Quick turn-around
- In-house prototyping

### Resources

- 30 Engineers
  - Electrical
  - Mechanical
  - Software

## LCD, TOPPERS & KIOSKS



LCD Production

### Equipment

- Integrated toppers
- OEM open frame
- LCD integration
- Signage & custom assemblies
- Bid specification & RFQ

### Capabilities

- 20,000 pieces per year

### Resources

- 3 Engineers

## PLASTIC INJECTION, TOOL & DIE



Direct Injection

### Equipment

- 5 - CNC mills
- 5 - Lathes and grinders
- 1 - Wire EDM
- 28 Injection machines

### Capabilities

- Sizes from 25-1,600 tons
- 20 million pieces per year
- 24-hour operation
- Insert & over-moulding
- Design to first shoot within 10 days
- 15 tools per month

### Resources

- 65 dedicated staff
- +35 flex staff

## PCB PRODUCTION



PCB Production

### Equipment

- SMT high speed mounter
- SMT inspection
- Wave solder

### Capabilities

- Surface mount
- Through-hole
- 150,000 boards per month

### Resources

- 25 dedicated staff
- +15 flex staff

## ASSEMBLY



Assembly

### Equipment

- 12 - Conveyor lines
- 30 - Workstation cells

### Capabilities

- 50 assemblies per hour, per line/cell
- Service and Repair
- Assemblies with up to 1,000 components

### Resources

- 100 dedicated staff
- +100 flex staff

## QUALITY ASSURANCE



Quality

### Highlights

- ISO 9001
- Testing services and capabilities

### Resources

- 30 FTEs in area of quality control and assurance

## Manufacturing and Distribution Facilities



### Manufacturing Site and Logistics Hub Poland

- Poznan, Poland
- 20,000 sqm
- 190 employees
- 400 product lines produced daily
- Coin validators, coin and bill recyclers, change machines, cash points for self-service laundrettes, car wash starter systems, cash management solutions



### Manufacturing Site China

- Zhuhai, China
- 12,000 sqm
- 250 employees
- Turnkey design / manufacture
- Interactive touch displays
- Transparent LCD technologies
- Cash handling technologies
- Printers, card/barcode readers, NFC/RFID, cameras
- Kiosks, loyalty and betting terminals
- Digital signage
- LED lighting and back lighting technologies



### Manufacturing and Distribution Site North America

- Mount Prospect, IL and Las Vegas, NV production locations
- Over 6,000 sqm
- Assembly, Distribution, Service and Support
- Cash Management Solutions: Note recyclers, coin recyclers, deposit safes
- Components & OEM: Joysticks, buttons, coin doors, LCDs, reel mechs, toppers, game controls

# R&D Capabilities

Investment in research and development is a top priority

Global product management teams meet continuously to develop new products and custom solutions for customers' ever-changing needs. Dedicated industrial, mechanical, and electrical engineering teams provide complete design, as well as component selection. SUZOHAPP utilizes contemporary modelling technology to produce accurate designs with competitive costs and short lead times.

## Technology Centres

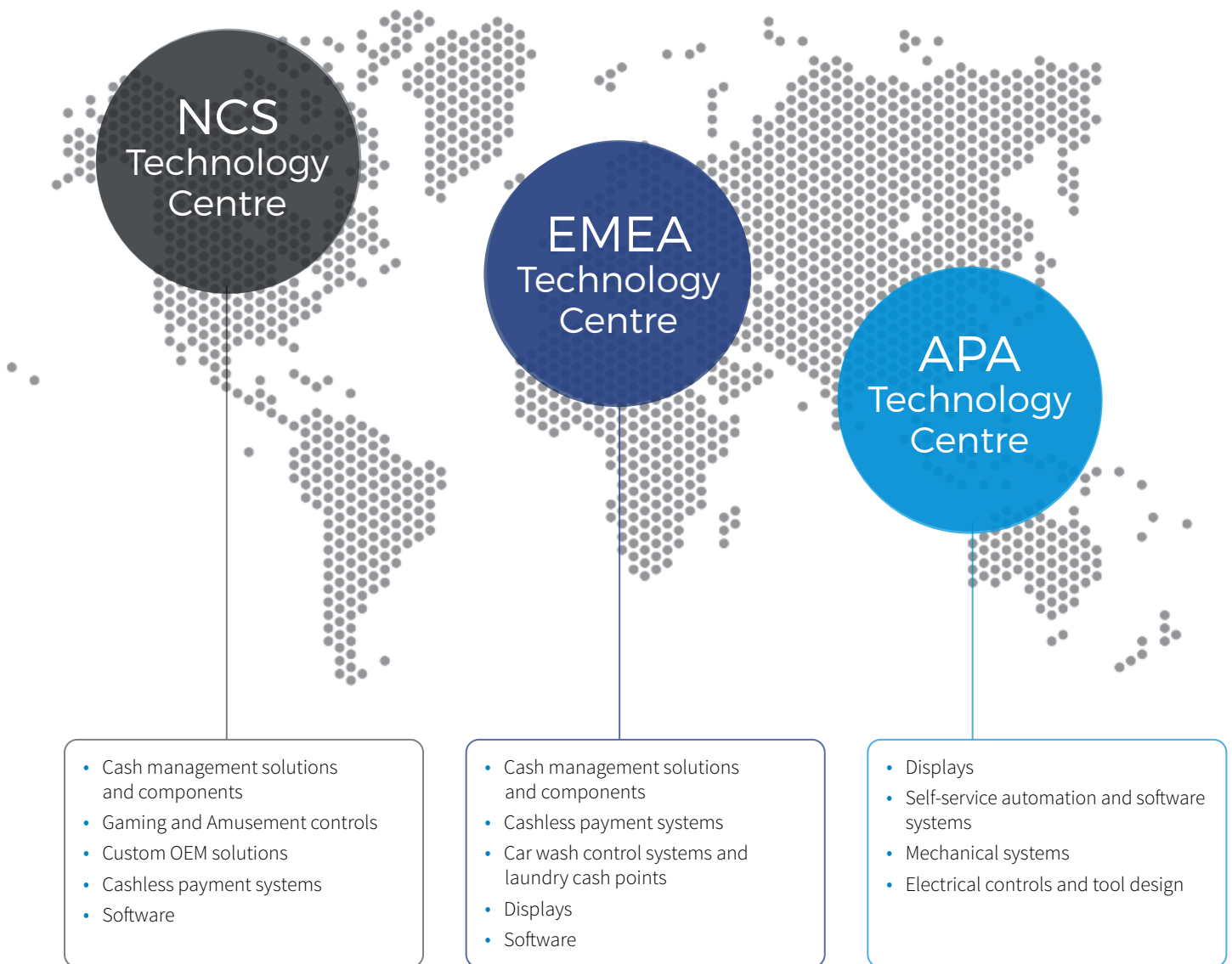

SUZOHAPP's Research & Development team is centralized into one global engineering centre of excellence, SUZOHAPP Technology Services (STS). This highly skilled department develops and supports the company's core technology, accelerates new product development and leads the introduction of innovative technologies.



## Design activities and expertise provided include:

- Turnkey design/manufacture of individual parts to complete machines - from concept development through final, highly engineered solutions
- 2D and 3D CAD Design – using SolidWorks for part/assembly modelling and drawings
- Metalwork/plastic design and electrical/wiring harnesses, virtual and physical prototyping, and product renderings
- Design of injection moulds and tooling
- Rapid prototyping through in-house 3D printing capabilities
- Proprietary electronics and PCB Design using the leading software package Altium
- Programming for microprocessors and Advanced Risk Machines (ARM, software development in most operating systems including Windows, Linux and Android OS
- Compliance testing and documentation, including UL

## Examples of some of the technologies SUZOHAPP works with:

- The latest LCD and touchscreen technologies, including projective capacitance
- LED lighting and back lighting technologies
- Embedded micro controllers and CPUs
- Electromechanical and mechanical systems

SUZOHAPP's dedicated team has been central to the success of many product deployments to the global amusement, gaming, industrial, transportation and vending markets.

## Projects have included:

- LCD retrofit integration
- Custom designed displays, including transparent LCD technology
- Interactive touch displays, large and small
- Cash handling technologies
- Printers, card/barcode readers, NFC/RFID, cameras
- Kiosks, loyalty and betting terminals
- Digital signage

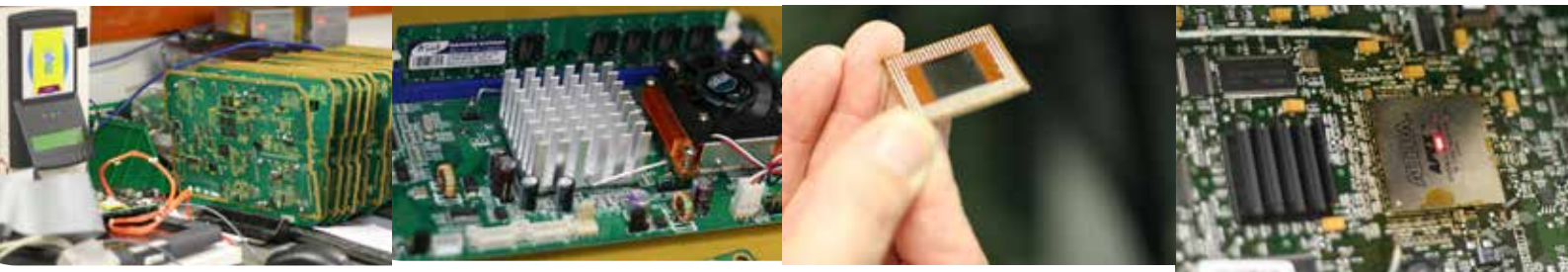

## Workshop Service

Highly experienced lab technicians can repair parts to component level, utilizing the latest diagnostic equipment and techniques. SUZOHAPP can also redesign, re-engineer, restore or re-manufacture parts and components reducing your business maintenance costs.

### Repair Services

- Electronic gaming machines
- Jackpot systems and player tracking hardware
- POS systems, ATMs, self-service terminals
- Cash handling – bill acceptors, coin mechanisms, hoppers
- Data scanners, PDAs, PC mainboards, logic boards
- LCD displays, touchscreens
- LCD and CRT monitors, power supplies
- Electronic assembly and manufacturing services
- Electronic kiosks
- Wagering terminals
- Other electro-mechanical assembly work

### SUZOHAPP technicians are highly skilled

- IPC certified specialist technicians ensure the highest quality in surface mount, hole through and wave soldering
- Experienced in repairing multilayer boards
- Ability to perform circuit programming (FPGA, JTAG) and program microprocessors (TQFP, SSOP, EPROM)

### SUZOHAPP technical experts:

- Re-work and re-flow BGA ICs
- Give logic boards, main boards and A-D boards a new lease on life
- Refurbish circuit boards for most popular gaming machines and electronic equipment
- Repair bill validators, ticket printers, hoppers and coin mechanisms, giving considerable savings compared to the cost of replacement

Simplify your sourcing  
with our broad product range,  
local resources, and global capability





SUZOHAPP



# High Quality LCDs for Gaming, Amusement, Sports Betting, Lottery, and Bingo

OEM Touch and Non-Touch



VisionPro™ is SUZOHAPP's premium line of LCDs using top panel brands and high-quality boards. Fast customization is available for both OEMs and upgrades: 6.2" to 90", specialized panels and integration, customized metal, touchscreens and inputs.

## Features:

- ✓ Standard sizes from 15" to 43"
- ✓ Choice of
  - 10+ touch Projected Capacitive (PCAP), true-flat, seamless edge-to-edge glass
  - 3M Surface Capacitive (SCAP) touch technology
  - Protective Glass
- ✓ Standard and wide viewing angle units available
- ✓ Common footprint for touch and non-touch variations
- ✓ DVI and VGA, HDMI and DisplayPort available
- ✓ LED options for surrounding display
- ✓ Economically priced
- ✓ 1-year standard warranty

Model	Size/Aspect ratio	Resolution	Viewing angle	Panel Brightness	Contrast	Touch/Glass
49-1902-DA	19" 5:4	1280x1024	178° x178°	250 cd/m <sup>2</sup>	1000:1	Optional I/R USB or serial
150TFTx2157	21.5" 16:9	FHD	170° x160°	250 cd/m <sup>2</sup>	1000:1	3M touch or tempered glass
150TFTG2153	21.5" 16:9	FHD	178° x178°	250 cd/m <sup>2</sup>	1000:1	Black edge-to-edge tempered glass
49-3306-02	21.5" 16:9	FHD	178° x178°	250 cd/m <sup>2</sup>	1000:1	3M USB or serial
150TFTx2206Mxx	22.0" 16:10	1680x1050	178° x178°	250 cd/m <sup>2</sup>	2000:1	3M touch or tempered glass
150TFTx2382	23.8" 16:9	FHD	178° x178°	250 cd/m <sup>2</sup>	1000:1	PCAP and matching glass version
150TFTx2306xxx	23.0" 16:9	FHD	178° x178°	250 cd/m <sup>2</sup>	1000:1	3M touch or tempered glass
150TFTS2414Mxx	24.0" 16:10	1920x1200	178° x178°	300 cd/m <sup>2</sup>	1000:1	3M USB or serial
150TFTx2411xxx	24.0" 16:10	1920x1200	178° x178°	300 cd/m <sup>2</sup>	1000:1	3M touch or tempered glass
150TFTx2705X	27.0" 16:9	FHD	178° x178°	300 cd/m <sup>2</sup>	3000:1	PCAP and matching glass version

and many more, see [suzohapp.com/monitors](http://suzohapp.com/monitors)





# LED-Framed Monitors LCDs Accented with a Frame of Color!

A Range of Sizes, Touch and Non-Touch,

Addressable or RGB LEDs, in Three Designs



## CHOICES

1 Size	 21.5"	 23.8"	 27"	 32"	 43"
2 Design	<ul style="list-style-type: none"> <li>• <b>Halo</b> illumination surrounding the display, external VESA mount</li> </ul>		<ul style="list-style-type: none"> <li>• <b>Edge</b> and front illumination external VESA mount</li> </ul>		<ul style="list-style-type: none"> <li>• <b>Front</b> illumination for flush integration within a cabinet</li> </ul>
3 LEDs	<ul style="list-style-type: none"> <li>• <b>RGB</b> solid color, 12V without IC</li> </ul>		<ul style="list-style-type: none"> <li>• <b>Addressable</b> individually driven, 5V with IC</li> </ul>		
4 Touch or Non-Touch	<ul style="list-style-type: none"> <li>• <b>10-touch PCAP</b> (Projected Capacitive technology) <b>behind 3mm tempered glass</b></li> </ul>		<ul style="list-style-type: none"> <li>• <b>Non-touch 3mm tempered painted glass</b></li> </ul>		

## FEATURES

- ✓ Rigid high-quality PCB-mounted LEDs, no adhesive strips, no hotspots, no dark corners
- ✓ True-flat, black closed-frame designs
- ✓ 21.5"/ 23.8": 250 cd/m<sup>2</sup>, 1000:1  
27": 300 cd/m<sup>2</sup>, 3000:1  
32": 400 cd/m<sup>2</sup>, 1200:1  
32" (P): 500cd/m<sup>2</sup>, 3000:1  
43": 450 cd/m<sup>2</sup>, 1100:1  
43" 4K UHD: 500 cd/m<sup>2</sup>, 4000:1
- ✓ FHD 1920x1080, WVA 178°x 178° for landscape or portrait usage (43" 4K UHD 3840x2160)
- ✓ 10-touch PCAP for Windows 7 or later, Linux 4.4 or later
- ✓ Dual-line LEDs in Addressable versions
- ✓ VGA + DVI standard, HDMI and DisplayPort available (4K UHD: HDMI/DP only)
- ✓ 12VDC (24VDC for 32", 43"), optional 100-240V AC brick
- ✓ Operating temperature: 0-50 °C (32-122° F)
- ✓ FCC, CE, RoHS
- ✓ Drawings and CAD files available on request
- ✓ Customization possible

2 Design



Halo Design

For floating monitor outside your cabinet. Surround color in front, side, rear for a halo effect.



Edge Design

For front and edge illumination, external use.



Front Design

For mounting monitor flush inside your cabinet.

CHOOSE FROM OVER 50 VARIATIONS!

1 Size	2 Design	3 LEDs	Max Dimensions (WxHxD)	Part Number	
				4 Touch	4 Non-Touch
21.5"	Front	RGB	542 x 336.6 x 51.0 mm (21.3" x 13.3" x 2.0")	150LP2150	150LG2150
		Addressable		150LP2152	150LG2152
	Edge	RGB	542 x 336.6 x 53.3 mm (21.3" x 13.3" x 2.1")	150DLP2155	150DLG2155
		Addressable		150DLP2156	150DLG2156
	Halo	RGB	562.6 x 357.2 x 56.0 mm (22.1" x 14.1" x 2.2")	150DLP2151	150DLG2150
		Addressable		150DLP2150	150DLG2150
23.8"	Front	RGB	588 x 367 x 51.0 mm (23.1" x 14.4" x 2.0")	150LP2380	150LG2380
		Addressable		150LP2382	150LG2382
	Edge	RGB	588 x 367 x 53.3 mm (23.1" x 14.4" x 2.1")	150DLP2385	150DLG2385
		Addressable		150DLP2386	150DLG2386
	Halo	RGB	608.6 x 387.6 x 56.0 mm (24" x 15.3" x 2.2")	150DLP2381	150DLG2381
		Addressable		150DLP2380	150DLG2380
27"	Front	RGB	660 x 407 x 51.0 mm (26" x 16" x 2.0")	150LP2700	150LG2700
		Addressable		150LP2702	150LG2702
	Edge	RGB	660 x 407 x 53.3 mm (26.0" x 16.0" x 2.1")	150DLP2705	150DLG2705
		Addressable		150DLP2706	150DLG2706
	Halo	RGB	680.6 x 427.6 x 56.0 mm (26.8" x 16.8" x 2.2")	150DLP2701	150DLG2701
		Addressable		150DLP2700	150DLG2700
32"	Front	RGB	773.8 x 481.8 x 59.8mm (30.5" x 19.0" x 2.4")	150LP3200	150LG3200
		Addressable		150LP3202	150LG3202
	Edge	RGB	774 x 482 x 65.0 mm (30.5" x 19.0" x 2.4")	150DLP3205	150DLG3205
		Addressable		150DLP3206(P)	150DLG3206
43"	Front	RGB	1040.0 x 630.0 x 67.0mm (40.9" x 24.8" x 2.6")	150LP4300	150LG4300
		Addressable		150LP4302	150LG4302
	Edge	RGB	1040 x 630 x 67.0 mm (40.9" x 24.8" x 2.6")	150DLP4305	150DLG4305
		Addressable		150DLP4306	150DLG4306
43" 4K UHD	Edge	RGB	1040.0 x 630.0 x 67.0mm (40.9" x 24.8" x 2.6")	150DLP4345	-
		Addressable		150DLP4346	-

## Elo Touch Solutions Open Frame Gaming Monitors



### Brilliant Display. Superior Quality. Competitive Price.

Engineered and designed specifically for the demanding requirements of the gaming industry, the 90-Series open-frame displays feature touch technology built-in rather than glued-on. Elo is the world leader in commercial touch with over 20 million installations, half a million units per year, nearly 2,000 units per day.

Select from a wide range of sizes from 10" to 27" to fit in any gaming environment. Other Elo products extend the range to 70".

Only Elo produces the touchscreens, controllers, drivers, and monitor for a complete solution proven in 10,000s of gaming installations.

### Take advantage of these great features:

- ✓ Next generation Projected Capacitive (PCAP) 2GS technology (2 glass solution)
- ✓ Highest optical quality and longevity as no plastic films, no metal mesh
- ✓ 10-touch true-flat solution
- ✓ Thru-glass mode which operates through up to 6 mm customer-supplied glass
- ✓ Common mechanical and electrical components across the line for easy design-in, compliance testing, service, and transition between sizes
- ✓ HDMI, DisplayPort, VGA inputs, with common port design across all units
- ✓ Built-in watertight edge seal
- ✓ Magnetic tethered OSD control box
- ✓ Unique field-replaceable touchscreen glass design
- ✓ Global agency approvals: United States UL, FCC; Europe CE TÜV; Australia RCM; Canada cUL, IC; China CCC; Japan VCCI; Korea KCC; Mexico CoC; Taiwan BSMI; International CB; RoHS
- ✓ Passes UL and IK07 Ball Drop tests
- ✓ 50,000 hour demonstrated MTBF
- ✓ 3-year standard global warranty



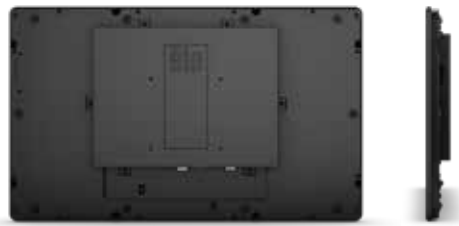

New sleek finished enclosure

Model	Diagonal size	Aspect ratio	Contrast ratio	Brightness (panel)	Viewing angle	Native resolution
1093L	10.1"	16:10	800:1	350 nits	85°/85° or 170°/170°	1280 x 800 at 60Hz
1291L	12.1"	4:3	1500:1	450 nits	89°/89° or 178°/178°	800 X 600 at 60Hz
1590L	15"	4:3	800:1	300 nits	80°/70°- 80° or 160°/150°	1024 X 768 at 60Hz
1593L	15.6"	16:9	500:1	300 nits	80°/80° or 160°/160°	1366 x 768 at 60Hz
1790L	17"	5:4	1000:1	250 nits	85 °/80° or 170°/160°	1280 x 1024 at 60Hz
1990L	19"	5:4	1000:1	250 nits	85°/80° or 170°/160°	1280 x 1024 at 60Hz
1991L	19"	5:4	1000:1	250 nits	89°/89° or 178°/178°	1280 x 1024 at 60Hz
2094L	19.5"	16:9	3000:1	250 nits	89°/89° or 178°/178°	1920 x 1080 at 50, 60Hz
2293L	21.5"	16:9	1000:1	250 nits	85°/80° or 170°/160°	1920 x 1080 at 50, 60Hz
2294L	21.5"	16:9	1000:1	250 nits	89°/89° or 178°/178	1920 x 1080 at 50, 60Hz
2494L	23.8"	16:9	3000:1	250 nits	89°/89° or 178°/178	1920 x 1080 at 50, 60Hz
2794L	27"	16:9	3000:1	300 nits	89°/89° or 178°/178	1920 x 1080 at 50, 60Hz

## 10" to 27" desktop touchmonitors, All-in-Ones and interactive digital signage from 10" to 70"

SUZOHAPP also distributes the complete line of Elo Touch Solution products — seen in cashier cages, sports betting outlets, and on the gaming floors in top casinos around the world. Monitors and All-in-Ones for front/back office, interactive digital signage, bingo, lottery, sports betting, player tracking, loyalty systems and POS.



# SH1950 Video Topper

## 19.5" high viewing angle panel with LED back light

The SH1950 Video Topper consists of a 19.5" wide viewing angle panel with LED back light, VGA or DVI cable out, 12V input and can be equipped with a black or chrome bezel. The sides have RGB illumination covered by an acrylic front plate. The SH1950 Video Topper and Edge Lit Topper are manufactured in SUZOHAPP China, in accordance to the highest standards. Final assembly, as well as customizations are done at a regional production facility.

The SH1950 Video Topper is a great addition to every cabinet!



19.5" high viewing angle panel with LED back light (optional without LCD to be used as a light box)

## RGB Mini Topper



- ✓ Whole unit operates on a safe 12Vdc
- ✓ Different attract modes in a program such as twinkling, full on, rotating left to right and right to left, filling rotation etc
- ✓ Standard supplied with 32 bright white LEDs (7 different light brightness selections on the topper control board)
- ✓ Standard supplied with bright chrome bezel
- ✓ Mounting location and through holes for tower lights in the top of the body
- ✓ Flat, angled or radius base options for different cabinet configurations, easy mounting with two threaded studs
- ✓ Metal mounting bracket available for mounting on existing tower light fitting holes, to be used in conjunction with mounting bracket

## RGB Polygon Topper



- ✓ Completely backlit thanks to bright white LEDs
- ✓ Includes tower light with color foils
- ✓ On board PCB allows stand-alone operation or synchronization of up to eight topper boxes
- ✓ Seven pre-programmed flashing patterns
- ✓ Different attract modes including full on, rotating left to right and right to left, flashing and more
- ✓ Optional mounting base available
- ✓ Artwork not included

## RGB Tower Light Topper



- ✓ Designed to be mounted on top of any standard round classic tower light
- ✓ Great for advertising special machine features such as Multi-Denomination, Ticket-In Ticket-Out, Hot New Game, Server Based Gaming, etc.
- ✓ Translucent bezel with 20 ultra bright Nichia multi-color
- ✓ RGB LED's provide light output for a elegant multi-colored lightshow
- ✓ Pre-programmed with 8 unique flashing patterns and 7 different color combinations
- ✓ Several optional base/cap adapters make it easy to use on other styles of tower lights

## Accessories



Ballast



Mounting base - flat



Synchronizer



Compact fluorescent lamp



Power supply



RGB LED light strips



Mounting base - 15° Slant angle



LED light strip controller

# Dual-Sided LCDs

## Interior Signage

Perfect for casinos, table games, signage or other interior environments

With its stylish design the Dual-Sided LCDs displays are a slick way to share content, catching customers coming and going. Available in three distinct sizes to insure the perfect fit for your venue. The low power requirements allow the display to stand out just about anywhere. To eliminate dual graphic and multiple PC issues both displays are driven by a single HDMI signal source.



1 M<sup>†</sup> round pole with black bezel with added gold\* edge featured

\*Different outer and inner colors available upon request but MOQ's apply.

†Custom pole length and base mounting options available upon request but MOQ's apply.

### Technical Specifications

Screen Diagonal	21.5"	23"	27"
Orientation	Landscape	Portrait	Landscape
Resolution	FHD 1920 x 1080	FHD 1920 x 1080	FHD 1920 x 1080
White Luminance	250 cd/m2	250 cd/m2	250 cd/m2
Contrast Ratio	3000:1	1000:1	1000:1
Operating Temperature	0 ÷ 50 °C	0 ÷ 50 °C	0 ÷ 50 °C
Viewing Angle	89° all sides	89° all sides	89° all sides
Power Requirements	12vDC	12vDC	12vDC
Display Height	Custom <sup>†</sup>	Custom <sup>†</sup>	Custom <sup>†</sup>

# Dynamic Panel Systems

SUZOHAPP's Dynamic Panel Systems (DPS) feature the latest innovation in pushbuttons - all the adaptability of touchscreens with the tactile satisfaction of mechanical pushbuttons. We remove the limits of standard LCD pushbuttons in both shape and content, utilizing a single LCD with a unique fiber optic conduit to elevate the image to the surface of the injection molded plastic lens cap. Easily program the entire deck at once with dynamic and configurable content allowing for unprecedented interaction between games and buttons as well as ease of transition between content.



Self-labeling buttons without the complexity or cost

Touchscreen flexibility, with familiar tactile feel

Optional illuminated RGB bezel

Confidence and speed of a physical button

Excellent visibility without glare or distortion

Interfaces: VGA, DVI-D or LVDS

Button interface is available in RS232 or USB

DisplayPort and HDMI are available upon request

## Advantages

- ✓ Incredibly flexible – the display panel and buttons can be virtually any size to fit your cabinet and the buttons can be manufactured in any shape
- ✓ Innovative use of precision image transfer fiber optics
- ✓ Traditional tactile pushbutton feel
- ✓ Display graphics, text, animations, video, and even highlight error states with moving color
- ✓ Add versatility and intrigue to games to attract attention

# LCD Pushbuttons

The LCD Button unit is an innovative addition to the SUZOHAPP range for gaming devices, giving the game designer the additional tools to enhance the content and player of new gaming machine concepts.



LCD is integrated into the button and moves with lens cap

Light ring comes in a range of colors

Option to customize LCD decal surround (black standard)

24 frames per second animation

Full color 128 x 128 pixels

USB interface, controller board controls up to 16 buttons

# Chrome-Luminescent Pushbuttons

Polished chrome-plated button bezel with translucent color washer molded in bezel to provide edge luminescent effect. Available in several color combinations of button & luminescent effect. Additional customization also available.



Locking nut has special design to allow it to fit over “Snap-Tab” feature with microswitch installed

Ease & flexibility of mounting to metal control panels using either the “Snap-Tab” or traditional locking nut

Switch pre-assembled on button for reduced assembly time into control panel

Subminiature microswitch provides additional clearance room under control panel

Grounded for ESD protection

Polycarbonate lens for optical clarity and durability

Switch snaps on bezel of button eliminating the need to have separate lamp holder

**RBM-730S-SCL**  
 Size Color Luminescent  
 Color, Bezel

**S = Size**

**C = Lens Colour**

**L = Luminescent Effect**

A = Large Square	2 = Red	2 = Red
B = Small Square	3 = Amber (Orange)	3 = Amber (Orange)
C = Large Rectangle	4 = Yellow	4 = Yellow
D = Small Rectangle	5 = Green	5 = Green
E = Large Round	6 = Blue	6 = Blue
F = Small Round	9 = White	9 = White

Nut Sold Separately, Part number RBM-K730-001

# STC Pushbuttons

STC Pushbuttons with Subminiature Microswitch designed to retrofit all existing VLT/Poker buttons which use a 22 mm square mounting hole. Available in 6 different colors: red, orange, yellow, green, blue or white.



Designed to resist spills and sticking, for high reliability and long life, tested for 10 million+ cycles

Standard supplied with spacer bezel for mounting on top or in the panel (low-profile)

Small size, low profile, provides maximum player comfort

Full 0.5 mm thickness on lamp terminals holds lamp or LED connectors securely

For use with 5 mm wedge base lamps or LEDs (not included)

Standard fitted with Cherry DB5 style microswitch with 2.8 mm terminals for easy connection

# RGB Controllable Pushbuttons

## Features

- ✓ Built-in RGB LED PCB - it can be controlled by LED driver with constant current output
- ✓ Built-in microswitch
- ✓ Made with highest quality raw materials
- ✓ Suitable to be used for various machines
- ✓ Over 10 million times reliability test for microswitch with gilded contact legs
- ✓ Connection options: 6pin connector, 110" terminal

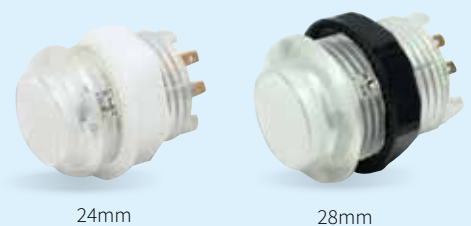

24mm

28mm

# RGB Illuminated Pushbuttons

## Features

- ✓ 13 different display modes
- ✓ Top quality with a competitive price
- ✓ Magnificent lighting effects
- ✓ Simple installation
- ✓ Available in different colours



RGB Illuminated Pushbutton (Large)

RGB Illuminated Pushbutton (Small)

RGB Illuminated Pushbutton (Medium1)

RGB Illuminated Pushbutton (Medium2)

# Concave Round Pushbuttons

## Features

- ✓ Special anti-scratch material - with stunning flashing vehicle baking finish appearance
- ✓ Built-in microswitch
- ✓ Top quality with a competitive price
- ✓ Suitable to be used for various machines



# BL Spinner

## Features

- ✓ Whole metal structure - High durability
- ✓ Moisture-proof plastic cover design
- ✓ Built-in automatic RGB LED lighting effect
- ✓ Made with highest quality raw materials
- ✓ Suitable to be used for various machines



# Square LED Pushbuttons

## Features

- ✓ Two colour design - Unique and very attractive appearance
- ✓ Built-in lighting LED design with 110 terminals
- ✓ Built-in microswitch
- ✓ Suitable to be used for various machines
- ✓ Over 10 million times reliability test for microswitch with gilded contact legs





# Jumbo White Pushbuttons with Black Trim. RGB LED, UFO Style

## Features

- ✓ Achieves magnificent lighting effects
- ✓ 13 different display modes to control.  
Enhance user interaction for your machine
- ✓ Top quality with a competitive price
- ✓ Simple installation takes your machine assembly to the next level
- ✓ Available in different colors



## LCD Button Decks

### 15" 1/3 LCD Button Deck

- ✓ 10-point PCAP
- ✓ 170°/160° viewing angle
- ✓ 2T glass
- ✓ Black masking
- ✓ R5 corners
- ✓ USB



### 16.4" LCD Button Deck

- ✓ 170°/160° viewing angle
- ✓ 10-point PCAP
- ✓ 2T glass
- ✓ Black masking
- ✓ USB



### 16.4" LCD Button Deck with customized glass

- ✓ 170°/160° viewing angle
- ✓ 10-point PCAP
- ✓ 2T glass
- ✓ Black masking
- ✓ USB
- ✓ 1 push button hole

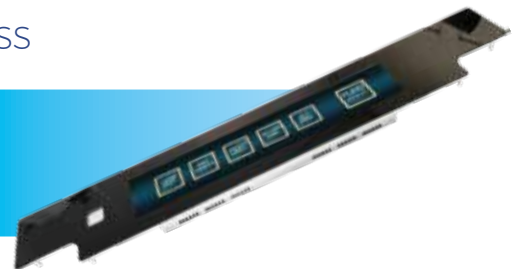

# UPT Card Readers

## All-In-One Solutions For Digital, EMV Contact and Contactless Payments

The UPT Card Readers are certified, 4G Ready, and feature beautiful large full-color touch screens, providing an attractive interface with ultimate payment flexibility for your customers. The UPT Card Readers can even accept and integrate with campus card systems in addition to digital, EMV contact and contactless payment cards. Built-in 4G telemeters report machine health data to management systems.

NEW



UPT-B Card Reader  
With Bill Validator Bezel



UPT-F Card Reader



Certified



4G Ready



Large Full-Color  
Touch Screens



# Coin Entries

For application on flat surfaces and with various inclinations

Devices in different colors and sizes. Some models are equipped with lighting to attract more attention.



Standard coin entry for flat surfaces. Available in chrome or gold finish, with coin reject lever



Adjoining coin entry for flat surfaces. Available in chrome or gold, with coin reject lever



Coin entry for flat surfaces. Available in black ABS, with coin reject button, in the lengths of 7-20-30 and 45 mm



Top coin entry for flat surfaces. Available in chrome plated steel, with coin reject button



Coin entry for surfaces with a 30° inclination. Available in chrome or gold finish, with coin reject button



Coin entry for surfaces with a 30° inclination. Available in black, chrome or gold finish, with a coin reject button and in lengths of 42.5 – 62.8 mm



Coin entry for surfaces with a 30° inclination. Made of die-cast material with a coin reject button and in lengths of 42.5 – 62.8 mm



Standard coin entry for inclined surfaces. Solid and robust, it is made of chrome plated steel, with coin reject button. It accepts coins up to 3 mm thick



Cast metal coin entry for surfaces with a 15° inclination. Characterized by its sharp lines and catchy design



Coin entry for surfaces with a 30° inclination. It is available in chrome plated steel, with a coin reject button and luminous "COIN" inscription

## RM5 HD

### Extreme reliability, remarkable acceptance speed and high versatility

The RM5 HD coin validator has set new reference standards in coin validation. Through 5 different sensors and 10 recognition parameters, it ensures a high level of recognition and discrimination of valid and counterfeit coins with an unprecedented speed of up to 6 coins per second.

HD high-discrimination system based on 10 different parameters regarding frequency, dimensions and phase

5-sensor identification technology: 3 inductive sensors, 1 optical sensor and 1 magnetic sensor

USB version also available



Advanced electronic and mechanical anti-fraud system: electronic anti-fishing device, coin movement direction detection, 3 mechanical traps, and wire cutting blade

Tropicalised version also available for environments affected by adverse weather conditions

over 2 million of Comestero coin mechanisms installed!

## RM5 Evolution

### The record-breaking coin validator

The RM5 Evolution coin validator is well known for its quality and reliability. Its electronics combines extraordinary selectivity with extreme programming versatility: the Cloning system allows the transfer of the configuration parameters.

3 pairs of inductive sensors for processing 6 different parameters regarding the material and the mass

3 pairs of optical sensors for determining the coin's diameter

Identification channels: up to 59, each of which can be redirected to the outlets. The first 6 support Self-Prog mode



A mechanical and electronic anti-fishing device

Serial interface for external connections (portable programmer or PC)

Credit recognition: parallel, binary, pulse

## Coin Sorters

### CINCO

Coin sorter with 5 sorting paths plus reject mechanism specifically designed to satisfy the requirements of any type of gaming machine. It can be installed both on machines operating in ccTalk and in parallel, allowing switching modes with ease.



### SPS41LCC4

Coin sorter with 4 in-line sorting paths and reject placed over the third sorting outlet.

### SPS31LCC3

Coin sorter with 3 in-line sorting paths and reject placed over the third sorting outlet.



### SPS31SCC3

Coin sorter with 3 in-line sorting paths and reject placed over the last sorting outlet.

### SPS300CC3/VER-B

Coin sorter with 3 in-line sorting paths and a bottom reject mechanism.



### SPS300CC3

Coin sorter with 3 in-line sorting ways and front reject.

# Cube Hopper

## High speed single denomination hopper

The Cube Hopper has an expandable hopper capacity and is made from extremely strong, wear-resistant plastics. With one configuration it covers different coin sizes, and in case of conversion the disc can be replaced in seconds to convert the denomination of the hopper. The hopper is square and easy to mount by means of standard mounting bracket. By using an unique “Sun & Planet” gearbox system, this hopper offers the possibility to contain and count (with two extensions) over 1,200 coins of ø 24 mm. The hopper is protected by an auto-reverse anti-jam system and has an indirect optical readout with a continuous monitored optic sensor control. A low-level detection is integrated in the coin cup. A Dual Hopper version is also available which can payout two different types of coins.



# Flow Hopper

## Innovative through-hole hopper

The innovative electronics and high-resistance plastic materials ensure durability over time. Available in two interfaces – standard parallel and ccTalk serial. Supplied with quick-release plate.



3 DIFFERENT COIN BOWL SIZES



# Evolution Hopper

## High dispensing speed and reliability come together

Based on a belt drive, Evolution Hopper is excellent in terms of both performance and ease of maintenance. The unique concept provides a single build type hopper that is suitable for 95% of the world's coins and tokens without needing adjustments. A large DC motor in combination with an electronic motor control board yields reduced friction and motor noise. The optic board is easily accessible by removing the electronic control board from outside the hopper.

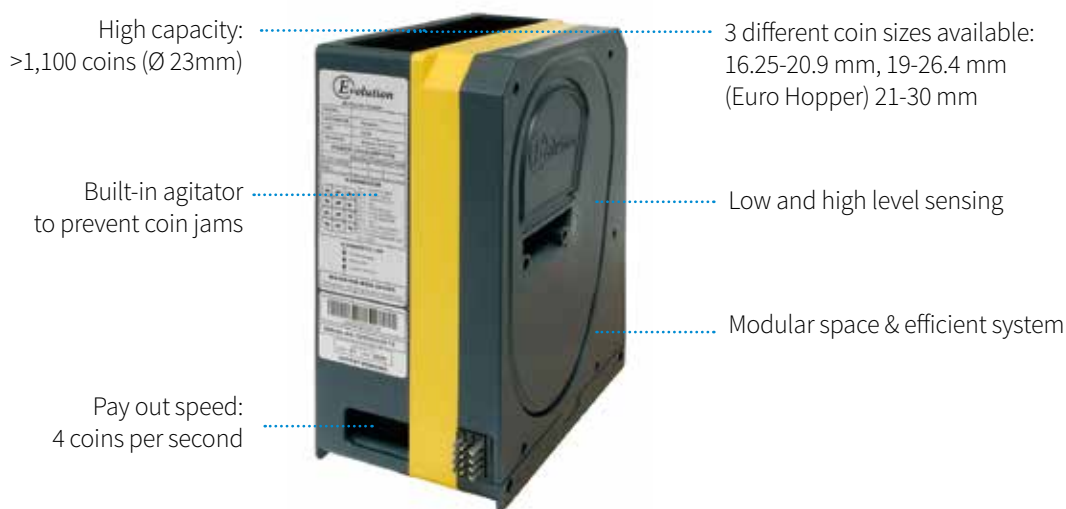

# Excel Hopper

## Extremely durable and the most service-friendly casino hopper

Its gearbox system design provides advantages such as maximum torque with minimum power consumption, unique bayonet motor connection for easy motor replacement, and an easily-accessible coin exit. Available with 3 different bowls: standard bowl, wide or narrow bowl and extended bowl.

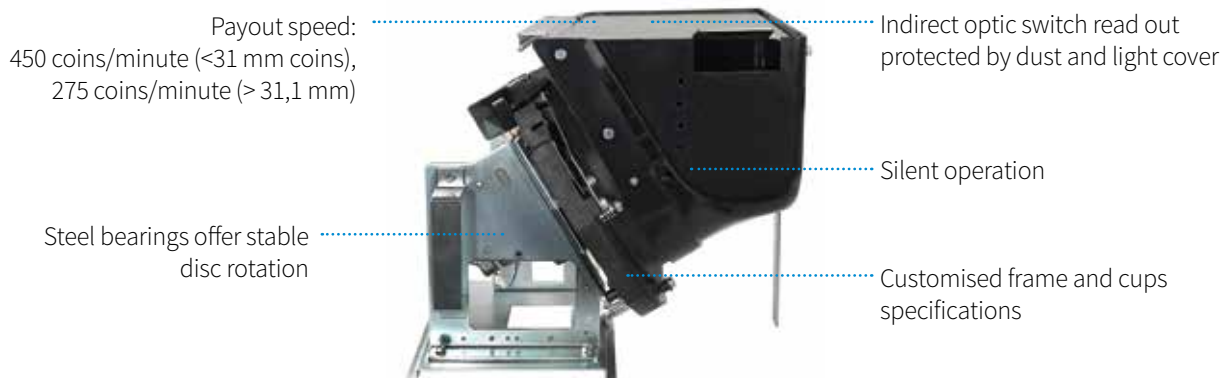

# ICS (Intelligent Coin System)

## The innovative coin handling device

The ICS is a revolutionary coin handling device able to process up to 8 different size coins without the need of pre-sorting the coins by the user. Due to its compact design and spacious size (up to 1,300 various sized coins), it is ideal for many applications, and supports a minimum coin-in to coin-out height solution. Thanks to its patented design and SUZOHAPP's long-standing experience in coin handling, this device is the world's first currency solution able to be integrated into machines from diverse markets including parking ticket machines, self-checkout stations, money changers, kiosks and vending. ICS's intelligent interface gives you the possibility to directly manage the payout composition or make the calculation itself as to the amount of coins per type to be supplied based on the denomination it holds. It is also able to dispense 4 coins simultaneously.

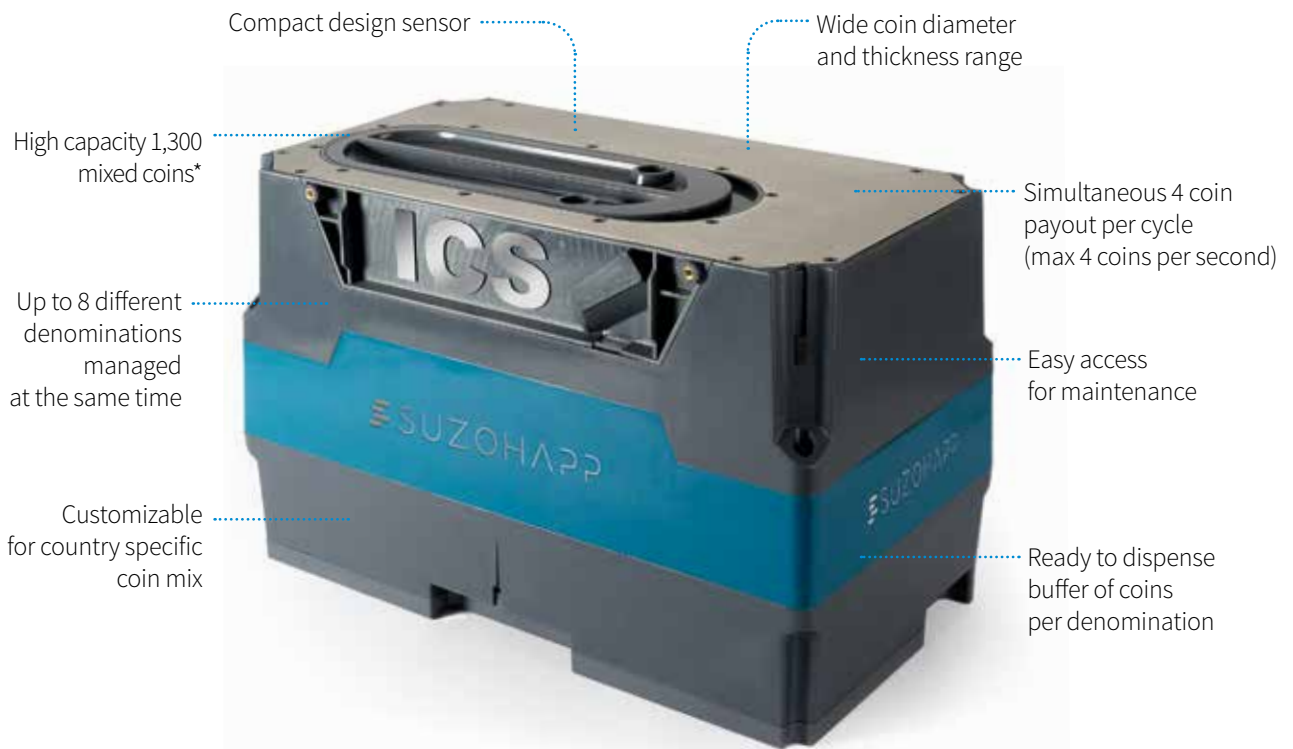

\* value can change according to currency

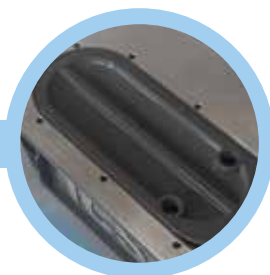

Compact design: one product that works as 8 hoppers + 1 sorter



High payout speed and safety: it guarantees the correct payout per coins' denominations



# MFL®

## Industry's most reliable, secure, modular design

MFL® is the first ever front load banknote validator designed for automated cash transaction applications. MFL® provides modularity and high security due to unique multi-sensor technology. MFL® utilizes a patented alignment mechanism enabling a high acceptance rate for banknotes and barcode vouchers. Due to its robust design and higher reliability, MFL® lowers total cost of ownership, enhances protection against counterfeits and improves machine uptime.

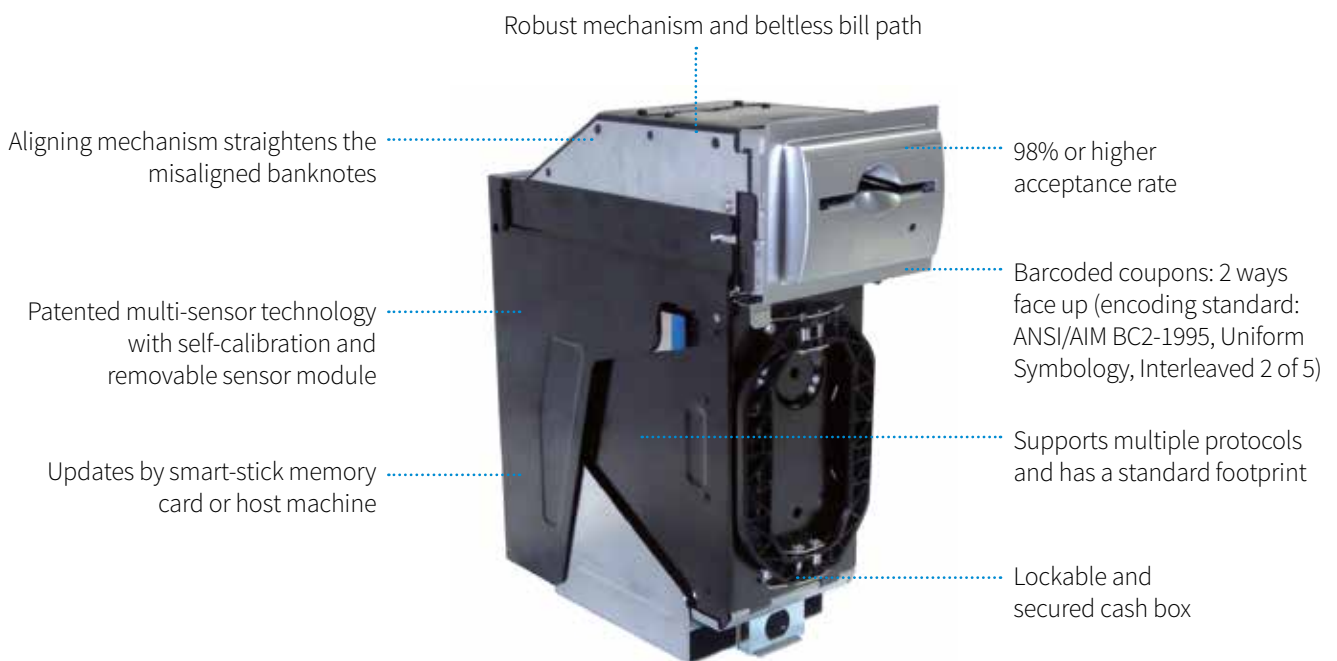

# NV200 Spectral

## The most technically advanced bill validator in its class

The NV200 Spectral is a highly secure banknote validator. State of the art spectral sensors offer complete note image capture (highest spectral coverage) to authenticate the validity of notes. The unit boasts 99%+ first time acceptance of new and street grade notes with a note to note processing time of 2 seconds. The unit contains a number of security features including optical and mechanical anti-stripping technology that delivers outstanding fraud protection. The NV200 Spectral's cutting-edge note centring mechanism together with 4-way barcode acceptance bring the user exceptional note handling and increased ticket acceptance rates.



# Spectral Payout

## Unrivalled mixed denomination recycler

The Spectral Payout boasts superior mixed denomination note recycling and the most technically advanced note validation technology. An 80 note 'true' mixed denomination recycler the Spectral Payout can store all denominations from a given currency, eliminating coin starvation & reducing the coin float level required to keep machines operational. Auto-centering technology straightens notes before reading and all notes in the Spectral Payout can be transferred to the cashbox for easy collection.



## NV9 Spectral

The NV9 Spectral is a highly secure and technologically advanced banknote validator, offering casino level security at a mid-range price. State of the art spectral sensors provide high resolution imaging, scanning 1.28 million data points to authenticate the validity of notes. This versatile banknote validator can be mounted horizontally or vertically, with cashbox and bezel options to suit all applications and a micro SD card for data logging. A note float module can be added to provide note recycling capability.

**NEW**



Full note high resolution imaging - 1.28 million data points

Faster note to note processing

Optical and mechanical anti-strimming technology

Modular design – recycler or ticket printer available

Various cashbox and bezel options

Easy maintenance, free firmware updates

## NV22 Spectral

The NV22S is a market leading, compact mixed note recycler. Combining an NV9 Spectral banknote validator and 'Multi Note Float' payout unit the NV22S can store and recycle up to 40 mixed notes. The NV22S maximises cash efficiency and reduces coin starvation, significantly reducing operational costs. The NV22S comes with a standard 300 note capacity cashbox and uses eSSP (encrypted Smiley Secure Protocol) or ccTalk. The NV22S leaves the factory pre-set to at least one currency so is ready for immediate installation.

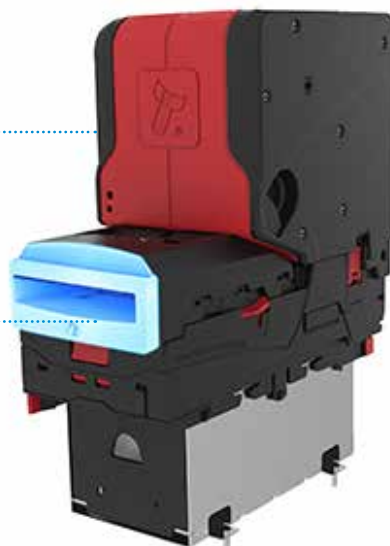

Mixed denomination compact note recycler

Significantly reduces operational costs

Maximises operational efficiency and up-time

Full note high resolution imaging

**NEW**

## NV10 USB+

The NV10 USB+ is a compact, stackerless banknote validator suitable for most applications. Accepting over 100 different world currencies the NV10 USB+ is a truly global product. With a field-proven validator, the unit supports industry-standard protocols and is simple to integrate and maintain.



## ICU

The ICU quickly and accurately determines customers suitability to access age-restricted goods/services. ICU from Innovative Technology Ltd. is a complete hardware and software solution, employing machine learning, to estimate age. In the first investigation, the ICU was placed in two real world settings to test the accuracy when automatically detecting under 18s. The accuracy from the ICU device was shown to be 96%. The device was also compared to the average human ability in quantifying age. It was shown that the device significantly outperformed the average human in estimating a number of age ranges.



## Cleaning Cards



Note Acceptor Cleaning cards  
29-0329-20



Card Reader Cleaning cards  
29-0329-10



Thermal Printer Cleaning cards  
29-0005-00

# Bill-to-Bill 300™

## Advanced sensors technology for Gaming applications

Bill-to-Bill 300™ is the multi-width front load bill recycler with high acceptance rates and superior counterfeit detection due to its patented technology. It is characterized by an advanced sensors technology that improves authentic bill recognition and protects against counterfeits. The validated bills are distributed between three recycling cassettes and one lockable/removable drop cassette. A maximum of 3 denominations may be directed to the recycling cassettes, with the remainder directed to the drop cassette.

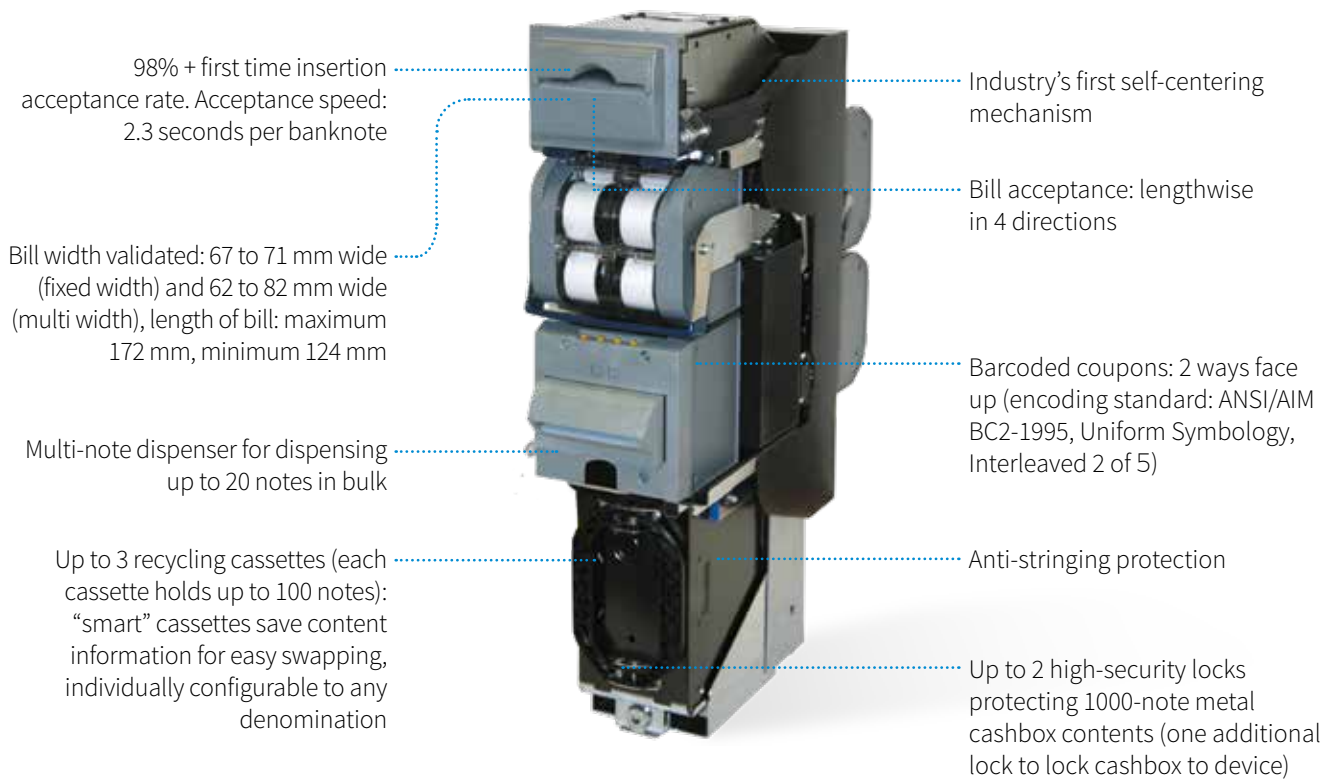

High acceptance rates



Multi-note dispenser



Lockable and removable drop cassette

NEW

# Kiosk / Self-Service Printers

Top technology for almost 30 years



## MODUS 3 Small footprint kiosk printer

Ultra compact thermal printer to meet the needs of slim-line kiosks without sacrificing features and functionality. MODUS 3 combines all the features of a self-service printer in a compact package (116Lx50Dx62H).



## TG02H Extremely compact and versatile ticket printer

Designed for easy installation and panel mounting, the TG02H is an extremely compact and versatile ticket printer and includes a patented anti-jamming system.



## TG1260HIII 60mm ticket / receipt printer

60mm receipt and ticket printer with a metal frame and paper mouth with blocking system to prevent insertion of items. Available in cutter and tear-off versions, 24V version (TG2460), and with illuminated plastic bezel.



## TG2480HIII 80mm ticket / receipt printer

80mm receipt and ticket printer with a metal frame, static presenter, and an exclusive patented anti-jamming system.



## VKP80III 80mm ticket / receipt printer

The worldwide best seller in the kiosk industry! The most compact 80mm ticket and receipt printer with fast printing and low TCO (Total Cost of Ownership). Available with shutter for outdoor use to prevent introduction of objects.

## Lottery & Sports Betting



### KUBE II LOTTERY

#### Printer for lottery, gaming and betting

KUBE II LOTTERY is a high-performance thermal printer suitable for applications in the lottery and betting sector. It features high-quality printing combined with sturdiness and reliability, along with stacking capabilities.



### KUBE II SCANNER

#### Printer for lottery, gaming and betting

KUBE II SCANNER is the combination of a high-performance scanner for cards and betting slips and a high-speed thermal printer with stacker unit. Featuring embedded OMR and barcode reading capabilities for coupons and betting slips and a ticket void feature. One product for a complete solution!



### K3 LOTTERY

#### Printer for lottery, gaming and betting

K3 LOTTERY is the new Custom printing solution designed for the lottery, gaming and betting sectors, with an 82.5mm paper width and 203mm roll diameter to ensure exceptional functionality. Motorized stacker, up to 100 tickets with patented anti-jamming and auto-recovery system.



### SILK

#### Fast and compact PC POS with an innovative and refined design

SILK, a fast and compact ANDROID PC POS for lottery and betting applications. Available with a 13.3" or 15.6" flat PCAP touch display, and an optional secondary customer display.



## Orizon™ NextGen™ Smarter. Faster. Better.

The ultimate kiosk printer, combining technology (PC-based infrastructure), flexibility (adjustable spindle arm) and outstanding reliability (200km print head life).



## PayCheck® Terminal™ Low-cost hardware for interactive kiosks.

PayCheck Terminal XL is the world's first kiosk terminal powered by a TITO printer. Taking advantage of the power and uniqueness of the PayCheck NextGen printer, we created a Linux-based terminal for your gaming, lottery and retail applications.



## PayCheck® NextGen™ The 'ONE' printer you need!

Greater value, more reliable and more capable than any of its competitors on the market today, PayCheck NextGen is the 'One' printer venues need to ensure reliability, functionality and connectivity.



## PayCheck® 4™ Fastest. Smartest. Toughest.

Finally, there's a printer that's as fast as the gaming action on your casino floor. The PayCheck 4 Thermal Printer from Nanoptix® can print a ticket in just 0.6 seconds!







## PayCheck® Desktop 2™

The newest member of the PayCheck® series family

Powered with PayCheck NextGen technology, this desktop model can enhance your cage environment by providing your customers quick TITO tickets, promotional coupons and/or streamlined tax forms, to name a few, while keeping your host engaged one-on-one with your patrons.



## HSVL Advanced™

Better. Smarter. Faster.

The HSVL Advanced printer, provides manufacturers ultimate flexibility and outstanding reliability. By using innovatively designed movable spindle arms the HSVL Advanced can adapt to any kiosk design.



## EZ-Tear™

Compact. Flexible. Modular.

The EZ-Tear printer provides manufacturers flexibility while remaining compact and reliable. Built with modularity in mind, the EZ-Tear printer will fit many types of kiosks and with its clamshell design, provide easy access for paper loading.



## “Spill-Proof” Thermal Printer

Fast. Quiet. Efficient.

Affordable and easy to use. Best of all, its patent-pending spill-proof design means never having to worry about OOOPS again. IEC60529, IPX3 spillage approved.

## Slot Machines Tickets

Superior quality slot machine tickets, from blank stock tickets to customized tickets with 4-way repeat backside print. Tickets are approved for use in International Game Technology's (IGT) EZ-Pay™ and Sierra Design Group's (SDG) voucher systems.

- ✓ Unlimited color possibilities and 4-color printing processes provide photo realistic quality and color reproduction
- ✓ Digital proofing systems guarantees the best match to press
- ✓ Reliable and flexible security options protect against fraud
- ✓ On-the-spot authenticity verification with thermochromic, blacklight visible UV and coin-reactive inks

## Customized Tickets

Possibility to have 4 different designs on the backside of the ticket, this is a so-called 4-way repeat print, where you can choose any 4 designs which will be repeated every 4 tickets.

This is especially interesting to promote special offers from restaurants or specific games.



# Redemption Tickets and Dispensers

## Deltronic Ticket Dispenser

- ✓ “Snap out” one ticket dispenser – replace it with another in seconds
- ✓ No tools necessary
- ✓ Foolproof braking system is easily adjustable
- ✓ Validation “Diamond” mark identifies tickets
- ✓ Available as Continuous or Pulse type

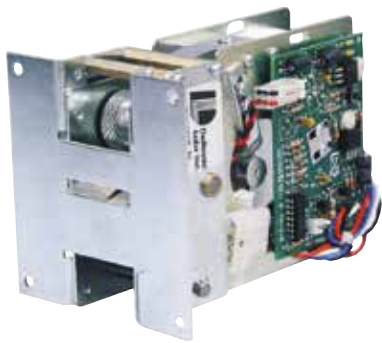

## ENTD-2000 Ticket Dispenser

- ✓ Virtually eliminate ticket jams
- ✓ Requires very little maintenance
- ✓ One of the most reliable and compatible ticket dispensers on the market

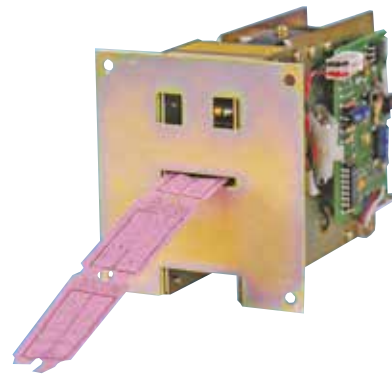

Tickets can be personalized to your requirements

# Door Switches

## Single and Double Pole

- ✓ Choice of push and push-pull interlock switches
- ✓ Snap-in panel mounting
- ✓ Long-life coil spring, snap-action mechanism
- ✓ Temperature rating -40° to +85°
- ✓ Flammability rating UL94V-0
- ✓ Various approvals available
- ✓ Detailed datasheets available



# Cooling Fans



## DC Cooling Fans

- ✓ Compact cooling fans
- ✓ Wire connection
- ✓ 12 or 24 Vdc
- ✓ Speed up to 5800 RPM

## AC Cooling Fans

- ✓ Protects electronics from overheating
- ✓ Easy mounting with 4 bolts
- ✓ Terminal or wire connector
- ✓ Speed up to 3000 RPM



## Finger Guards for Cooling Fans

- ✓ Protects electronics from over heating
- ✓ Easy mounting with 4 bolts

# Stationary Scanners

Newland scanners are supported by EasySet – a software tool for configuration, cloning setup for fast deployments, firmware upgrades, imaging functions, and includes a barcode generator.



NEW

## FM3080

Impressive short-range scanning capabilities combined with customization

Prepared for integration in your kiosk or counter, the FM3080 Hind combines performance and customization. The large scan window is optimized for short range reading of barcodes from a mobile phone or paper, even placed directly on the glass. With 4 color options available, the FM3080 Hind can be easily programmed to indicate a successful read or to match your brand.



## FM100

Reading performance reaches and exceeds global standards, advanced CCD scan engine

Designed for OEM applications, this high-performance fixed scan engine can easily be integrated into various solutions such as kiosks, ticketing machines, (reverse) vending machines and many more. CCD technology means no laser, mirror or moving parts for increased durability.



## FM430 Barracuda

Read barcodes from short or long range with this compact scanner for when less space is available

The new FM430 Barracuda is Newland's most aggressive and efficient fixed mount scanner to date, making it a strong all-around solution. It's equipped with a megapixel camera that scans virtually any 1D and 2D barcode with impressive speed and ease. On top of that, its programming, IR sensor and light sensor help keep users moving, even in low light conditions. The combination of these features makes the device a leader in its class.



## FM3051 Grouper II

Plug-and-play simplicity enhancing your experience right from the start

With its snappy barcode reading of virtually any 1D or 2D barcode, the FM3051 Grouper II is the perfect response to the trend of barcodes moving from paper to the screen. Built to read from contemporary LCD widescreen devices, the fixed scanner is ideal for mobile phone applications like loyalty programs and ticket validation. Whether it's an employee scanning a product label or a customer scanning a voucher on their mobile phone, barcode scanning is always easy and quick. The form factor and small footprint of the FM3051 Grouper II makes it easy to integrate into a kiosk. Also available in flush mount: the FM3056 Grouper II.



## FM3056 Grouper II

Plug-and-play simplicity enhancing your experience right from the start

The FM3056 Grouper II is a flush mount scanner with a minimal footprint. With a height of only 53mm, the device is small enough to fit into most kiosks, while the flush mount ensures that the device suits any business environment. Built to read from contemporary LCD widescreen devices, the fixed scanner is ideal for mobile phone applications like loyalty programs and ticket validation. Whether it's an employee scanning a product label or a customer scanning a voucher on their mobile phone, barcode scanning is always quick and easy. The FM3056 Grouper II is the flush mount equivalent of the FM3051 Grouper II.



NEW

## FR27

Latest technology, compact design, CPU-based scanner

Armed with Newland's latest-generation UIMG® technology, the FR27 can decode poor quality soiled or wrinkled barcodes with ease, even on a screen covered with protective film. Its exceptional motion tolerance and large FOV enhance the user experience. Fits on a narrow desk or shelf when space is at a premium.





### FR21 Neon

Ideal desktop scanner for mobile payment, customer loyalty and ticket verification

The FR21 Neon was built to create an optimal customer experience at the POS. It scans quickly and easily, even for the most inexperienced user, making it an ideal solution for applications like mobile payment, customer loyalty, cashback, and ticket verification. "Scan here" circle customizable with any sticker.



## OEM Scan Engines



### EM2037-V4

Delivers speedy and accurate scanning performance

No matter what type of barcode is presented, the megapixel camera allows users to scan 1D and 2D barcodes, including very small ones, with impressive speed and ease. In addition to excellent scanning of high-density barcodes, the EM2037-V4 also provides the added value of decoding postal barcodes.



### EM3080-W

Small, lightweight and easy for integration

The EM3080-W is Newland's smallest OEM scan engine. Including easy integration with a minimal footprint, the EM3080-W is the perfect solution for all-around scanning capabilities.



### EM2080

Snappy on-screen barcode capture

The CPU-powered EM20-80 is incredibly reader-friendly on smartphone and tablet displays, and features excellent near-field reading, a wide viewing angle and snappy reading.



### EM3396

Integratable into various OEM devices including kiosks, ticket validators, and PDA's

The EM3396 OEM scan engine with a bright laser aimer, offers stunning performance on 1D and 2D barcodes. It can be integrated into various OEM devices including kiosks, ticket validators and PDA's. Due to its light weight of only 4g, solid-state build and low power consumption, the engine is ideal for portable scanning devices.



### EM50S-10

Superior scanning performance

The EMS0S-10 / EMS0S-20 is a CPU-based scan engine that delivers stunning performance. Armed with Newland's sixth-generation of UIMG technology, decoding damaged or poor-quality barcodes is no match for this scan engine.



### EM1300

Compact and highly integrated design

Designed for OEM applications, this high-performance CCD scan engine can easily be integrated into various solutions such as kiosks, ticketing machines, PDA's and many more.



# Pay Connect™

NEW

## Accelerate your kiosk development

The new solution – PayConnect™, is the perfect platform for systems builders and kiosk manufacturers. PayConnect allows the builder/manufacturer to rapidly develop and integrate their solutions with a broad range of cash and digital payment components. Based on the industry leading CashComplete™ On-Device software engine, this all-in-one solution provides the hardware and software required to quickly build and deploy self service solutions that incorporate all forms of payment, including notes, coins, debit, credit, digital wallets and various closed cashless systems.



## Smart connectivity for outstanding performance and control

The value of PayConnect doesn't end once the system is built. With full integration to CashComplete Connect, you get the power of enterprise device, user monitoring and management, as well as payment and utilization reporting and analytics. All through an easy to use, cloud-based, web interface that is fully mobile capable.

## Be part of the payments ecosystem

Extend the reach of your solution by incorporating it with other CashComplete On-Device based systems. By combining PayConnect based self-service solutions with enterprise cash recyclers, high speed smart safes and point-of-sale platforms, your self-service solution becomes part of the CashComplete Connect payments ecosystem.

## Supported peripherals:

- ✓ Monitors and touch screens
- ✓ Cashless readers open and closed loop
- ✓ Banknote readers and recyclers
- ✓ Coin validators and coin changers
- ✓ Coin hoppers
- ✓ Card/box dispensers
- ✓ Printers
- ✓ Barcode scanners
- ✓ Proximity sensors
- ✓ Speakers
- ✓ UPS
- ✓ Generic I/O interface boards to activate power services (relay based)





# Charge'N Play

## Add USB Charging capabilities to your machines

Charge'N Play is the innovative dual USB charger – easy to install and simple to use, and a magnet for customers. Charges up to 2 electronic devices through the USB port. Charge'N Play can be installed in cabinets or integrated in the wall.

- 2 USB ports
- Top or side mount module
- Optional installation kit
- Designed to mount easily to wood or metal cabinet
- Optional 3-way micro-USB cable (1m length) lighting connector
- Compatible with popular mobile devices



Also available as kit, with cable, wobbler and power supply



Built-in Kit



Built-up Kit



## Available with Charge'N Play

### Lumia RGB Infill Panel

#### Features

- ✓ Pleximilchglas with RGB LED lighting and remote control
- ✓ High quality soldering iron stand
- ✓ Front panel can be easily removed (3 screws)
- ✓ Different colours adjustable, as well as various flash modes and a colour change programs
- ✓ Very discreet, non-glare lighting
- ✓ Dimensions: 95cm x 35cm x 47cm



### Protec Alarm System

#### Features

- ✓ 12/24v DC operation
- ✓ Battery Back up
- ✓ Uses accelerometer - no external Tilt Switch necessary
- ✓ Automatic arming (if required)
- ✓ External LED indicator
- ✓ Spares available upon request



## Speakers

A wide range of speakers with terminals perfect for use anywhere a small footprint speaker is needed. Available in various sizes and voltages.



## PowerPro Power Supplies

200W, 400W and 500W

SUZOHAPP has the power supplies you need, now featuring label and connector artwork on our website, to ensure you get the right power supplies every time.





## Joysticks

- ✓ Supplied with microswitches with 4.8 mm or 6.3 mm
- ✓ Realistic spring action
- ✓ Available with 4 or 8 ways
- ✓ Ergonomic handle for comfortable grip



## Trackballs

- ✓ Exceptional performance
- ✓ Custom colors available
- ✓ No external power supply needed
- ✓ Ease of use



## Driving Controls

### Sturdy 2 - Position Shifter

- ✓ Microswitch operation
- ✓ Standard mounting



### Steering Wheel

- ✓ Ball bearing construction
- ✓ Potentiometer control
- ✓ Standard mounting



## LED Light Strips



Controller & wireless remote sold separately

Attract more attention and increase your earnings!

- ✓ Easily installs in or around your machine station and increase earnings
- ✓ Great for amusement parks and games, casinos, slot machines, arcades, family entertainment centers, theaters, backlighting, decorative lighting, etc.
- ✓ Ideal way to increase earnings on your cranes and pushers
- ✓ Very thin continuous length flexible LED light strips
- ✓ 5m rolls can be separated every 3 LEDs and reconnected again
- ✓ Super bright high-quality SMD LEDs per reel with 120° wide angle illumination
- ✓ 3M adhesive tape on back for easy installation

- ✓ Operates on +12VDC power supply (150-0072)
- ✓ Solid state, high shock or vibration resistant
- ✓ LEDs controlled by controller and wireless remote (sold separately)
- ✓ Each controller can run 65.62 feet (20 meters) of LED strips
- ✓ Long life: 50,000 hours
- ✓ Less power consumption than traditional lights
- ✓ No RF interference
- ✓ Sold in reels of 5m
- ✓ +12VDC; 20W

## Adhesive LED Strip Lighting



## Lamps

### Light PRO LED Tubes

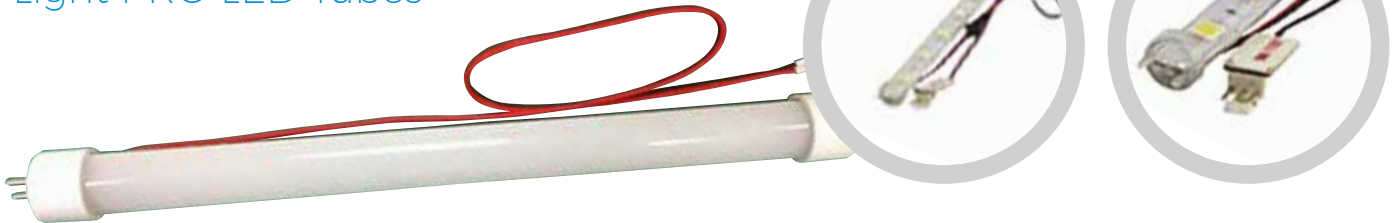

## Counters

### SEC Starpoint Electronic Counter

Enhanced security is a major feature of the SEC, a unique fingerprint code allows the machine to detect any meter changes and to prevent operation if the meter is not present. By utilizing the latest electronic technology, the SEC avoids the reliability problems and service call-outs which can be experienced with mechanical counting devices.

- ✓ Replaces up to 31 mechanical meters with individual counters stored in EEPROM
- ✓ 7-digit LCD for displaying contents of counters
- ✓ Text messages and counter selection controlled by host machine
- ✓ Clocks serial interface designed to work on existing meter ports
- ✓ Improved security through:
  - Secure software protocol
  - Tamperproof counters with unique fingerprint code



## Proximity / Motion Sensor

- ✓ Detects changes in position within a zone up to 5 meters
- ✓ Easy to use – sensor simply changes its output from 0 to 1
- ✓ SUZOHAPP part number 2051400000184A

Detection distance	5m
Field of view	22°x38°
Detection zone	24 beams
	The temperature difference between the target and the surroundings must be higher than 4°C
	Movement speed: Digital output 0.8 to 1.2m/s Analog output 0.5 to 1.5m/s
	Target concept: Human body with an approx. size of 700x250mm
	Target moving direction: Crossing the detection beam



# The Ultimate **Electronic Reprogrammable Lock**

Secure, remote access control with operational visibility

Identifies each user, checks permissions, records each operation



Patented high-tech stainless-steel locking system with self-powered key sets

## Features

- ✓ Never again change locks when a key is lost, or employee dismissed
- ✓ Carry far fewer keys for your fleet or location
- ✓ Drop-in replacement for existing locks – self-powered, no wiring
- ✓ Remote authorization and traceability with Bluetooth option
- ✓ Automatically logs access times and user – no more manual logging
- ✓ Authorization reissued daily, or on demand
- ✓ Grant temporary access to technicians or others

## Design

- ✓ Standard cam or cylindrical formats, custom sizes available
- ✓ 90°, 132°, 180° rotation limiters, right and left
- ✓ P65 for outdoor usage
- ✓ AES 128-bit encrypted communication
- ✓ Over 10 billion combinations



### Bluetooth Connectivity

Fully control your locks from any remote location even from a smartphone or a tablet

Program a Unique-Code for each lock with multiple User Key access, or Multi-Code to pair each lock with multiple key codes for a hierarchical or simple master key system.

## Keys



**Master Key**  
 Programs lock pairing with User and Download Keys



**User Key**  
 Unique-Code or Multi-Code



**Download/Audit Key**  
 Retrieve access history stored in locks



**Bluetooth Key**  
 Communicates with smartphone or tablet to headquarters

## Accessories



**Cylinder Adapter**



**Handles and Covers**

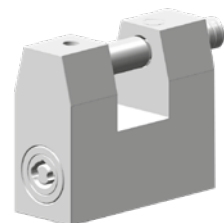

**Padlock**

## Software

- ✓ Retrieve lock history with the Download Key, insert in supplied USB Pod, and display/export the event history
- ✓ Create and check permissions, black and white lists, reprogram keys, set access time limits, monitor and control each operation
- ✓ Communicates from headquarters to iPhone or Android smartphone/tablet apps, and then to users' Bluetooth Keys
- ✓ Runs on a secure Cloud-based platform or your own server

Contact SUZOHAPP for a trial kit compatible with your existing locks!



## VENIA Locks & Keys

### Venia Security Switchlocks DPST



- ✓ 14 pin system, 10 pins on the flat key side and 2 side pins on each side
- ✓ Brass housing with high quality spindle and bright chrome finish
- ✓ A security collar is included with every Venia lock to prevent any attempts to turn the lock with tools
- ✓ Key made of nickel silver assures longer lifetime and trouble-free operation
- ✓ Only available as key different
- ✓ Connection by 4 solder terminals
- ✓ 2 different switch configurations: pos. 1-3 on/off, pos. 2-4 off/on

### Venia Security Camlocks



- ✓ 14 pin system, 10 pins on the flat key side and 2 side pins on each side
- ✓ Brass housing with high quality spindle and bright chrome finish
- ✓ A security collar is included with every Venia lock to prevent any attempts to turn the lock with tools
- ✓ Key made of nickel silver assures longer lifetime and trouble-free operation
- ✓ Camlocks are available in 3 different lengths: 16 mm (5/8"), 22.3 mm (7/8") and 28.6 mm (1-1/8")
- ✓ Standard 2 position 32 mm cam included

### Venia Security Switchlocks



- ✓ 14 pin system, 10 pins on the flat key side and 2 side pins on each side
- ✓ Brass housing with high quality spindle and bright chrome finish
- ✓ A security collar is included with every Venia lock to prevent any attempts to turn the lock with tools
- ✓ Key made of nickel silver assures longer lifetime and trouble-free operation
- ✓ Venia switchlocks are available with and without automatic key return

### Venia Keys



- ✓ Venia keys can only be ordered through SUZOHAPP
- ✓ Key made of nickel silver assures longer lifetime and trouble-free operation
- ✓ These keys can be cut to your specific key code

## Xlocks & STC Locks

### Security Camlocks Key Alike



- ✓ 10 pin operation
- ✓ Die cast housing with chrome finish
- ✓ Camlocks available in 3 lengths: 16 mm (5/8"), 22.3 mm (7/8") and 28.6 mm (1-1/8")
- ✓ Large key provides good grip during operation
- ✓ Key made of nickel silver material for trouble-free performance
- ✓ Standard supplied with 32 mm cam with dual hole so the lock can be mounted in any position

### Security Switchlocks



- ✓ 10 pin operation
- ✓ Die cast housing with chrome finish
- ✓ Length 36.4 mm (1-7/16")
- ✓ Large key provides good grip during operation
- ✓ Key made of nickel silver material for trouble-free performance
- ✓ Switchlocks have 6.3x0.8 mm terminals fitted for easy connection
- ✓ Switchlocks are available with or without automatic key return

### STC Round Key Camlocks

High reliable range of camlocks of different sizes to satisfy customer needs. Locks are available both as key different

- |   |   |
|---|---|
| <ul style="list-style-type: none"> <li>✓ 7-pin tumbler lock</li> <li>✓ Housing with chrome finish</li> <li>✓ Round chrome plated key</li> </ul> | <ul style="list-style-type: none"> <li>✓ Available as key different and key alike</li> <li>✓ Available in: 16 mm (5/8"), 22.3 mm (7/8") and 28.6 mm (1-1/8")</li> <li>✓ Cam included</li> </ul> |
|---|---|

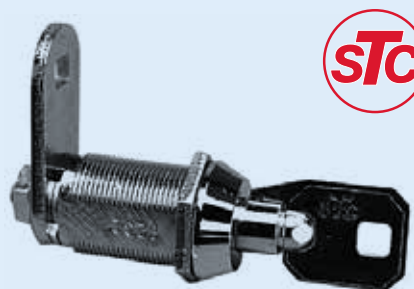

All new key alike series are supplied in lots of 25, 50 or 100 pcs with a total of 5 keys per key code. Re-orders on the same key code are possible with a minimum of 25 locks per key code.

## Security Bars

### Universal Security Bar

- |  |  |
|--|--|
| <ul style="list-style-type: none"> <li>✓ Designed to be used with a padlock (not included)</li> <li>✓ Heavy duty steel</li> <li>✓ Telescopic adjustable 40 - 85cm</li> </ul> | <ul style="list-style-type: none"> <li>✓ Supplied complete with hardware</li> <li>✓ Not recommended for pedestal cabinets</li> </ul> |
|--|--|



### Adjustable Security Bar

- |  |  |
|--|--|
| <ul style="list-style-type: none"> <li>✓ For Changers, small Cabinets and other games</li> <li>✓ Adjustable from 25 to 40 cm</li> <li>✓ Easy installation</li> </ul> | <ul style="list-style-type: none"> <li>✓ Made from durable steel with black finish</li> <li>✓ Simple mounting with provided hardware</li> <li>✓ After installation, only a 12 mm hole needs to be drilled in hasp to fit padlock (not included)</li> </ul> |
|--|--|



Specially designed for all types of Coin Operated equipment

# ASSA Desmo Locks

## Desmo Casino Locks

With many of the world's largest casino groups as a customer the product has become a standard for any casino operator who insist on maximum security combined with maximum operating comfort. The Assa Desmo is a patented lock construction based on direct drive pins (no spring operation) making it particularly suitable for many operations in dirty and hostile environments. False cuts on the pins provide resistance to any currently known method of picking. The Assa Desmo system is the effective way to prevent unauthorized manufacturing, cutting and distribution of key blanks, it also requires the most advanced and precise key cutting equipment in the lock industry.

- 8-pin lock combined with two strong side bars
- Large key made of nickel silver for lasting durability and comfortable operation
- Standard 90 degrees operation and key removable in locked position
- Various collars available to adjust any mounting depth
- Standard supplied with 32 mm cam, other sizes and models available
- Key-different locks are supplied with 2 keys per lock

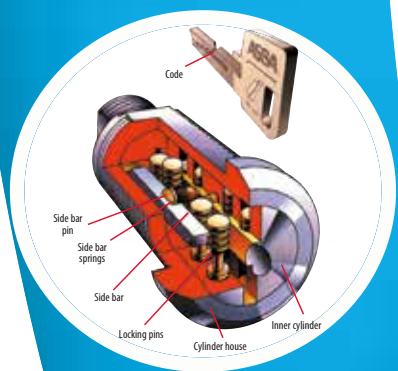



# Customizable Cabinets

## 4 Configurations Available To Suit Every Need

SUZHOPP cabinets are the perfect start for your next game launch. Simply plug in your game board to our pre-fabricated metal cabinets. Available in four basic configurations: The SoloPro with a single 21.5" LCD touchscreen, the SoloPro XL<sup>32</sup>, with a single 32" vertical touchscreen, the DualPro a dual screen cabinet with a 21.5" touchscreen and 21.5" non-touch LCD, and introducing the SoloPro XL<sup>42</sup> with a single 42" vertical touchscreen.



## Compact RGB Handle Mechanism

- ✓ Ultra low-profile design allows for external mounting on cabinet and provides increased space inside of the cabinet
- ✓ Easily to remove for improved serviceability
- ✓ Ruggedized die cast design to provide long-term performance
- ✓ RGB attract mode on handle mechanism cover to attract additional attention
- ✓ As handle is pulled LEDs light up with each of the six clicks of the handle movement. All LEDs light up when handle is fully pulled
- ✓ Pre-programmed with unique flashing patterns and color combinations
- ✓ RGB illuminated mechanism ball with 2 multi-color LED's that flash, glow or flash light patterns to further trigger your interest in your handle machines
- ✓ 45° rotation



## Custom Reel Mechanisms

Custom engineered reel mechanisms to fit the needs of our customers



# Custom capabilities



What you imagine, **we create!**

## CHAIRS

### Zenith

- ✓ Eco leather fire-retardant, water-proof, stainproof (certificate 300,000 cycles anti-abrasion)
- ✓ Padded ergonomic polyurethane foam to varying hardness
- ✓ Base: chrome diam.500 mm conical reinforced steel
- ✓ Swivel and up & down 58 cm to 84 cm (suitable for both slant top and high cabinet both)
- ✓ Base is 55 diameter - maximum height of backrest is 103 cm (minimum) and 128cm (maximum)
- ✓ Seat Auto-return 360 degree with auto-centreing breaking friction
- ✓ Finished chromium
- ✓ Exceeded the following tests and certifications: durability test, seat and back drop test, footrest fatigue resistance, resistance to fatigue armrest, stability test



Zenith4  
Base chromed steel in 4 legs

### The Carrillo

- ✓ Eco leather fire-retardant (certificate 300,000 cycles wear resistance)
- ✓ Padded ergonomic polyurethane foam to varying hardness
- ✓ Structure in reinforced steel with welding anti-break
- ✓ Finished chromium (three chromium)
- ✓ Available in height 73 cm for high cabinet or 55 cm ideal for slant top
- ✓ Exceeded the following tests and certifications: durability test seat and back - drop test - footrest fatigue resistance resistance to fatigue armrest - stability test
- ✓ Personalised artwork available



The Carrillo

Bebe Carrillo



39-0084-1

39-0084-1A

Available in two sizes

### Apollo

- ✓ 360° rotation
- ✓ Adjustable seat height
- ✓ Free running backrest
- ✓ The six flat double wheels cannot be seen due to the cover and can support a load of 300 kg. Ideal for carpets and hard flooring
- ✓ With its teflon gliders, the chair slides smoothly over the floor without damaging it. Even when heavily loaded. No scratches, no streaks or other mark
- ✓ Spare parts are fast delivered and are quick and easy to replace



### Air Hockey Puck Twister

- ▶ Available in 70mm and 80mm diameter
- ▶ 4 neon colours: orange, white, yellow and blue
- ▶ Colours light up when black light tube is used
- ▶ Customer logo available to order (minimum 1000 in one colour, one time tooling cost applicable)
- ▶ 70mm pucks



30-0070-3301 Orange  
 30-0070-4401 Yellow  
 30-0070-6601 Blue  
 30-0070-9901 White

### Air Hockey Hammer

- ▶ Universal Hammer for all air hockey games
- ▶ Made of durable material
- ▶ High profile handle to prevent injuries



30-0041-6 Blue  
 30-0041-7 Pink

### Felt Disc

- ▶ Replacement felt disc for Air Hockey Hammer 'Pro'
- ▶ Not suitable for BC1010-1

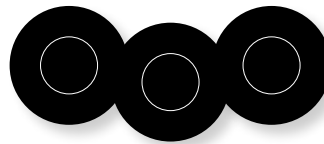

30-0030

### 'Kick It' Football & Tether



AI0225 Tether  
 AI0189 Football

### 29" Pump Action Shotgun for Bick Buck Hunter Pro



96-0476-13  
 29" Pump Action Shotgun, Green  
 96-0476-17  
 29" Pump Action Shotgun, Orange

### Basketballs

- 49-0471-00 – 7" Orange Basketball
- 49-0825-00 – 9" Orange Basketball
- 49-1264-00 – 7" Tri-Colour Basketball
- 49-3020-00 – 5.5" Multicolour Mini Basketball



### Touch Screen Mallet

22-1947-1

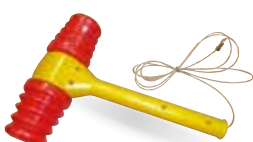

### Small Foam Mallets

22-1949 Red & Yellow  
 22-1946-1 (longer cable 125cm)



### Universal Mallet

51-5000-00



### 'NEON' Glassfibre Pool Cue

- ▶ Almost unbreakable glass fibre pool cue
- ▶ No added weights that can go loose
- ▶ Moulded rubber grip
- ▶ 12 mm Slip-on tip
- ▶ Available in 4 different colours
- ▶ Length 140 cm - 57"
- ▶ Very competitive pricing!

47-0069 Neon Pool Cue Black  
 47-0069-4 Neon Pool Cue Yellow  
 47-0069-6 Neon Pool Cue Blue



### Slip-on Tips

- ▶ Slip-on tips for the Neon Glassfibre Cues

47-1112 12 mm Push-on tips



### 'MATRIX' Glassfibre Pool Cue

- ▶ Besides being almost unbreakable, these Cues look like a real maple Pool Cue
- ▶ Give your players a top quality cue which will last much longer than wooden cues
- ▶ Black handle with 4-prong look
- ▶ Fitted with 12mm plastic screw-on tip
- ▶ Length 140 cm - 57"

47-0085 Matrix Pool Cue



### Screw-on Tips

- ▶ Selected leather on quality plastic M8 thread with 12 mm tip used on most popular 1 piece cue

47-1230-6 12 mm Screw-on tip

### 'MAPLE' Pool Cue

- ▶ Fitted with 12mm plastic screw-on tip
- ▶ 4-prong brown handle
- ▶ Black rubber screw-on bumper
- ▶ Weight approx. 550gr
- ▶ Length 140 cm - 57"

47-0083 Maple Pool Cue



### Plastic Screw-on Tip 12mm

47-1230-6 Screw-on tip

### Rubber Bumper

47-1310 Rubber bumper

### 8-Ball 'MAPLE' Pool Cue

- ▶ Top quality maple pool cue
- ▶ Fitted with 13mm leather glue-on tip
- ▶ 4-prong brown handle
- ▶ 8-ball logo embedded in handle
- ▶ Assorted weights
- ▶ Length 140cm - 57"

26-1633-00 8 Ball Maple Pool Cue



### "Elk Master" Glue-on Tips

- ▶ American made soft blue leather tips
- ▶ Made of special treaded leather
- ▶ Ensured grip and long life time

26-1073-13 Glue-on tip 13mm



### Ash Snooker Cue

- ▶ Quality ash snooker cues
- ▶ Fitted with 9mm glue-on leather tip
- ▶ Available as 1 pc cue in 2 different colours or 2 pcs with brass joint
- ▶ Length 140cm - 57"

- 47-0155 1 pc tan butt
- 47-0156 1 pc dark butt
- 47-0273-9 2 pcs 57" Ash Cue
- 47-0273-48 2 pcs 48" Ash Cue



### The Regent 2-Piece Pool Cue

- ▶ Made of Ramin wood in robust design with a solid grip, brass joint, fitted with 11mm screw-on-tip and screw-on rubber bumper

P4049 2-piece pool cue

### "Elk Master" Glue-on Tips

- ▶ American made soft blue leather tips
- ▶ Made of special treaded leather
- ▶ Ensured grip and long life time

26-1073-9 Glue-on tip 9mm

### Ramin Rest Sticks and Long Cue

- ▶ A complete range of rest stick, half butt cues and rests, long butt cues and rests

- 47-015 152cm - 60" Rest stick
- 47-0157-90 228cm - 90" Half butt cue
- 47-0157-108 275cm - 108" Long cue
- 47-0158-84 213cm - 84" Half butt rest
- 47-0158-96 244cm - 96" Long butt rest

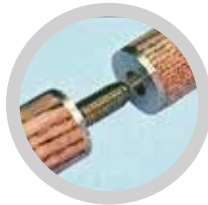

### Rubber Bumper

- ▶ Screw-on-rubber bumper

47-1310 Screw-on-rubber bumper

### 'The Shooter' Pool Cue

- ▶ Good quality ramin pool cue
- ▶ Fitted with 12mm plastic screw-on tip
- ▶ Carved black handle, painted in four prong look
- ▶ Black slip-on rubber bumper
- ▶ Sold in assorted weights
- ▶ Available in 4 different length

- 47-0052 140cm - 57"
- 47-0052-1 130cm - 52"
- 47-0052-2 120cm - 48"
- 47-0052-5 137cm - 54"
- 47-1230-6 Plastic Screw-on Tip 12mm
- 47-1320 Slip-on Rubber Bumper



### 'The Regent' Pool Cue

- ▶ Good quality ramin pool cue
- ▶ Fitted with 11mm brass screw-on tip
- ▶ Black handle, painted in four prong look
- ▶ Black slip-on rubber bumper
- ▶ Sold in assorted weights
- ▶ Available in 6 different lengths

- 47-0050 140cm - 57"
- 47-0050-1 130cm - 52"
- 47-0050-2 120cm - 48"
- 47-0050-5 90cm - 36"
- 47-0050-6 137cm - 54"
- 47-0050-42 107cm - 42"
- P2270 57" non-weighted cue
- P0122 47" non-weighted cue



### Brass Screw-on Tip

47-1240-4 Screw-on tip 11mm

### Push-on Tips

- ▶ Standard push-on tips with bonded pre-shaped tip
- ▶ Available in different sizes
- ▶ Sold in box of 100 pcs

47-1110	11mm	47-1114	13mm
47-1111	11.5mm	47-1115	13.5mm
47-1112	12mm	47-1116	14mm
47-1113	12.5mm		



### Billiard Pro Chalk

- ▶ Competitive price
- ▶ Sold in boxes of 12 pcs
- ▶ Available in red, green or blue

47-0650-2	Red 0.55
47-0650-5	Green 0.55
47-0650-6	Blue 0.55
47-0650-7	Purple 0.55



### Triangle Billiard Chalk

- ▶ Top quality billiard chalk
- ▶ Sold in boxes of 12 or 144 pcs
- ▶ Available in red, blue or green

26-1023-12BT	Blue 12 pcs
26-1023-12RT	Red 12 pcs
26-1023-12GT	Green 12 pcs
26-1023-144BT	Blue 144 pcs
26-1023-144RT	Red 144 pcs
26-1023-144GT	Green 144 pcs

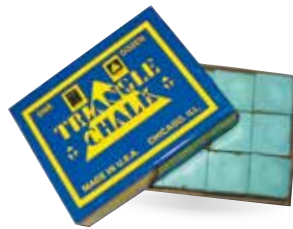

### 'Elk Master' Glue-on Tips

- ▶ American made soft blue leather tips
- ▶ Made of special treaded leather
- ▶ Ensured grip and long life time

26-1073-8	8mm	26-1073-11	11mm
26-1073-85	8.5mm	26-1073-12	12mm
26-1073-9	9mm	26-1073-13	13mm
26-1073-95	9.5mm	26-1073-14	14mm
26-1967-00	10mm		



### 'Silver Cup' Billiard Chalk

- ▶ Strong, hard chalk grips cue tip for more accurate shooting
- ▶ Large range of colours
- ▶ Sold in boxes of 12 pcs or 144 pc

26-1051-12B	Blue 12 pcs		
26-1051-12G	Green 12 pcs		
26-1051-12BK	Black 12 pcs		
26-1051-12BUR	Burgundy 12 pcs		
26-1051-12PW	Pewter 12 pcs		
26-1051-12PR	Purple 12 pcs	26-1051-144BK	Black 144 pcs
26-1051-12R	Red 12pcs	26-1051-144PR	Purple 144 pcs
26-1051-12Tn	Tan 12 pcs	26-0194-00	Orange pcs
26-1051-12PNK	Pink 12pcs	26-0568-00	White pcs
26-1051-12OLV	Olive 12pcs	26-1051-12BRN	Brown pcs
26-1051-12N	Navy 12pcs	26-1051-120P	Copper 12 pcs
26-1051-12WN	Wine 12pcs	26-1051-12EB	Electric Blue 12 pcs
26-1051-12SPR	Spruce 12pcs	26-1051-12PB	Powder Blue 12 pcs
26-1051-144B	Blue 144 pcs	26-1051-12PLM	Plum 12 pcs
26-1051-144G	Green 144 pcs	26-1051-12RB	Royal Blue 12 pcs
26-1051-144R	Red 144 pcs	26-1051-144BO	Burgandy 144 pcs
26-1051-144TN	Tan 144 pcs	26-1051-144CM	Charcoal 144 pcs



### 'Master' Billiard Chalk

- ▶ Top quality billiard chalk
- ▶ Sold in boxes of 12 or 144 pcs
- ▶ Available in red, blue or green

26-1023-12R	Red 12 pcs
26-1023-12B	Blue 12 pcs
26-1023-12BLK	Black 12 pcs
26-1023-12G	Green 12pcs



### Blue Diamond Leather Tips

- ▶ Quality Leather cue tips
- ▶ Sold in boxes of 50
- ▶ Available in blue

47-2001	9mm
47-2002	10mm
47-2003	11mm
47-2006	14mm



### Screw-on Tips

- ▶ Available with plastic M8 thread in 12mm or 10/24 brass thread with 10, 11 or 12mm tip
- ▶ Sold in bags of 100

47-1230-6	12mm plastic thread
47-1240-2	10mm brass thread
47-1240-4	11mm brass thread
47-1240-6	12mm brass thread



### Cue Tip Clamp Aluminium

- ▶ For easy replacement of cue tips
- ▶ Keeps pressure on the cue tip

47-1330	Cue tip clamp
---------	---------------



### Tip Fastener

- ▶ Keep pressure on the ferrule and tip
- ▶ Including compact file

47-1332	Tip fastener
---------	--------------



### Cue Tip Cement Tweeten

- ▶ Great for attaching leather tips to cues
- ▶ Will not harm leather tip
- ▶ Contents 2 oz / 57 grams

26-1107-00	Cement
------------	--------



### Ferrules

- ▶ Various sizes plastic or brass ferrules

47-1261-4	Brass ferrule 11mm
47-1265	Plastic ferrule M8 plastic thread



### Snooker Ball Rails

- ▶ Sold per set of 6

47-0775	Ball Rails
---------	------------





**Chrome Cue Case for 2 piece Cue**

P2231 Chrome Cue Case



**Hard Cue Case for 2 piece Cue**

47-0550 Hard Cue Case



**SoftCue Case for 2 piece Cue**

47-0549 Soft Cue Case



**Foam Tube split Cue Case**

47-0565 2 piece Cue Case



**Hard Cue Case with 2 piece Cue**

47-0273-90 2 piece Ash Cue & Case



**Rapid Cue Top Sander**

- ▶ Tool for precise preparing of the ferrule before replacing a cue tip

26-1103-00 Rue top sander



**Sand Paper**

- ▶ For use with the rapid cue top sander
- ▶ Sold per 10

47-0970-1 Sand paper



**Slip-on Rubber Bumper**

- ▶ Replacement rubber bumper
- ▶ Used on most standard pool cues

47-1320 Slip-on rubber bumper



**Screw-on Rubber Bumper**

- ▶ Replacement rubber bumper
- ▶ Screw mount (screw not included)

47-1310 Rubber bumper



**Tip Trimmer**

47-1080 Tip trimmer



**Table Brushes**

- ▶ Standard equipment for any pooltable
- ▶ Available in 23cm (9") or 30cm (12") size

47-1001-1 23cm (9") Brush

47-1001-3 30cm (12") Brush



**Table Brush The Luxe**

- ▶ 9" High quality brush

47-1002-1 9" brush The Luxe

47-1002-2 12" horsehair



**Nylon Rail Brush**

47-1010 Rail brush



**Cue Cleaner**

- ▶ Removes dirt and polishes the cue shaft

47-139 Cue cleaner



**Snooker Net**

- ▶ Bag type. Sold per set of 6

47-0765-2 Snooker net



### Essex Straight Six Pool Mech

- ▶ This coin-mechanism is very selective thickness and diameter
- ▶ Very robust and highly flexible with respect to price-of-play change

47-0721-X Straight six  
 47-0721-83 UK Industry New £1  
 47-0721-81 Europe / Euro



### Ratchet Spring and Pawl for Straight

47-0725 Spring and pawl



### SS3228 Return Spring for Straight Six

47-0725-9 Return spring old  
 47-0725-9 NEW Return spring



### Rubber Chalk Holder

- ▶ Rubber holder protects chalk from damage
- ▶ Prevents chalk from being taken away

47-1050-2 Rubber chalk holder



### Cloth Plasters

- ▶ Bag type. Sold per set of 6

47-1305 Cloth plasters



### Brass Bridge Heads

47-1030 X bridge head  
 47-1030-1 Long bridge head  
 47-1030-2 Butt  
 47-1030-3 Spider  
 47-1030-4 Brass Swan  
 47-1031 Plastic tip



### Brass Heads

- ▶ Sold without toes

P5670 X rest  
 P5671 Butt rest  
 P5672 Spider rest



### Chrome Bridge Heads

- ▶ Available as X rest or spider rest

47-1030-8 X rest chrome  
 47-1030-9 Spider rest chrome



### Black Plastic Pool Triangle

- ▶ These high-impact, durable plastic triangles are economical and well designed for proper ball racking

47-0700-1 15 balls 2-1/4"  
 47-0700-3 15 balls 2-1/16"  
 47-0700-4 15 balls 2"  
 47-0700-5 10 balls 2"



### Pool Table BatteryPack

- ▶ 15.6V non-rechargeable

E1168 Battery pack



### Magnetic Chalk Holder

47-1055 Magnetic chalk holder



### UK manufactured Dowsing Iron

- ▶ Thermostatically controlled with a temperature setting dial underneath the handle
- ▶ Supplied with a lead which is detached when ironing the table and a with a special stand on which to safely place the hot iron

47-0980



### Simonis x-1 cleaning tool

- ▶ Removes chalk and dust on cloth
- ▶ Won't stretch or damage Cloth
- ▶ Non-slip handle for control
- ▶ Curved shape allows access to cloth underneath rails

P7065



### Ball Tray

47-0710 Ball tray 16 balls  
 47-0710-1 Ball tray 22 balls



### Oak 9-Ball Diamond

- ▶ For 2-1/4" balls
- 47-0703-2 Oak 9-ball triangle



### 9-Ball Triangle

- ▶ For 2-1/4" balls
- 47-0703-1 9-ball diamond  
 47-0700-6 9-ball triangle



### Pressure Sensitive Spots

- ▶ Marking points for pool billiard
- ▶ Black textile with spot in 3 different sizes: 12, 35 and 62mm

47-1300-12 12mm spot, per 5  
 47-1300-35 35mm spot, per 5  
 47-1300-62 62mm spot, per 5



### Pool Table Cover

- ▶ For 6ft table, With fitted elastic band
- 47-0747 Table cover



### Economy Green Cover

47-0740 7 ft  
 47-0745-1 8 ft  
 47-0742 9 ft  
 47-0743 10 ft  
 P2232 12 ft

### Heavy Duty Cover, Black

47-1524 7ft Table  
 47-1525 7ft Table



### Corner Cue Stand

- ▶ Oakwood finish cue-stand
- ▶ Holds 8 cues
- ▶ Top-shelf has cork liners for ashtray and 4 glasses
- ▶ Height 60cm

47-0502 Corner Cue Stand



### Riva Cue Stand

- ▶ The low boy cue-rack, has walnut hardwood finish
- ▶ Holds 8 cues
- ▶ Height 83cm

47-0501 Riva Cue Stand



### 12 Cue Heavy Duty Metal Rack

- ▶ 18 gauge steel
- ▶ Baked on black powder coating
- ▶ Smooth rolled holes
- ▶ 24"(H) x 14"(W) x 11"(D)
- ▶ Weight 14 lbs

26-1461-00 NEW part number



### 17 Cue Metal Floor Rack

- ▶ Heavy duty - made from 1/4" steel rod
- ▶ Base - 11-3/4" x 11-3/4" Height - 24"

26-1977-00 NEW part number



### 12 Cue Metal Floor Rack

- ▶ Attractive black wrinkle powder coat metal finish with heavy duty brushed metal supports

26-1105-00 NEW part number



### Pro-Wheeler Cue Rack

- ▶ Plastic Cue Rack for 6 Cues

47-0505-3 Pro Wheeler Cue Rack



### Cue-Rack

- ▶ Wooden cue-rack for 4, 6, or 8 cues
- ▶ Solid construction with black flexible plastic cue clips
- ▶ Can be mounted to hold cues at centre up to 12" below tip

47-0507 6 Cue - rack  
47-0507-1 4 Cue - rack  
47-0507-2 8 Cue - rack



### Black 2 piece Cue Rack

- ▶ Holds 6 cues

47-0509 Cue Rack



### Cue Clip

- ▶ Black cue clip holds cues without marring

47-1385-1 Plastic cue Clip



### 2"-50.8mm Pool Ball Sets 1-7/8"-48mm cue ball

- 47-0822 2" Spots and stripes
- 47-0842-1 2" Reds and yellows
- 47-0842-BY 2" Blues and yellows



### Snooker Ball Sets

- 47-0893 2-1/16" 22 balls
- 47-0842-Sn 2" 17 balls



### Pool Balls 2"-50.8mm

- 47-0802-2 Red ball 2"
- 47-0802-4 Yellow ball 2"

### 2-1/4"-57mm Crazy 8 Ball

- ▶ Never follow the desired direction

47-0090 Crazy 8 ball

### Cue Balls

- 47-0801-9 1-7/8"
- 47-0802-9 2"
- 47-0804-9 2-1/8"
- 47-0805-9 2-1/4"
- 47-0806-9 2-3/8"

### 2-1/4"- 57mm PoolBall Sets Spots and Stripes

47-0845 2-1/4" with cue ball



### 2-1/4"- 57mm Pool Ball Sets Reds and Yellows

47-0845-1 2-1/4"-with cue ball



### 8 Balls

- 47-0812-8 8 Ball 2"
- 47-0815-8 8 Ball 2-1/4"



### Pool Magnetic Cue Ball

- ▶ Used in various pooltable brands like Valley and others

47-0807-9 Magnetic



# Table Lighting

## Billiard Lamp "Nostalgia"

- ▶ These decorative 3-pieces billiard lamps are available with a brass or chrome bar and fittings. Mounting hardware included
- ▶ Available in the following colours: red, green, blue, brass and chrome
- ▶ Overall length approx. 120cm
- ▶ Fittings are for use with bayonet lamps (not included)
- ▶ Shades and bars are supplied separately

- P5654 3-way brass bar and fittings
- P5663 3-way chrome bar and fittings
- 47-0030-2 Red bowl shade
- 47-0030-5 Green bowl shade
- 47-0030-6 Blue bowl shade
- 47-0030-C Chrome bowl shade
- P2220 Brass bowl shade
- 47-1480-1 Chain (gold)



# Rules & Scoreboards



P4001 Notice Board, Superleague Pool



Pool Rules



P408 Pool Knockout Sheet (Pk 10)



Scoreboard for 2 Players  
47-0603 Scoreboard



Scoreboard for 4 Players  
P2250 Scoreboard

# Refurb Accessories

## Pool Refurb Kit

- ▶ 1 set Bed & Cushions 7x4 (Red, Green or Blue)
- ▶ 1 set balls (R&Y or B&Y)
- ▶ 1 Box Chalk (Red, Green or Blue)
- ▶ 1 12" Brush
- ▶ 1 Cloth Cleaner
- ▶ 1 Cloth Adhesive
- ▶ 1 Plastic Triangle for 2" balls
- ▶ 1 Pool Rules Sheet

REFURB-KIT-RED  
REFURB-KIT-BLUE  
REFURB-KIT-GREEN



## Rubber Cushion

- ▶ Moulded pure gum rubber
- ▶ Sold in set of 6 pcs
- ▶ With linen protector
- ▶ Responsive cushion - attracts players



47-0761 Rubber 48" - 122cm

## Economy L Shaped Rubber

- ▶ 183cm (72") length. Pink

47-0764 L shaped rubber pink



## Club L Shaped Rubber

- ▶ 183cm (72") length. Black

47-0764B L shaped rubber black



## Pocket Liner for Pool Table

- ▶ Colour black
- ▶ 6 pcs per set
- ▶ 4 corners and 2 sides
- ▶ Available in rubber and vinyl, 3 and 4"



47-075 3" (rubber)  
47-0750-1 4" (rubber)  
47-0750-2 4" (vinyl)

## Gulley Boots

- ▶ Used for pool billiard
- ▶ Colour black
- ▶ 6 pcs per set

47-0756 Gulley boots



## Paste on Pool Table Adhesive

- ▶ Available in 1 and 5 litre tubs

E9787 1 litre tub  
E9786 5 litre tub



## Pool and Snooker Cloth Cleaner

- ▶ Removes chalk and light contamination from snooker and pool table cloth

▶ Contents: 400 ml

20-008 Cloth Cleaner



## Pool and Snooker Cloth Adhesive

- ▶ High strength adhesive with longer open bond time for large surface areas

▶ Tack time: 2-10 minutes

▶ Contents: 500 ml

▶ Ambersil HS300

20-0100 HS 300

20-0082 NC 500

20-0075 QS 900



## D Marker

P5055 D Marker



## Pocket Liner Screw

- ▶ Sold in packs of 50

P1139 1 Screw



## Pool Table Marker Pen

47-0700c Marker Pen



## Hydro Trolley

- ▶ Hydraulic
- ▶ Pool Table Trolley
- ▶ Maximum lifting weight 600 Kg

P7999



## Piano Trolley

- ▶ Maximum lifting weight 600 Kg

P0142



## Hydraulic Lifting Table

- ▶ Rugged construction
- ▶ Polyester powder coated hammer grey
- ▶ Large wheels for easy manoeuvrability under load
- ▶ Foot pedal operation
- ▶ Non-removable handle
- ▶ Unladen weight 26Kg

P7501

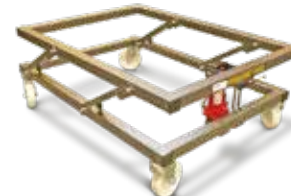

## Aerosols

A dry graphite lubricant for long lasting, smooth lock operation. The microscopic grains of graphite ensure good penetration and effective anti-seize lubrication.

- ▶ Long lasting lubrication
- ▶ Dry film does not attract dirt and grime
- ▶ Excellent water resistance
- ▶ Wide operating temperature range
- ▶ Works even when lock has mild corrosion

NEW



Many More Ambersil Products Available

# Take advantage of our on-site cloth cutting service ANY CLOTH! ANY COLOUR! ANY SIZE!



## Strachan



The Strachan range of fine billiard and snooker cloths offer products of the highest quality, providing players with the ultimate high performance playing surface characterised by a crisp, highly engineered nap with a lustrous finish, consistent colour and high durability.

### Snooker Cloth 100% wool

1032-GR	number 10 Championship cloth 1 meter 30 oz
P5965-Sn	Full Size number 10 Bed and Cushion
6811GO-GR76 6811	(Tournament) 1 meter. 30oz
6811-Sn	GO Full Size Snooker Gold bed & Cushion pack
6811-Sn	GOB Full Size Snooker Gold bed only
6811-Sn	GOC Full Size Snooker Gold cushion only
10X5PK6811	GOSn 6811 Gold 10 foot Snooker
9X5PK6811	GOSn 6811 Gold 9 foot Snooker

Also available in other lengths

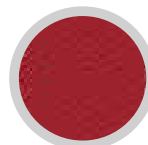

05. New Red

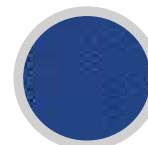

06. English Bue

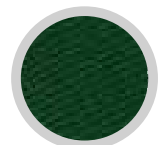

12. Olive

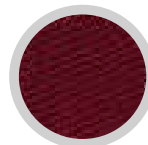

17. Burgundy

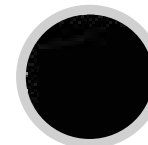

20. Black



52. Purple

### 6811 Pool Cloth - CLUB

- ▶ 100% wool
- ▶ With Spillguard
- ▶ Weight 29oz @ 86"

6811-GR86	6811 Pool Green cloth 1 meter 86"
6811-BL86	6811 Pool Blue cloth 1 meter 86"
6811-Bu86	6811 Pool Burgundy cloth 1 meter 86"
6811-RE86	6811 Pool Red cloth 1 meter 86"
6811-BLK86	6811 Pool Black cloth 1 meter 86"

Available in 6x3, 7x4, 8x5, 9x5 cut packs  
Part number = XXXPACK6811YYY

### 6811 Pool Cloth - TOURNAMENT

- ▶ 100% wool
- ▶ With Spillguard
- ▶ Weight 29oz @ 86"

6811GO-GR86	6811 Pool Green cloth 1 meter 86"
6811GO-BL86	6811 Pool Blue cloth 1 meter 86"
6811GO-Bu86	6811 Pool Burgundy cloth 1 meter 86"
6811GO-RE86	6811 Pool Red cloth 1 meter 86"
6811GO-BLK86	6811 Pool Black cloth 1 meter 86"

Available in 6x3, 7x4, 8x5, 9x5 cut packs  
Part number = XXXPACK6811YYY

### 6811 Tournament Cloth

- ▶ 100% wool
- ▶ With Spillguard
- ▶ Tournament cloth available in 63"
- ▶ Weight 14.5 oz

6811-GR63	6811 Gold 63" 1 meter Green
6811-BL63	6811 Gold 63" 1 meter Blue
6811-Bu63	6811 Gold 63" 1 meter Burgundy
6811-RE63	6811 Gold 63" 1 meter Red
6811-Pu63	6811 Gold 63" 1 meter Purple
6811-BK63	6811 Gold 63" 1 meter Black

Available in cut packs

777-GR85	777 85" Green
777-BL85	777 85" Blue
777-PuR85	777 85" Purple
777-RE85	777 85" Red
777-BLK85	777 85" Black
777-BuR85	777 85" Burgundy

All of above available in 6x3, 7x4, 8x5, 9x5 cut packs  
Part number 777-XXX-YY  
(XXX= pack size 6x3, 7x4, 8x5 or 9x5 -YY= Colour code)

### Eurospeed Billiard Speed Cloth

- ▶ Weight 630gr per running meter
  - ▶ Width 63" ( also 79" available for English green only )
  - ▶ 45% wool 65% nylon
  - ▶ Offering to our customers a good quality range of spee cloth at an excellent price
  - ▶ Sold per meter or pre-cut packs for 6x3, 7x4, 8x5 or 9x5 Packs
- Part numbers PXXXX-YYY  
(PXXXX = Cloth part no YYY = pack size, for example 6x3)

Part numbers	Colour
P5093	Eurospeed yellow green 63" - 1mtr
P5094	Eurospeed powder blue 63" - 1mtr
P5095	Eurospeed purple 63" - 1mtr
P5096	Eurospeed royal blue 63" - 1mtr
P5097	Eurospeed English green 63" - wide
P5098	Eurospeed red 63" - 1mtr
P5099	Eurospeed burgundy 63" - 1mtr
P5100	Eurospeed US blue green 63" - 1mtr
P5101	Eurospeed black 63" - 1mtr
P5097-200	Eurospeed English green 79" - wide

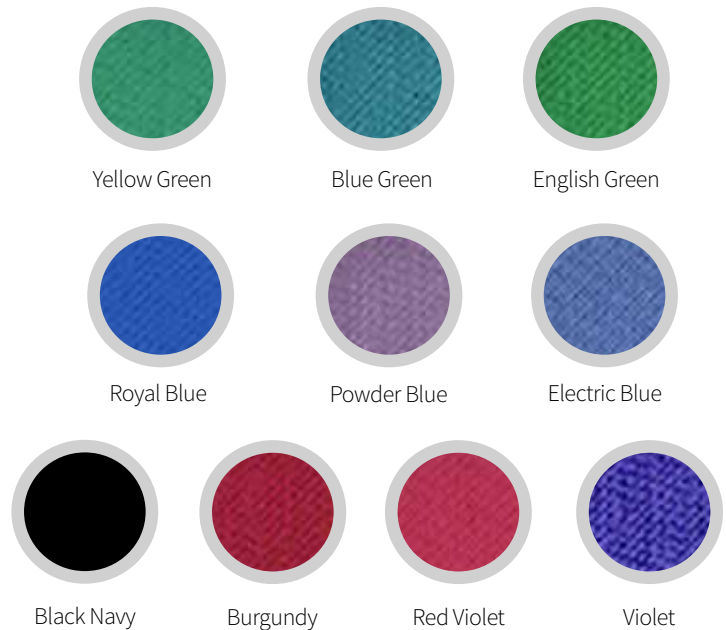

### SuperPro Speed Cloth

- ▶ Speed Cloth
- ▶ Spillguard finish
- ▶ 30% nylon / 70% Wool
- ▶ Supplied in 78" width in a variety of colours
- ▶ Sold per meter or cut packs
- ▶ Cut Packs Sold in 6x3, 7x4, 8x5 and 9x5

Part number = SPRO-XXX-YY  
(XXX= pack size 6x3,7x4,8x5 or 9x5 - YY= Colour code)

Part numbers	Colour
SPRO-BLK78	Black
SPRO-BL78	Blue
SPRO-Bu78	Burgundy
SPRO-EB78	Electric Blue
SPRO-TB78	Tournament Blue
SPRO-GR78	Green
SPRO-YG78	American Yellow Green
SPRO-BG78	American Blue Green
SPRO-RE78	Red
SPRO-Pu78 29.75	Purple
SPRO-CAM78 29.75	Tan/Camel



## Artscape™

ArtScape™ is high definition, digital imaging onto premium grade, spill protected pool table cloths

Using our expertise and leading edge technologies we print unique, photo realistic designs coordinated across the bed and cushion rails. ArtScape™ imaging is available on cloth made for both American and English pool. All our fabrics are manufactured to the highest quality and durability.

We have over 100 years experience in the manufacture of pool and snooker cloths. We possess the unique ability to process the printed cloth through our finishing technology to achieve the perfect playing surface whether this is a fine worsted or a fine napped finish.

ArtScape pool cloths can increase table revenue by up to 40% and offer the complete solution; each is made to measure, individually packaged and easy to fit.

Our designs do not affect cloth performance or play characteristics and maintain cloth appearance for longer by minimising the effects of wear.

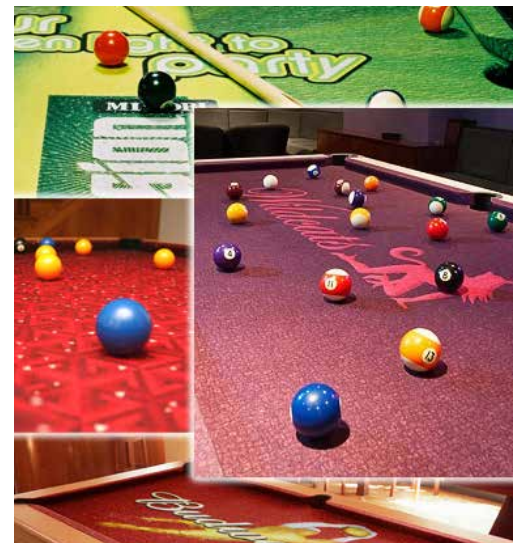

## Pool & Snooker Balls

Saluc produces and distributes billiard balls under the registered trademark Aramith in more than 85 countries, and has a market share of 80% worldwide. The company is also specialised in the production of industrial balls used in all kind of applications, as well as in 9 pin bowling balls and trackballs. Export represents 98% of its activity.

One of the major strengths of the company is its upstream integration: Saluc has its own chemical plant, which produces the phenolic resin which gives the exceptional characteristics to the finished products. This integration allows the price optimization and quality insurance. The Aramith phenolic balls last up to five times longer than other balls made of polyester," said Yves Bilquin, sales and marketing manager for north America and previously the R&D manager. SUZOHAPP is a distributor and stockist of Aramith products, the full range is available although some of the less standard items may require lead times and stock.



47-0100	Aramith Crazy Cue ball 2-1/4"
47-0108	Sapro Striped 8 Ball
47-0809	Aramith 2" Cue Ball Premier
47-0098	Aramith micro fibre cloth
47-0099	Aramith 2-1/4" TV Spots and stripes
47-0610	Aramith 2 1/4" S & S Premium
47-0610-1	Aramith 1-7/8 S&S Premier
47-0610-2	Aramith 2-1/16 S&S Premier
47-0611	Aramith 2" 1-7/8 S & S Premium
47-0613	Aramith 2" 1-7/8 S & S Standard
47-0611-1	Aramith 2" R & Y 1-7/8" Premium
47-0613-1	Aramith 2" R & Y 1-7/8" Standard
47-0611-2	Aramith 2" B & Y 1-7/8" Premium
47-0611-3	Aramith 1-7/8 R-Y Premier
47-0615-8	Aramith 2" Black Ball no.8
47-0616-8	Aramith 2 1/4" Black Ball no.8
47-0616-9	Aramith 1 7/8" Cue Ball white Premier
47-0617-9	Aramith 2 3/8" Cue Ball white Premier
47-0618-9	Aramith 2 1/4" Cue Ball white Premier
47-0619-9	Aramith 2 1/16" Cue Ball Premier
47-0620-1	Aramith 2 1/16" snooker set
47-0620-2	Aramith 2"+ 1-7/8" snooker set
47-0620-3	Aramith 2" 17 Ball snooker set

47-0620-4	Aramith 2-1/4" 22 Ball snooker
47-0620-5	Aramith 1-7/8" 17 Ball snooker
47-0620-6	Aramith 1-1/2" 17 Ball Snooker
47-2010	Aramith 1-3/4" 17 Ball Snooker
47-0620-9	Aramith magnetic 2 1/4" Cue Ball
47-0630-1	Aramith 2-1/4" Granite set
47-0630-3	Aramith 2-1/4" Red logo Cue Bal
47-0630-7	Aramith bar billiard set 1-7/8
47-2007	2-1/16" Tournament Championship snooker set
47-2008	STC 2-1/16" R/Y/W Billiard
47-2009	Sapro R&Y with Striped 8 ball set
47-2009-1	Sapro Cup R & Y 2" nylon case set
47-0088	Aramith super 2-1/4" pro-cup
47-0089	Aramith Golden 8 Ball
47-0090	Aramith Crazy 8 Ball
47-0091	Aramith Ball cleaner
47-0092	Aramith Ball restorer
47-0093	Aramith 1-7/8" Pro cup Cue Ball Premier
47-0096	Aramith 2-1/16" Pro cup Cue Ball Premier
47-0097	Aramith 2-1/4" Pro cup Cue Ball Premier
47-2011	Aramith Tournament Champion 2-1/16" Cue ball
47-2012	Aramith Glow-in-the Dark 2" Home Kit
47-2013	Aramith Glow-in-the Dark 2-1/4" Home Kit





SUZOHAPP

# CONTACT US

## NORTH, CENTRAL, & SOUTH AMERICA

### CANADA

**SUZOHAPP Canada**  
587 Hanlan Road  
Woodbridge, ON L4L 4R8  
Local Phone: +1 905-851-9775  
Tool free: +1 800-239-7017  
Tech. Support: +1 847-593-6161 Ext 7733  
@ bill-to-bill@suzohapp.com

### USA

**SUZOHAPP Americas**  
1743 Linneman Rd  
Mount Prospect, IL 60056  
Toll Free: +1 888-289-4277  
Local Phone: +1 847-593-6130  
Toll Fax: +1 800-593-4277  
Local Fax: +1 847-593-6137  
@ info@suzohapp.com

**SUZOHAPP Americas**  
1385 Pama Lane Unit 100  
Las Vegas, NV 89119  
Toll Free: +1 888-289-4277  
Gaming Tech Support: +1 702-588-5365  
Non-Gaming Tech Support:  
+1 847-593-6161 Ext 7124  
Toll Free Fax: +1 877-870-2259  
Local Fax: +1 702-597-4837  
@ info@suzohapp.com

**SUZOHAPP Americas**  
7745 Carondelet Ave., Suite 300  
Clayton, MO 63105  
+1 847-593-6161  
+1 800-593-4277  
@ info@suzohapp.com

## EUROPE, MIDDLE EAST, AFRICA

### BELGIUM

**SCAN COIN Belgium sa**  
De Vunt 13 b 18  
B-3220 Holsbeek  
+32 16 296 073  
@ info.hb.be@suzohapp.com

### DENMARK

**SCAN COIN A/S**  
Smedeland 6  
DK-2600 Glostrup  
+45 43 63 06 44  
+45 43 43 27 28  
@ info.gl.dk@suzohapp.com

### FRANCE

**SUZOHAPP France SAS**  
8 Avenue de l'Île Saint-Martin  
92000 Nanterre  
+33 1 56 05 28 00  
@ sales.fr@suzohapp.com

### GERMANY

**SUZOHAPP Germany GmbH**  
Hamburger Str. 11  
22083 Hamburg  
+49 40 54 76 130  
+49 40 54 76 1330  
@ sales.de@suzohapp.com

### IRELAND

**SCAN COIN Ireland Ltd.**  
Bracetown Business Park  
Clonee, Dublin 15 D15 DH2N  
+353 1 8014077  
+353 1 8014129  
@ sales@scancoin.ie

### ITALY

**Comestero Group S.r.l.**  
Centro Direzionale Cassina Plaza  
Via Roma 108, Edificio F scala 1  
20060 Cassina de' Pecchi (MI)  
+39 02 87 17 66 78  
+39 02 95 38 01 78  
@ sales.it@suzohapp.com

### NORWAY

**SCAN COIN AS**  
Rosenholmsveien 20  
NO-1252 Oslo  
+47 66 81 34 00  
+47 23 382 939  
@ info.os.no@suzohapp.com

### POLAND

**SUZOHAPP Polska Sp. z o.o**  
Składowa 1B, Koninko  
62-023 Gądkki k. Poznania  
+48 61 271 6060  
+48 61 271 6061  
@ info.pl@suzohapp.com

### SPAIN

**SUZOHAPP Spain S.A.**  
Avenida Pirineos, nr. 7 Interior, nave B2  
28703 San Sebastián de los Reyes  
Madrid  
+34 916 611 818  
+34 902 446 777  
@ sales.es@suzohapp.com

Avenida de Cornellà, n. 142  
Planta 1ª Edificio Lekla  
08950 Esplugues de Llobregat - Barcelona  
+34 934 802 878  
+34 902 446 777  
@ sales.es@suzohapp.com

### SWEDEN

**SCAN COIN AB**  
Nordenskiöldsgatan 24  
211 19 Malmö  
+46 40 6000 600  
@ info.se@suzohapp.com

**SCAN COIN Intramat AB**  
Marinvägen 5  
SE-471 41 Rönnäng  
+46 40 600 06 00  
@ order.intramat@scancoin.com  
@ support.intramat@scancoin.com

### SWITZERLAND

**SUZOHAPP Switzerland SA**  
Route de Pra de Plan 17  
CH-1618 Châtel-St-Denis  
+41 21 905 36 95  
+41 21 905 44 12  
@ info.cd.ch@suzohapp.com

### THE NETHERLANDS

**SUZOHAPP Netherlands B.V.**  
Rijnzathe 12  
3454 PV De Meern  
+31 (0)186 643333  
@ sales.nl@suzohapp.com

### UNITED KINGDOM

**SUZOHAPP (UK) Ltd**  
Units 1 & 2, King Georges Trading Estate  
Davis Road, Chessington,  
Surrey KT9 1TT  
+44 208 391 7700  
+44 208 391 7760  
@ sales.uk@suzohapp.com

Dutch House, 110 Broadway  
Salford Quays,  
Salford M50 2UW  
+44 161 873 0505  
+44 161 873 0501  
@ sales@scancoin.co.uk

**SCAN COIN Technology Ltd**  
22, Stafford Park, 12  
TF33BJ Telford  
+44 1952 200 636  
+44 1952 290 018

## ASIA, PACIFIC, AUSTRALIA

### AUSTRALIA

**SUZOHAPP Australia Pty Ltd**  
44-48 Rocco Drive, Scoresby,  
Victoria 3179  
+61 3 9757 5000  
Free Call: +61 1300 00 7896  
+61 3 9763 7265  
@ info@suzohapp.com.au

### CHINA

**SUZOHAPP Asia Limited, Macau**  
Avenida Venceslau de Morais no. 157  
Kek Seng Industrial Building  
Phase 2, 2nd Floor-L  
Macau  
+853 2895 6289  
+853 2843 7019  
@ info@suzohappasia.com.mo

**SUZOHAPP China Limited  
Shenzhen branch**  
Room 5405, Chun Hing Square  
Diwang Commercial Center, Luohu District  
Shenzhen  
+86 0755 2512 3746  
@ info.ko.hk@suzohapp.com

**SUZOHAPP China Factory  
Zhuhai Factory**  
3 Airport North Rd, Sanzao  
Jinwan District, Zhuhai, 519040  
+86 7567511630  
+86 756 7511283  
@ info.ko.hk@suzohapp.com

**SUZOHAPP Hong Kong Limited**  
Unit B, 3/F, Dragon Industrial Building,  
93 King Lam Street, Lai Chi Kok, Kowloon  
Hong Kong  
+852 25906438  
+852 2590 6423  
@ info.ko.hk@suzohapp.com

**Coin Acceptors (Suzhou) Co., Ltd.**  
401, Block D, No. 5 Xinghan Street, Suzhou  
+86 512 67613283  
+86 512 67613279

### INDIA

**SUZOHAPP India**  
803, Lodha Supremus, Road no. 22  
Wagle Estate,  
Thane (West), 400604  
Mumbai - Maharashtra  
+91 22-25833388/99

© 2019 SUZOHAPP.

All rights reserved. Specifications subject to change.28-Nov-19

Trademarks owned by their respective holders.

No part of this catalogue may be reproduced in any form by print, photoprint or any other means, without written permission from the publisher.

Technical data, text and pictures are subject to error and modifications.

The catalogue can be subject to further developments.

## OUR BRANDS



## OUR PARTNERS

