



USB Charger

Model: 126-0070



Manual

Version 1.4 / August 2017

Index

1. Introduction	3
2. Power supply	3
3. Features and specs	3
4. Dimensions	4
5. Installation	5

1. Introduction

Congratulations with the purchase of your slot hole mounting USB Charger. This charger is compatible with all common smartphones. It is capable of fast charging iPhones and iPads.

2. Power supply

Connect a 12V-24V DC power supply to the USB charger using the Molex Mini-Fit connector.

PIN	COLOUR	FUNCTION
1	GREEN	+12V DC / +24V DC
4	BLACK	GROUND

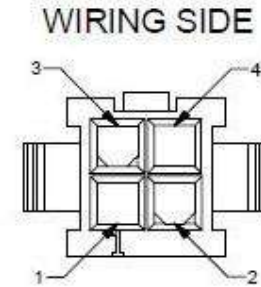

3. Features and specs

- Optimized for iPad, iPhone, iPod - fast charging at full speed
- Compatible with other smartphones
- LED power indication
- Short circuit / overheat protection
- Input: DC 12-24V (Dual Voltage)
- Output: DC 5V 1.55A Max
- USB Charger mechanically able to handle up to 30 Kg of weight
- Standard insertion force range on USB connector (3.57 Kgf MAX)
- Standard withdrawal force range (1.02 Kgf MIN)
- Durability cycle: 1500 cycles

4. Dimensions

DIMENSIONS ARE IN MILLIMETERS

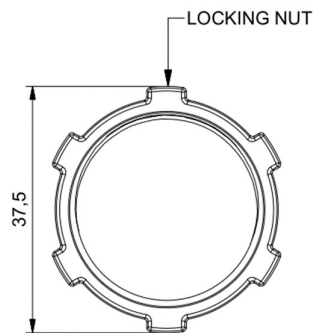
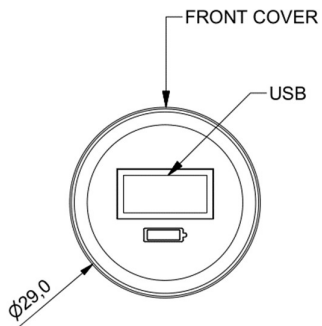
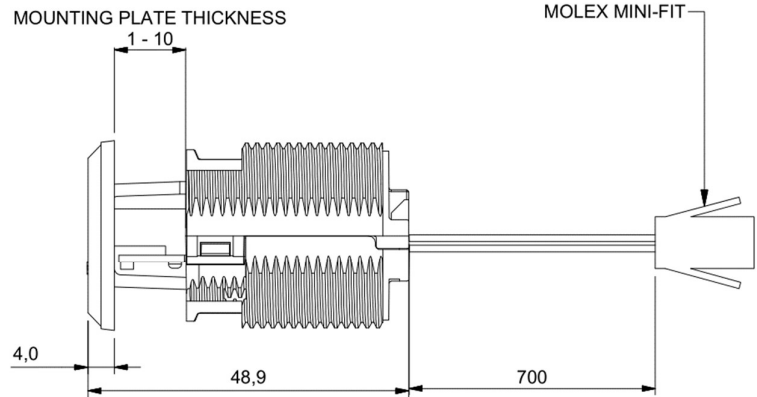
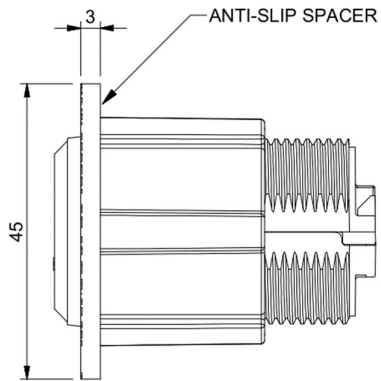
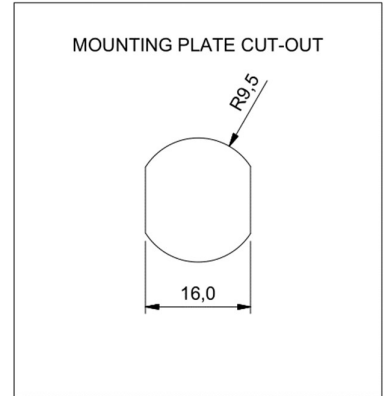
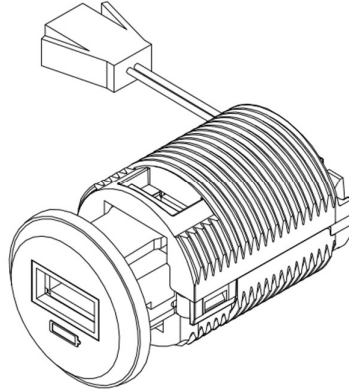
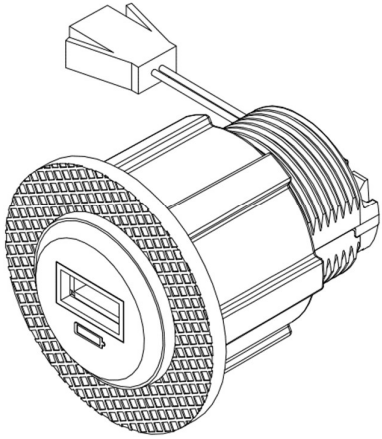

5. Installation

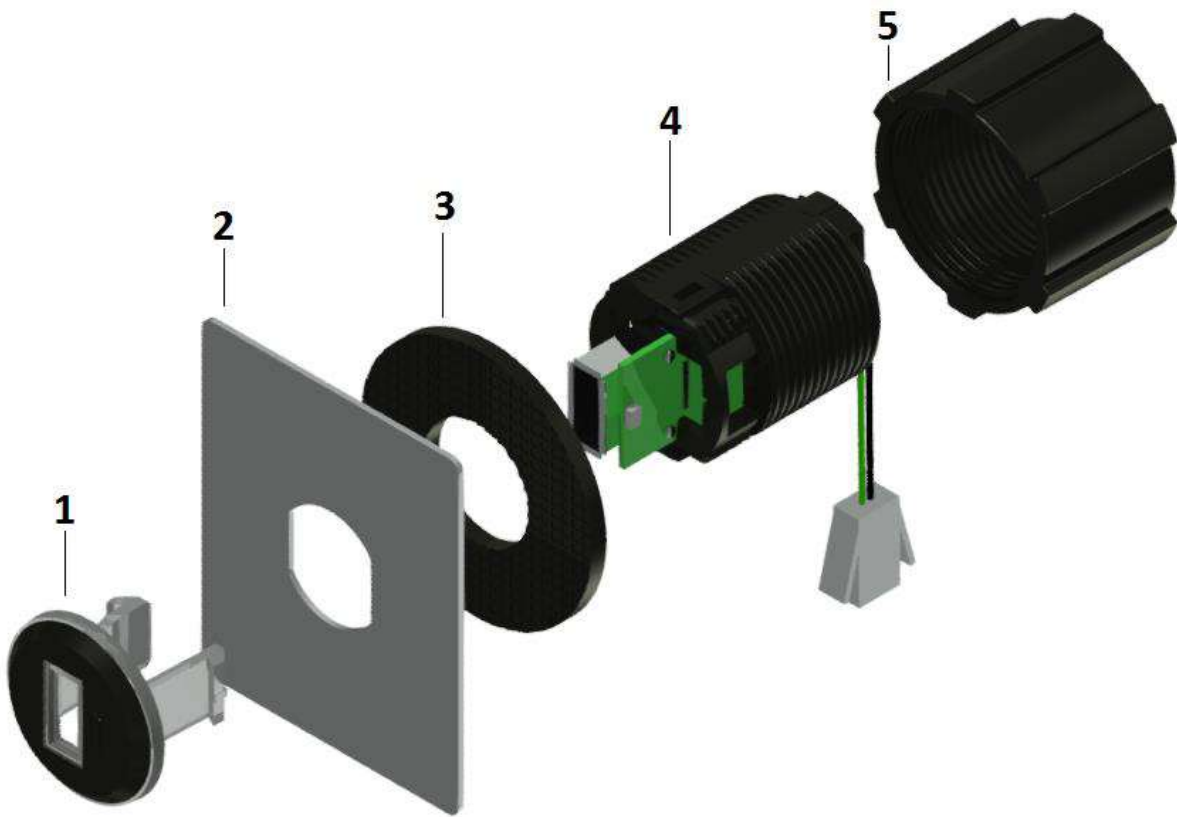

1. Cover with snappers
2. Cabinet with slot hole*
3. Rubber anti-slip spacer
4. Housing with PCB
5. Locking nut

** Your cabinet may look different. This version is only to illustrate the installation.*

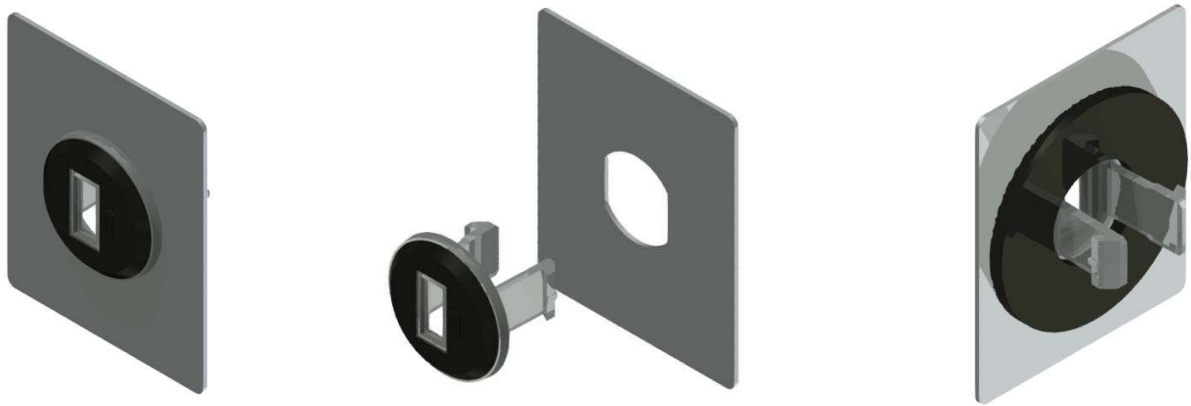

1. Stick the cover through the slot hole in the cabinet. Notice the position of the charging symbol on the cover and the lip on one side of the snapper. The other side of the snapper is wider.
2. Place the rubber anti-slip spacer on the backside.

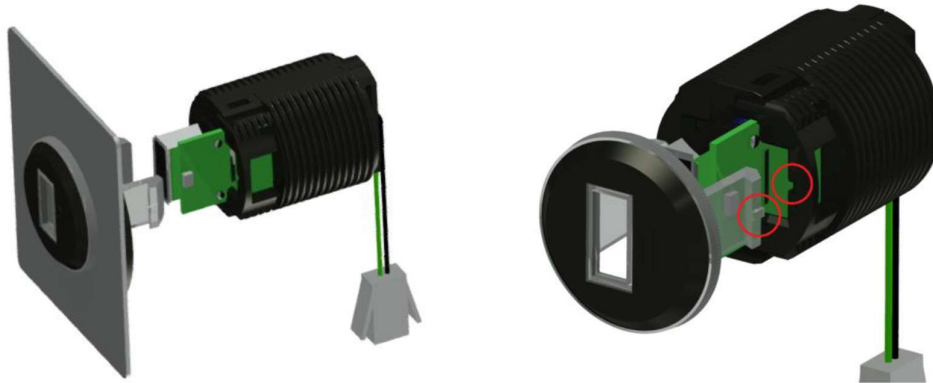

3. Move the housing with the PCB in a straight line towards the snappers of the cover. Align the housing side with the groove to the snapper with the lip.

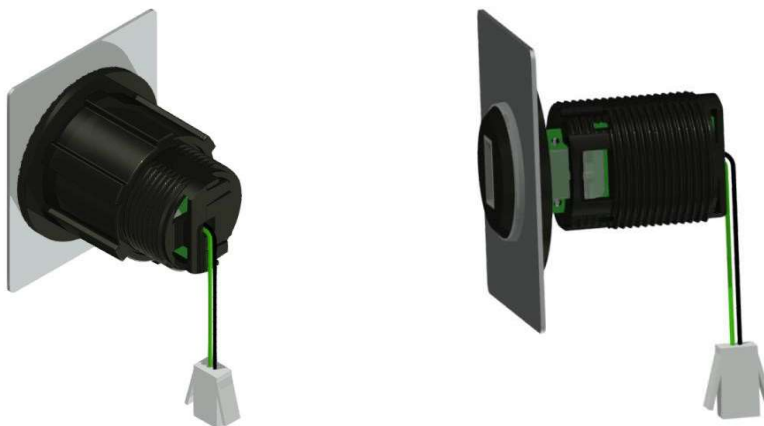

4. Gently push the snappers inwards and slide the housing onto the snappers. Because of a tight fitting, some force by hand is needed to fully snap both snappers into the housing.
5. Finish the assembly by carefully tightening the nut onto the housing towards the rubber anti-slip spacer. Do no overtighten the nut, use two fingers only.



EMA Headquarters

Antonie van Leeuwenhoekstraat 9
3261LT Oud-Bijerland The Netherlands
P +31 (0) 186 643333
F +31 (0) 186 643322
Info.nl@suzohapp.com

NCS Headquarters

1743 Linneman Rd
Mount Prospect IL 60056 USA
P +1 (847) 593 6130
F +1 (800) 593 4277
info@suzohapp.com

APA Headquarters

44-48 Rocco Drive, Scoresby
Victoria Australia 3179
P +61 3 9757 5000
F +61 3 9763 7265
info@suzohapp.com.au

suzohapp.com

For more information:

SuzoHapp Netherlands B.V.

Antonie Van Leeuwenhoekstraat 9
3261 LT Oud-Beijerland - The Netherlands
Phone: (+31) 186 64 33 33 - Fax: (+31) 186 64 33 32
sales.nl@suzohapp.com