



Topper

Product Manual

Version 1.3 / Jan. 2013



Ellipse



Ringo



Mini Ellipse



Shield (old model 104-04890)

Revision History

Revision	Date	Comment	By
0.1	3 Oct2005	Initial Release	R.T.
0.2	25 Oct2005	Number modifications	E.S.
0.3	21 March 2006	Update Mini Ellipse + New parts	E.S.
0.4	09Nov2007	More drawings	E.S.
1.0	18 Nov 2009	Delete optional sync board	E.S.
1.1	23 March 211 O	Update lamp number	E.S.
1.2	10 July 2012	Overall	E.S.
1.3	14 Jan 2013	Frontplate	E.S.

This manual is intended only to assist the reader in the use of this product and therefore Suzo International shall not be held liable for any loss or damage whatsoever arising from the use of any information or particulars in, or any omission from this manual or any incorrect use of the product.

Design and specifications are subject to change without notice.

Wijzigingen in ontwerp en technische gegevens voorbehouden, zonder kennisgeving.

La conception et les spécifications sont modifiables sans préavis.

El diseño y especificaciones están sujetos a cambios sin previo aviso.

WARNING!

Failure to observe the interface requirements specified in this technical manual may result in damage to the electronics.

Contents

1. Introduction	4
2. Safety Note	4
3. General Description	4
3.1 Description	4
3.2 Display Patterns	4
3.3 Intensity control	4
3.4 Pattern led's always off	5
3.5 Pattern led's always on	5
3.5 Topper Model options	6
3.6 Topper Base options	9
3.7 Topper Base dimensions	10
4. Installation	12
4.1 Connection	12
5. Technical specifications	12
5.1 Electrical ratings	12
5.2 Lamp	12
5.3 Schematic diagram	13

1. Introduction

The Suzo-Happ group has now introduced some new topper designs.

These units can be put on top of gaming machines as a people attraction device or to promote certain gaming machines.

2. Safety Note

To meet the requirements for EN 60950 the equipment must be installed according to the following requirements: The equipment must be protected by a 2A fuse.

The equipment must be supplied from a SELV limited power source.

The equipment must be installed in an enclosure but positioned so that it is external to any fire enclosure area within the main enclosure.

3. General Description

3.1 Description

The topper ring consists of 32 individually controlled white led's, grouped in four banks of 8 led's.

Only after power up (V1.2 and up):

After power up, the upper half of the led's show the software revision number.

Software version: Upper left 8 led's: Major version, Upper right 8 led's: Minor version

3.2 Display Patterns

The standard software version displays the following sequence of patterns:

Continuous repeating pattern sequence:

1. Pause
2. Snake
3. Pause
4. Train
5. Pause
6. Stars
7. Pause
- 8. Mill**

3.3 Intensity control

The intensity can be controlled by the small push button on the board (Software V1.2 and up).

Pressing the button once shows the current intensity level on the upper left 8 leds.

Pressing it again increases the intensity level one step. Pressing beyond it's maximum level, the mode in which the leds are always off or on is entered. See next sections.

3.4 Pattern led's always off

Since V1.5 the topper led's can be turned off continuously. Click the intensity button beyond its maximum intensity until led 12 will lit.

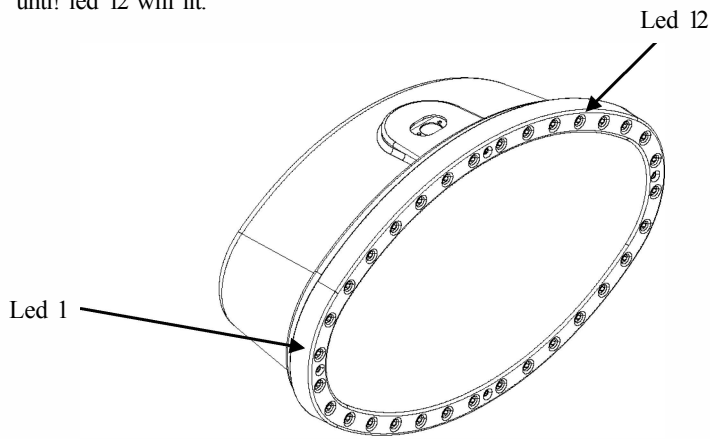

Fig. 1 Led positions for leds always off

Wait 5 seconds until the intensity setting finishes.

All led's will be off now.

By pressing the intensity button once again, then after 5 seconds normal pattern operation will continue.

3.5 Pattern led's always on

Since V1.5 the topper led's can be turned on continuously. Click the intensity button beyond its maximum intensity until led 14 will lit.

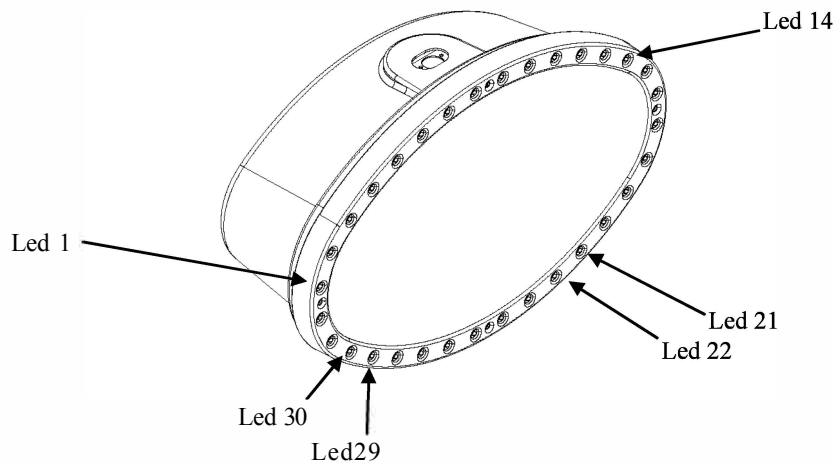

Fig. 2 Led positions for led's always on

Led 21 and led 22 will also lit. After 5 seconds all led's will turn on at minimum intensity. The intensity can be changed by clicking the intensity button maximum 7 times on which the maximum intensity level is reached. Turning off this mode is done by clicking the intensity button until led 14 will lit. Now press another time to switch to Led 29 and 30 on. This indicates that after 5 seconds normal pattern operation will resume.

3.5 Topper Model options

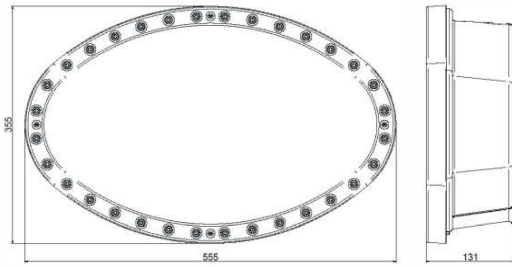

Figure 1: Ellipse Compact model

Order numbers Ellipse Compact models

Chrome: 104-05890 (default model)
 Black Chrome: 104-00070 (optional adaption kit)
 Gold: 104-0070-4 (optional adaption kit)

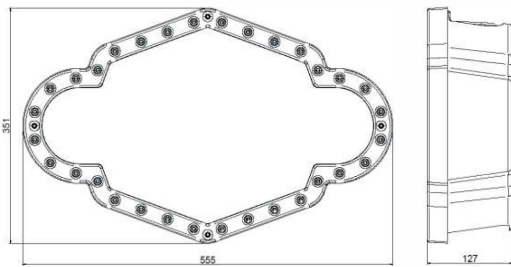

Figure 2: Ringo Compact model

Order numbers Ringo Compact models

Chrome: 104-03890 (default model)
 Black Chrome: 104-0071 (optional adaption kit)
 Gold: 104-0071-4 (optional adaption kit)

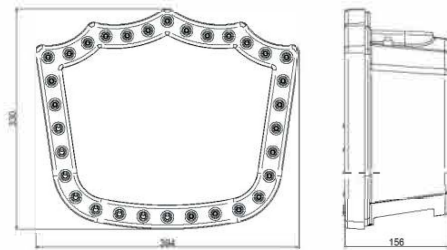

Figure 3: Shield model

Order numbers Shield models

Chrome: 104-04890 (old model)
 New model see manual 104-4891
 Black Chrome: 104-0072 (optional adaption kit)
 Gold: 104-0072-4 (optional adaption kit)

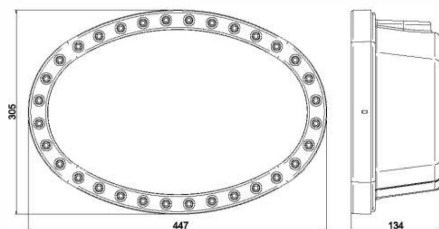

Figure 4: Ellipse Mini model

Order numbers Ellipse Mini models

Chrome: 104-06890 (default model)
 Black Chrome: 104-0073 (optional adaption kit)
 Gold: 104-0073-4 (optional adaption kit)

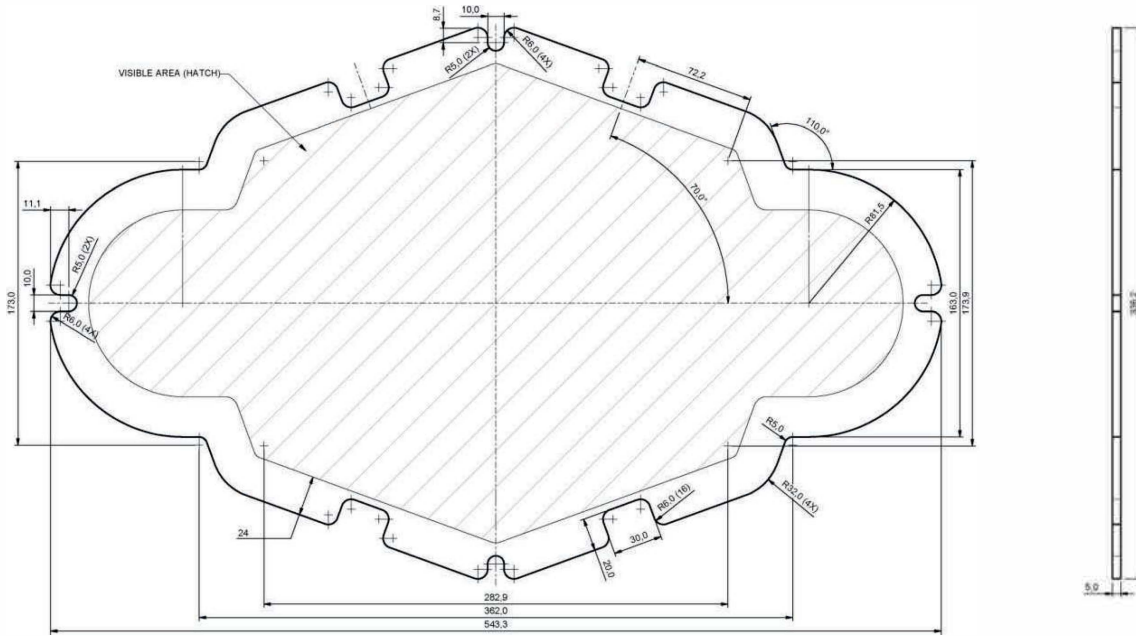

Figure 5: Front plate Ringo Compact (104-0101)

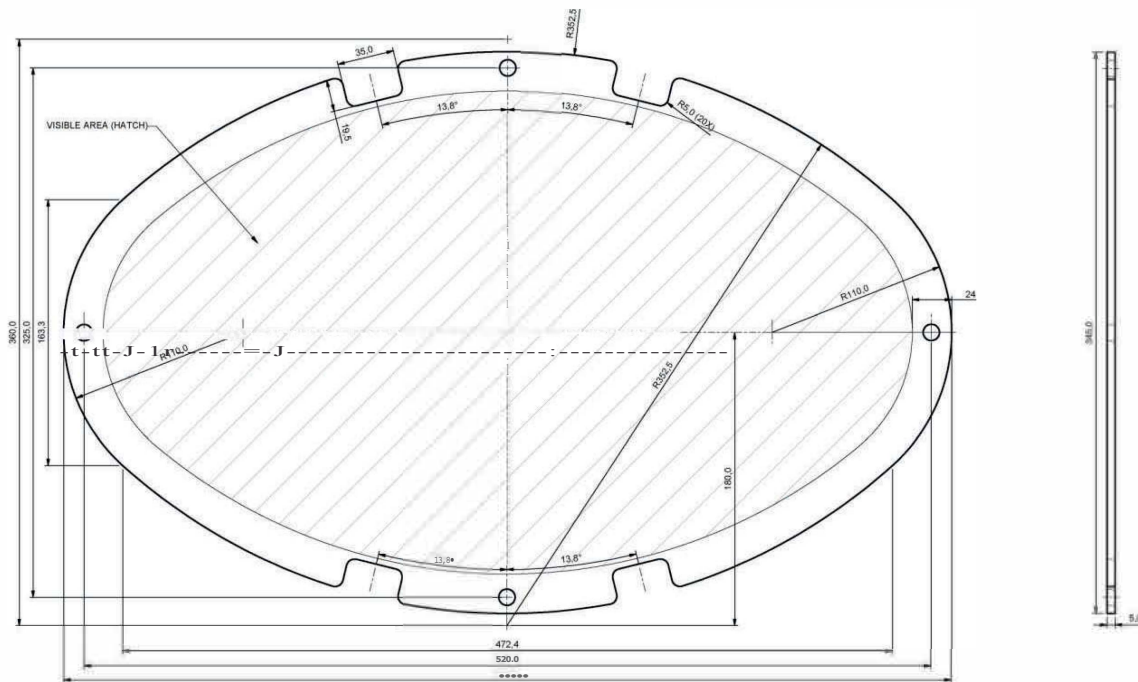

Figure 6: Front plate Elipse Compact (104-0201)

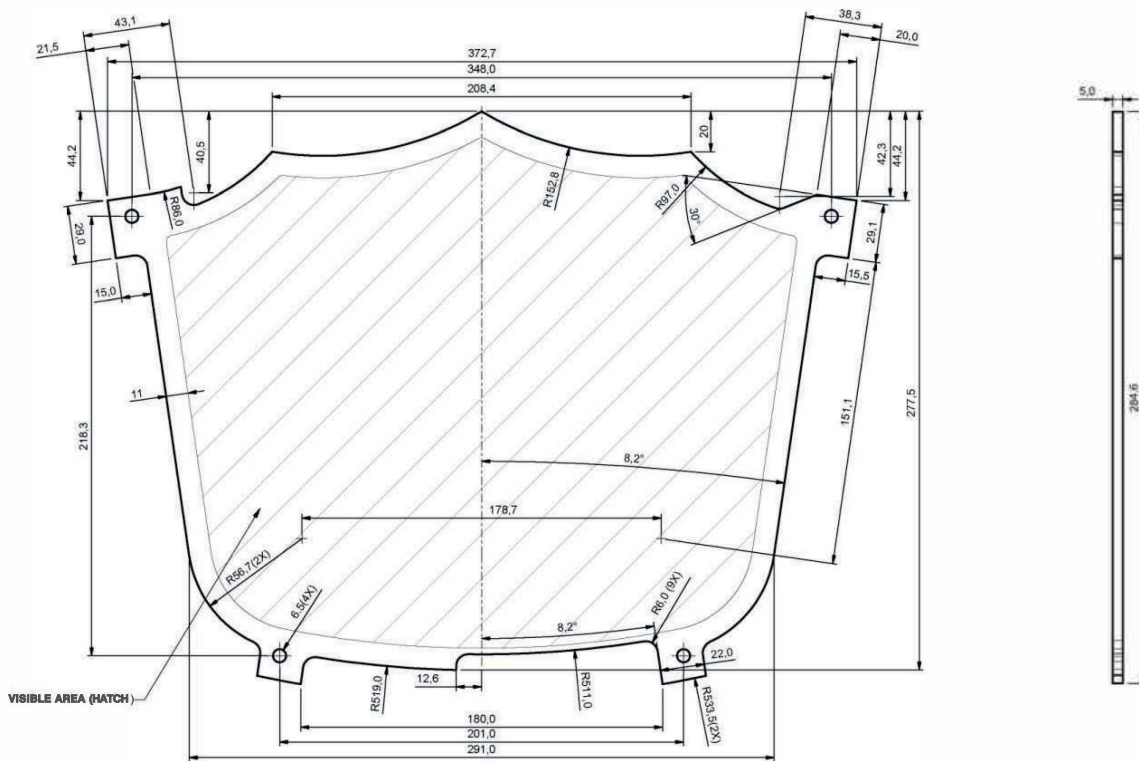

Figure 7: Front plate Shield (104-0301)

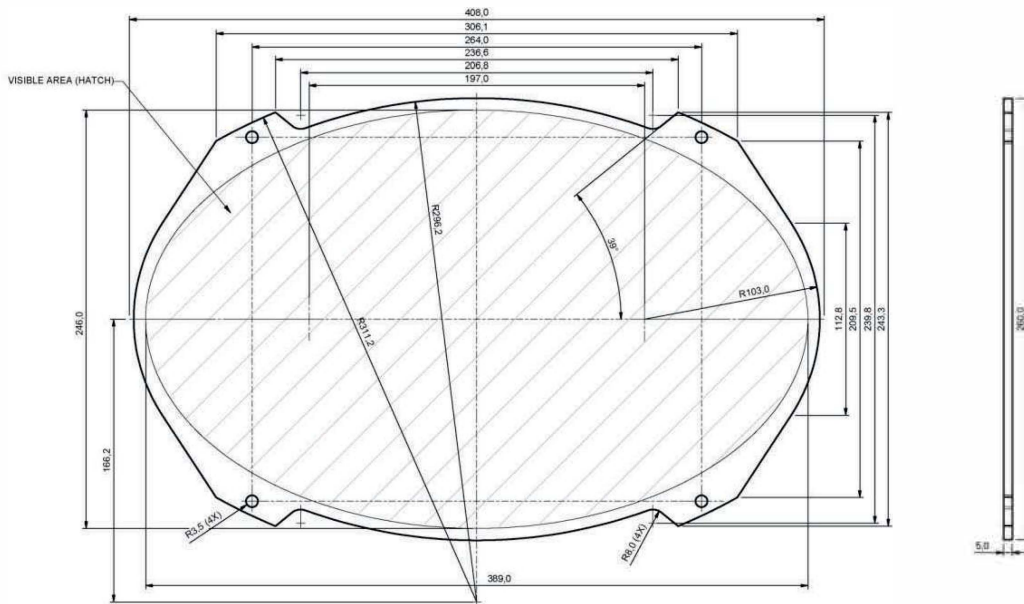

Figure 8: Front plate Mini Topper (104-0601)

3.6 Topper Base options



Figure 9: Base Topper 15 degrees slanting (104-0010-2)



Figure 10: Base Topper BCT Rio (104-0014-2)



Figure 11: Base Topper R260 curved (104-0015-2)



Figure 12: Base Topper flat mounting (104-0020-2)

3.7 Topper Base dimensions

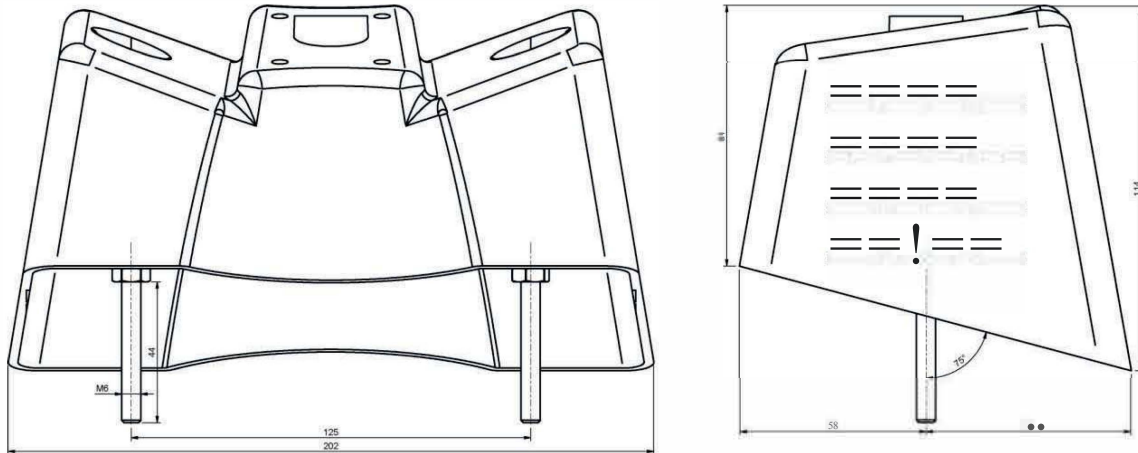

Figure 13: Base Topper 15 Degrees slanting (104-0010-2)

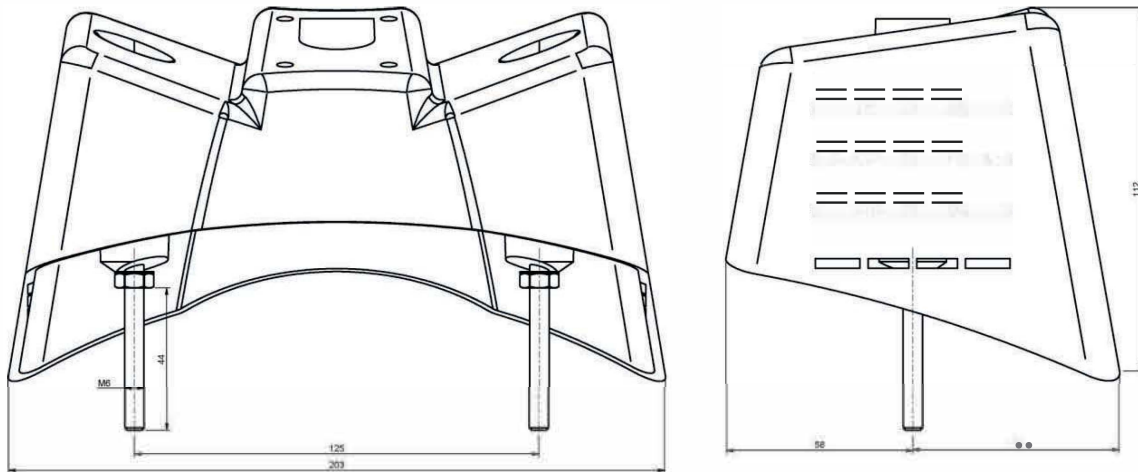

Figure 14: Base Topper R260 curved (104-0014-2)

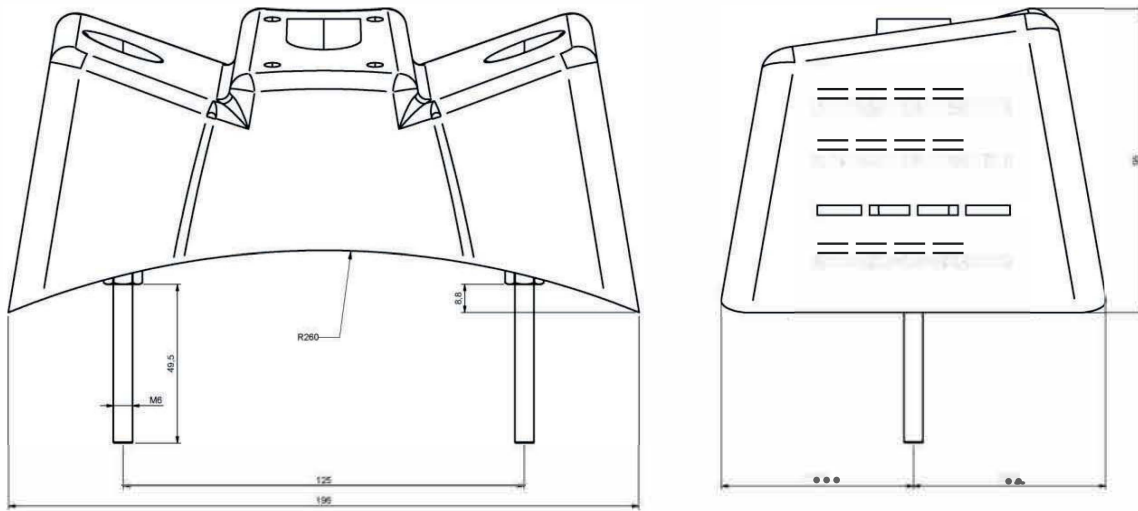

Figure 15: Base Topper R260 curved (104-0015-2)

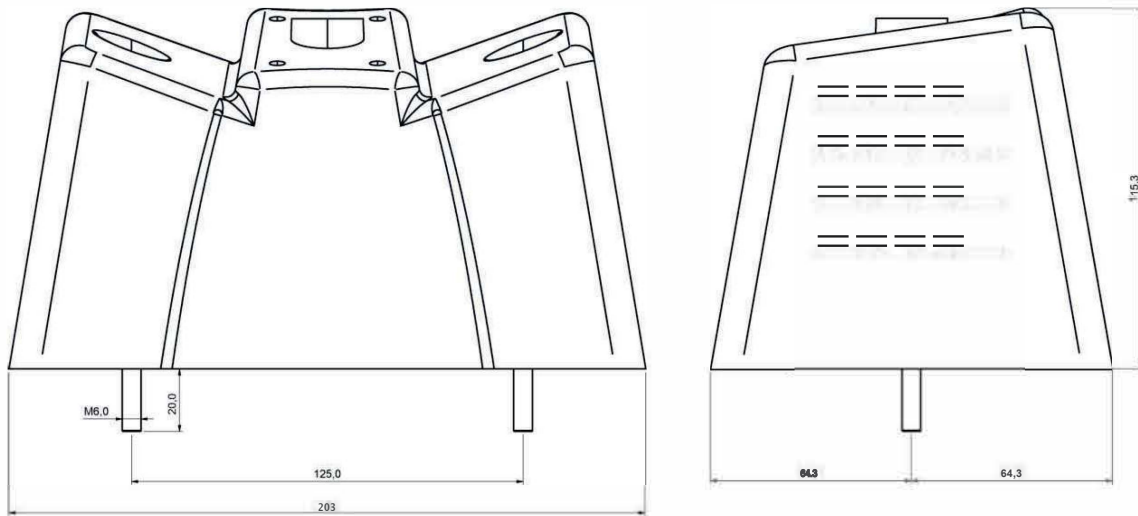

Figure 16: Base Topper flat mounting (104-0020-2)

4. Installation

Important: Shut-off the power from the host machine until any installation work is completed.

Power supply must be 12VDC, 2Amp.

4.1 Connection

Wire color	Description	Pio	
Orange	Power 12Vdc	1	2 Pole Connector
Black	Power Ground	2	
Black	Common Tower light	1	4 Pole Connector
Yellow	Lamp 2nd from bottom	2	
White	Lampbottom	3	
Blue	Lamp 3th from bottom	4	
Braided strap	Earth bonding strap		Ring Term. 4mm

Table 1: Connection

Topper connector type	Machine connector type
MolexMale 03-09-2022	Molex Female 03-09-1022
03-09-2049	03-09-1049
02-09-2118	02-09-1118

Table 2: Connector type

4.2 Lamp

The following lamp type is used in the topper unit:



Figure 17: Dulux SIE Lamp IIW/827 (-9904-11)

5. Technical specifications

5.1 Electrical ratings

Parameter	Value	Units
Power Supply	12 +/- 10%	Vdc
Current consumption	1.5	A
Image refresh rate	63	Hz
Intensity levels	8	

Table 3: Technical specifications

5.2 Schematic diagram

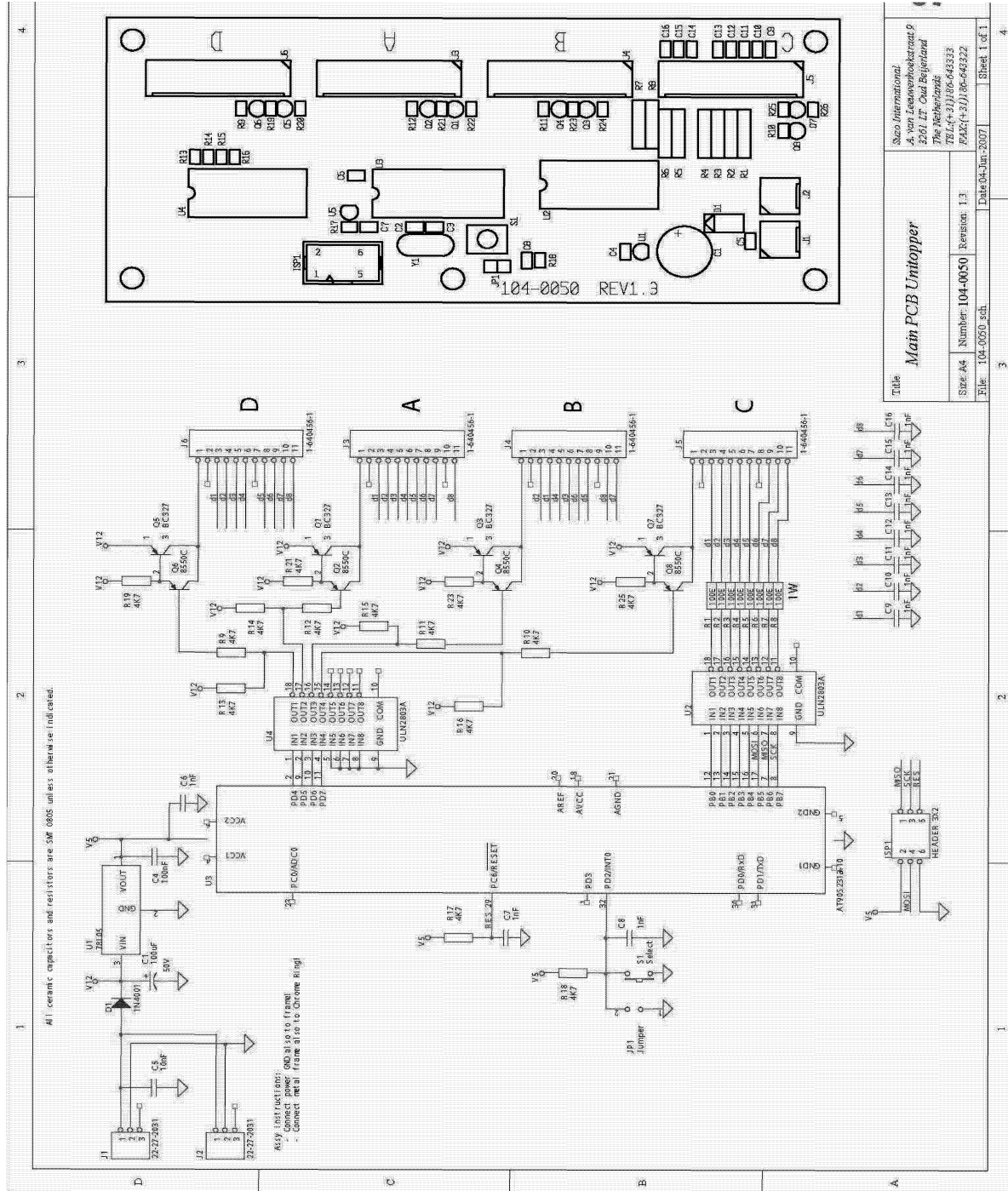

Figure 18: Schematic and Layout