

## NV9 USB+

### Enhanced sensing technology

The NV9 USB+ is the next generation banknote validator, boasting enhanced sensing technology and a high acceptance rate for multi-currency. NV9 USB+ is a versatile banknote validator with cashbox and bezel options to suit all applications. The unit can be mounted horizontally or vertically and exceptional field reliability make the NV9 USB+ a truly global product. A note float module can be added to provide note recycling capability.

#### Features

- Various cashbox and bezel options
- Proven field reliability
- Enhanced sensing technology = high acceptance rate for multi-currency
- Easy maintenance, free firmware updates
- Over 100 different world currencies accepted
- Optional note float unit

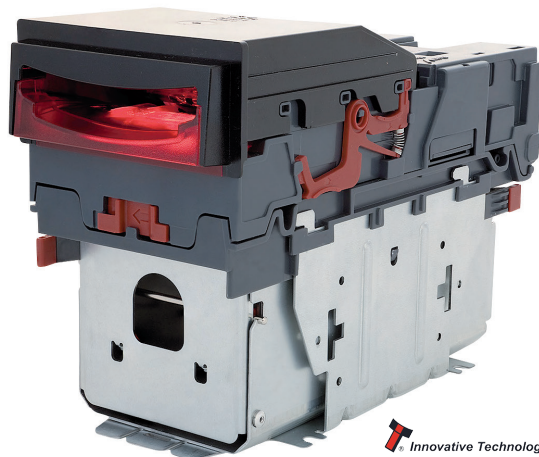

 Innovative Technology

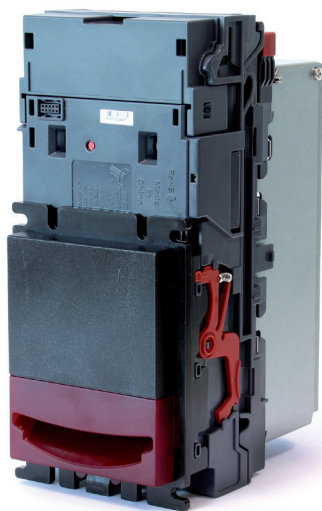

#### Benefits

- Versatile validator, suitable for all applications
- Lowest cost of ownership
- Takes more cash
- Future proof - quick & easy updates via USB, PC or handheld programmer
- A truly global product
- Ability to add note recycling

Multiple cashbox option

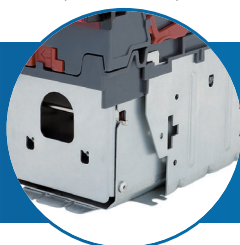

Different illumination options



## Technical Schematics

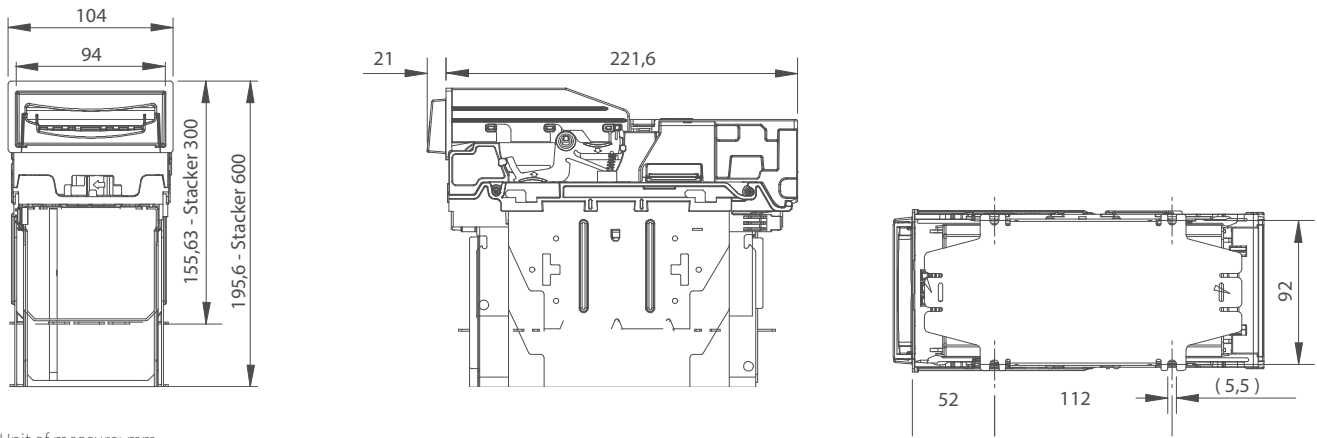

Unit of measure: mm

### Tools

#### DA2 kit

Kit for programming, configuration and diagnostics



#### DA3 kit

Kit for on field programming and configuration



#### DA3 Easy

Easy and intuitive kit for on field programming



### Interfaces

- USB
- Open Collector

### Protocols

- SSP
- Parallel
- ccTalk
- Binary
- MDB
- Serial
- Pulse



### Bezel Options

- 66/69/78/82 mm width
- Vertical up/down
- Horizontal
- Various illumination options

### Optional accessories

- AGCAVOSMILE: cable for connecting the banknote reader to its host machine in parallel mode. Available lengths: 20 - 50 - 100 - 150 cm
- AGCAVOSMILEPULS: cable for connecting an NV9 in pulse mode. Available lengths: 100 and 200 cm
- IF5: interface for converting the SSP protocol to MDB mode

## Technical Specifications

Dimensions (LxHxW) (*) horizontal orientation	With 300 banknote stacker 104 x 155.6 x 221.6 mm	With 600 banknote stacker 104 x 195.6 x 221.6 mm
Weight	1,700 g	
Power supply	12 Vdc +/- 10% (MDB version: min. 23 V - max 42 V)	
Current consumption	0.2A Standby - 1A Running - 1.5A Peak	
Operating temperature	3 °C ÷ 50 °C - 5 ÷ 95% humidity non-condensed	
Banknotes accepted	up to 82 x 160 mm	
Recognisable banknotes	up to 15 different banknote denominations in serial, pulse and binary validation modes 4 banknotes in parallel mode	
Acceptance speed	3 ÷ 6 seconds	
Capacity	Cashbox: 300 lockable - 300/600 slide - 300/600 clip Recycler: 30 notes	
MCBF	200,000	