

NV11 USB+

Market leading compact note recycler

NV11 USB+ is the ideal solution in a variety of situations where high security and high volume banknote acceptance, validation and payout are needed: kiosks, gaming machines, parking, ticketing and vending machines. NV11 USB+ is equipped with the innovative Note Float payout unit and can store and recycle up to 30 notes.

Features

- 300 or 600 note storage capacity
- 30 note single denomination recycler
- Proven field reliability
- Accepts, validates and stores banknotes in less than 3 seconds
- Easy maintenance, free firmware updates
- Uses a secure encrypted protocol for data transfer

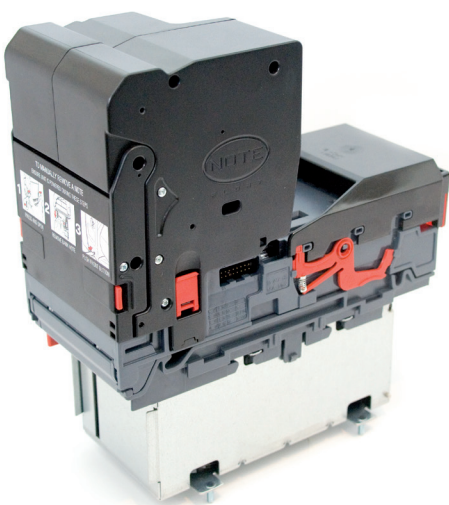
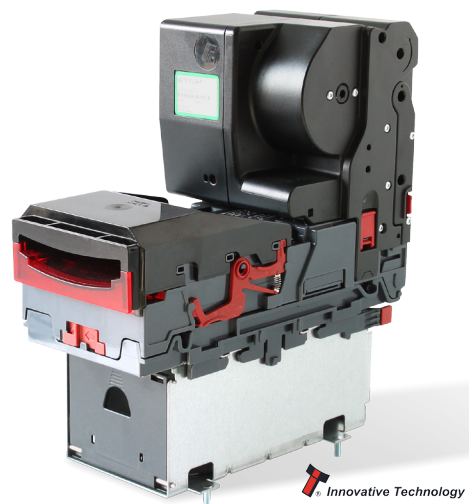

Benefits

- Maximises cash efficiency and reduces operational costs
- Lowest cost of ownership
- Future proof – quick & easy updates via USB, PC or handheld programmer
- Lowest operator collection costs

Bezel



Note Float Unit



Technical Schematics

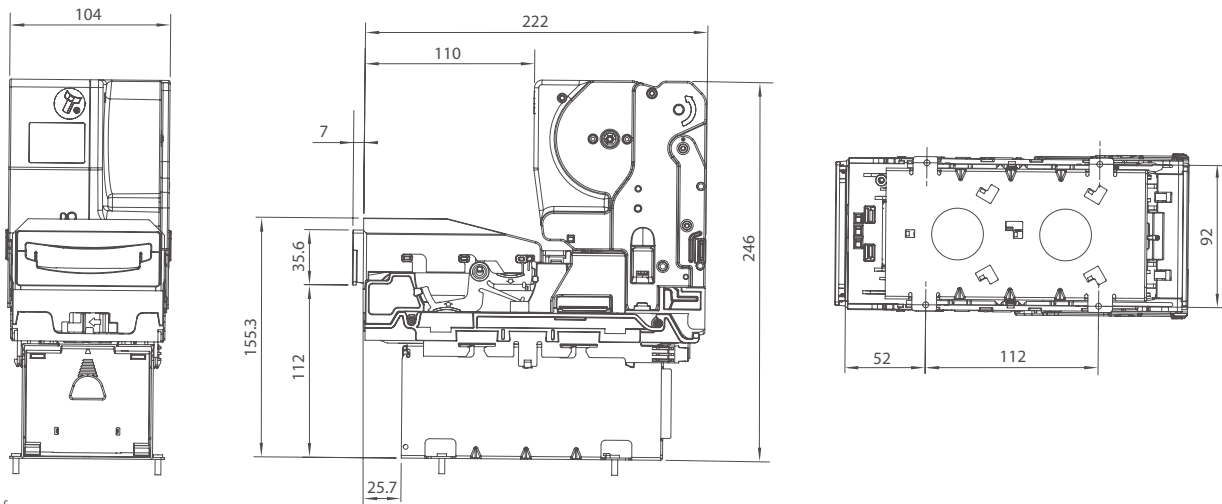

Unit of measure: mm

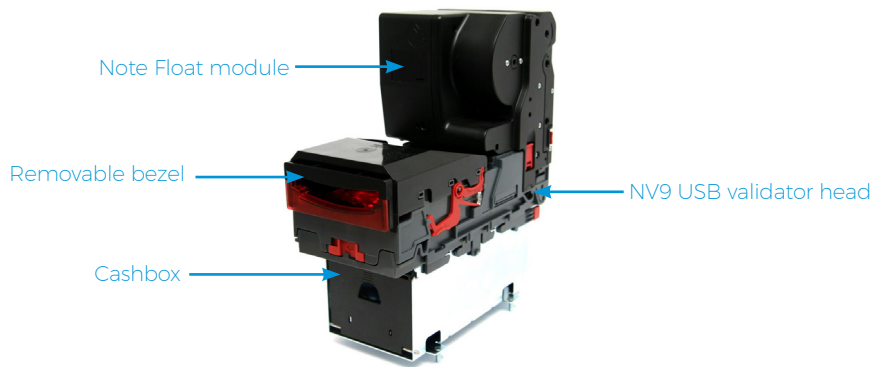

Tools

DA2 kit

Kit for programming, configuration and diagnostics



DA3 kit

Kit for programming and configuration on field



DA3 Easy

Easy and intuitive kit for programming on field



Protocols

- ccTalk
- eSSP (encrypted Smiley Secure Protocol)

Interface

- USB
- Open Collector

Bezel Options

- 82 mm horizontal
- 82 mm chamfered
- Rainbow illumination

Technical Specifications

Dimensions (LxHxW)	104x246x229 mm
Weight	2.2 Kg
Power supply	12 Vdc +/- 10%
Current consumption	350 mA Standby – 3A Running – 3.5A Peak
Operating temperature	3°C ÷ 50°C 5 ÷ 95% humidity non-condensed
Note dimensions	Width 60-82 mm Length 115-150 mm
Speed	3 seconds
MCBF	200,000

Banknotes Capacity

Capacity	Cashbox: 300 standard – 300 lockable – 300/600 slide Recycler: 30 notes
----------	--