

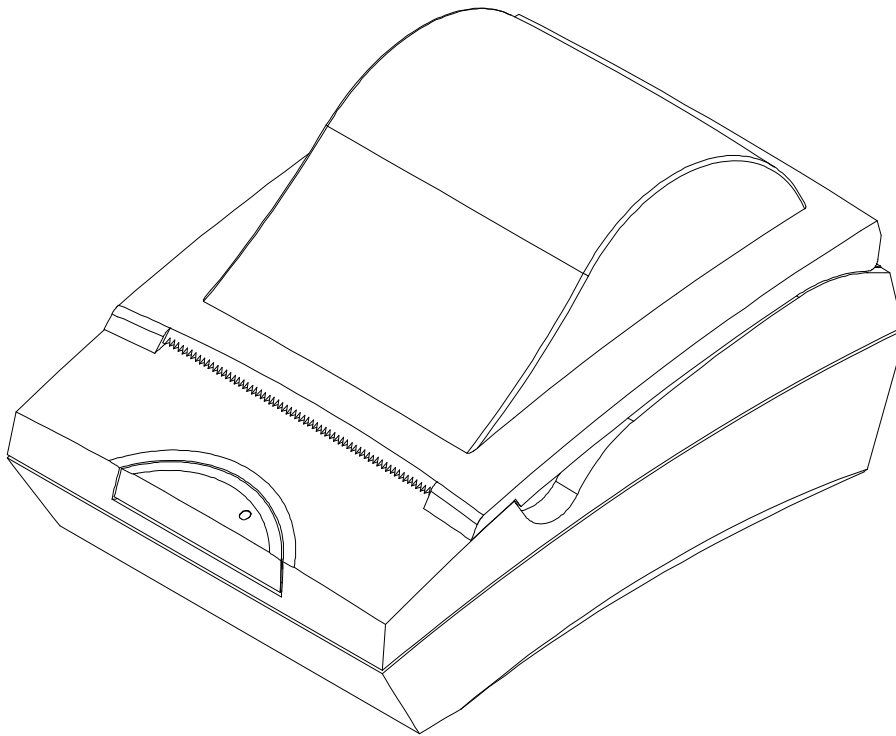

# Spill-Proof Thermal Printer

## *Owner's Manual*



First Edition: April 2003  
Last Revision: April 2013

Document #: 102136-0003R-01

**NANOPTIX**

## Legal Notices

### Disclaimer

Information in this document is subject to change without notice. Consult your Nanoptix Inc. sales representative for information that is applicable and current. Nanoptix Inc. reserves the right to improve products as new technology, components, software, and firmware becomes available.

No part of this document may be reproduced or transmitted in any form or by any means, electronic or mechanical, for any purpose without the express written permission of Nanoptix Inc.

### Copyright

Copyright 2006 by Nanoptix Inc.  
Dieppe, New Brunswick Canada  
All rights reserved  
Printed in Canada  
Confidential, Unpublished  
Property of Nanoptix Inc.

### Trademarks

Epson is registered trademark of Epson Corporation.

Windows is registered trademark of Microsoft Corporation.

Nanoptix is a trademark. Other trademarks and registered trademarks are the property of their respective holders.

### Federal Communications Commission (FCC) Radio Frequency Interference Statement

#### Warning

Changes or modifications to this unit not expressly approved by the party responsible for compliance could void the user's authority to operate the equipment.

#### Note

This equipment has been tested and found to comply with the limits for a Class B digital device, pursuant to Part 15 of the FCC Rules. These limits are designed to provide reasonable protection against harmful interference when the equipment is operated in a commercial environment. This equipment generates, uses, and can radiate radio frequency energy and, if not installed and used in accordance with the instruction manual, may cause harmful interference to radio communications. Operation of this equipment in a residential area is likely to cause harmful interference in which case the user will be required to correct the interference at his own expense.

#### Information to the User

This equipment must be installed and used in strict accordance with the manufacturer's instructions. However, there is no guarantee that interference to radio communications will not occur in a particular commercial installation. If this equipment does cause interference, which can be determined by turning the equipment off and on, the user is encouraged to contact Nanoptix Inc. immediately.

## Spill-Proof Thermal Printer Owner's Manual

Nanoptix Inc. is not responsible for any radio or television interference caused by unauthorized modification of this equipment or the substitution or attachment of connecting cables and equipment other than those specified by Nanoptix Inc. The correction of interferences caused by such unauthorized modification, substitution or attachment will be the responsibility of the user.

In order to ensure compliance with the Product Safety, ICES, FCC and CE marking requirements, you must use the power supply, power cord, and interface cable which were shipped with this product or which meet the following parameters:

### **Power Supply**

UL Listed power supply with standard 60Hz-50Hz, 100-240VAC input and 24VDC output equipped with AC line filtering, over-current and short-circuit protection.

Use of this product with a power supply other than the Nanoptix Inc. power supply will require you to test the power supply and Nanoptix Inc. printer for FCC and CE mark certification.

### **Communication Interface Cable**

An approved Nanoptix interface cable must be used with this product. Using a cable other than Nanoptix approved product will require that you test the cable with the Nanoptix Inc. printer and your system for FCC and CE mark certification.

### **Power Cord**

A UL listed, detachable power cord must be used. A power cord with Type SVT marking must be used. For applications outside the North America, power cords that meet the particular country's certification and application requirements should be used.

Use of a power cord other than described here may result in a violation of safety certifications that is in force in the country of use.

### **Industry Canada (IC)**

#### **Radio Frequency Interference Statement**

This Class A digital apparatus meets all requirements of the Canadian Interference-Causing Equipment Regulations.

*Cet appareil numérique de la classe A respecte toutes les exigences du Règlement sur le matériel brouilleur du Canada.*

## Table of Contents

<b>1. About the Printer .....</b>	<b>1</b>
1.1 Description of Printer .....	1
1.2 Connection .....	2
1.3 General specifications.....	3
1.4 Printer Controls.....	4
To reset Printer .....	4
Paper Feed Button.....	5
1.5 Changing Paper .....	6
1.6 Testing the Printer .....	7
1.7 Troubleshooting the Printer .....	8
Printer LED .....	8
Printing Problems .....	8
Printer Does Not Work.....	9
<b>2. Media and Supplies Guide.....</b>	<b>10</b>
2.1 Thermal Paper Specifications.....	10
2.2 Ordering Thermal Paper .....	10
2.3 Ordering Miscellaneous Supplies .....	11
Power Supply and Power Cord.....	11
Ordering Communication Cables.....	11
Communication Cables Pin-Out .....	12
<b>3. Communicating with the Printer .....</b>	<b>14</b>
<b>APPENDIX A: Mechanical Drawings.....</b>	<b>15</b>

## Figures

<b>FIGURE 1: NANOPTIX SPILL-PROOF PRINTER.....</b>	<b>1</b>
<b>FIGURE 2: NANOPTIX SPILL-PROOF CONNECTION THROUGH PLASTIC HOOK .....</b>	<b>2</b>
<b>FIGURE 3: NANOPTIX SPILL-PROOF OPTIONAL PLASTIC COVER .....</b>	<b>2</b>
<b>FIGURE 4: RESETTING PRINTER.....</b>	<b>4</b>
<b>FIGURE 5: PAPER FEED BUTTON.....</b>	<b>5</b>
<b>FIGURE 6: LOADING PAPER.....</b>	<b>6</b>
<b>FIGURE 7: TEST TICKET EXAMPLE.....</b>	<b>7</b>
<b>FIGURE 8: MECHANICAL DIMENSIONS .....</b>	<b>15</b>

## Tables

<b>TABLE 1: SPECIFICATION .....</b>	<b>3</b>
<b>TABLE 2: TROUBLESHOOTING WITH THE STATUS LED.....</b>	<b>8</b>
<b>TABLE 3: TROUBLESHOOTING PRINTING PROBLEMS .....</b>	<b>8</b>
<b>TABLE 4: PRINTER DOES NOT WORK .....</b>	<b>9</b>
<b>TABLE 5: THERMAL PAPER PART NUMBERS.....</b>	<b>10</b>
<b>TABLE 6: ORDERING THERMAL PAPER .....</b>	<b>10</b>
<b>TABLE 7: POWER CORD PART NUMBERS.....</b>	<b>11</b>
<b>TABLE 8: COMMUNICATION CABLES PART NUMBERS.....</b>	<b>11</b>
<b>TABLE 9: RS-232 DB9 FEMALE INTERFACE .....</b>	<b>12</b>
<b>TABLE 10: RS-232 DB9 MALE INTERFACE .....</b>	<b>12</b>
<b>TABLE 11: RS485/RS232 COMBO DB15 FEMALE INTERFACE .....</b>	<b>13</b>
<b>TABLE 12: CASH DRAWER INTERFACE .....</b>	<b>13</b>

# 1. About the Printer

## 1.1 Description of Printer

The Nanoptix Spill-Proof thermal printer is extremely fast, quiet, and very reliable. With thermal printing technology, there is no ribbon cassette to change, and paper loading is extremely simple. The printer is small enough to fit almost anywhere and is easy to use with the ticket exiting from the top.

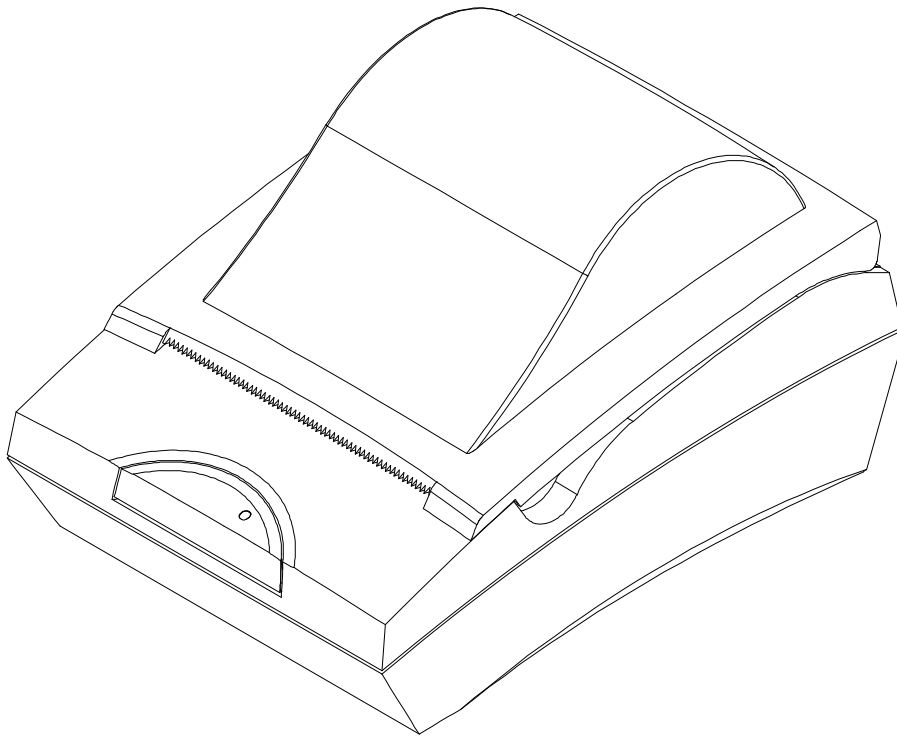

**Figure 1: Nanoptix Spill-Proof Printer**

## 1.2 Connection

To prevent the Nanoptix Spill-Proof Printer from accidental disconnect. The USB and the Power cable can be hooked to the plastic clip as shown in Figure 2. To increase protection, an optional plastic cover is available over the back connection as shown in Figure 3.

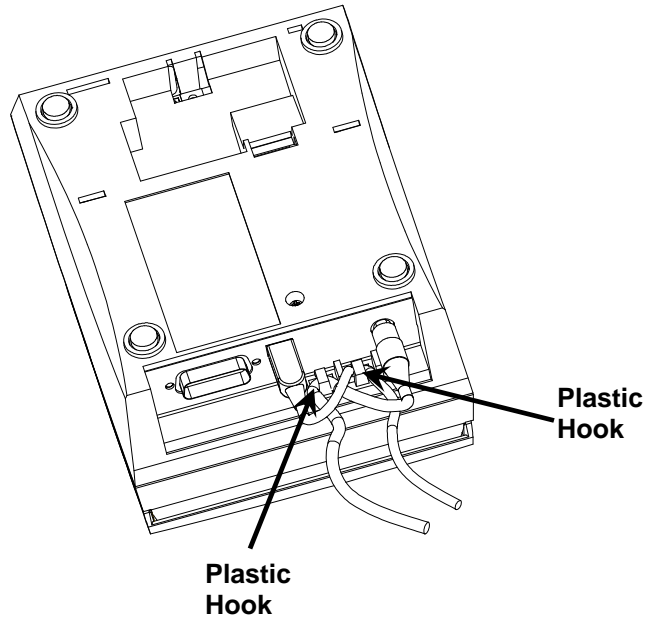

Figure 2: Nanoptix Spill-Proof Connection through Plastic Hook

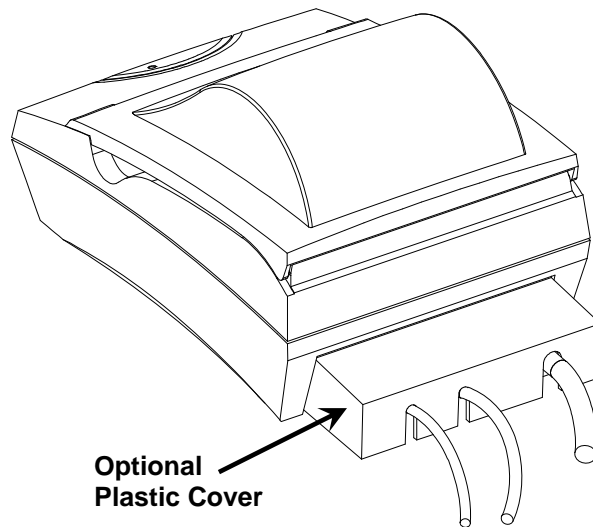

Figure 3: Nanoptix Spill-Proof Optional Plastic Cover



## 1.3 General specifications

<b>Print Method</b>	Direct Thermal
<b>Resolution</b>	8 dot/mm (203 dpi)
<b>Print Width</b>	80mm
<b>Paper Width</b>	80mm or 82.5 mm
<b>Max Roll Diameter</b>	82.5mm
<b>Operating Temperature</b>	0 to 50 C
<b>Storage Temperature</b>	-40 C to +65 C
<b>Operating Relative Humidity</b>	5% to 90% RH at 50C (non-condensing)
<b>Communication Interface Options</b>	USB and RS-232C, optional RS-485
<b>Optional Interface</b>	Cash Drawer Kick Out
<b>Memory/Firmware</b>	64 Mbit of RAM, 16 Mbit of flash
<b>Resident Character Sets</b>	Arial Bold (6 sizes) Note: Other Character sets can be programmed quickly
<b>Integrated Bar Codes</b>	UPC-A, UPC-E, interleaved 2 of 5, Code 39, Code 128, EAN 8, EAN 13.
<b>Speed</b>	Up to 125 mm/second
<b>Sensors</b>	<ul style="list-style-type: none"> <li>• Paper out</li> <li>• Door open</li> <li>• Top of form (optional)</li> </ul>
<b>Human Interface</b>	Drop-in paper loading, status LED, paper feed button
<b>Dimensions</b>	130mm width x 110mm height x 180mm depth
<b>Weight</b>	0.55 Kg
<b>Agency Compliance</b>	Underwriters Laboratory - UL 60950 Safety of Information Technology Equipment, including Electrical Business Equipment
	Canadian Standards Association - CSA 22.2 No. 60950 Safety of Information Technology Equipment, including Electrical Business Equipment
	TUV / VDE / GS Mark Safety of Information Technology Equipment, including Electrical Business Equipment
	Underwriters Laboratories - IEC 60950 / EN 60950 CB Test Report and Certificate
<b>Emission Standards</b>	United States - FCC Part 15 Subpart B Canada - Industry Canada ICES-003 Europe – EN 55022 Class A emissions

**Table 1: Specification**

## 1.4 Printer Controls

### To reset Printer

Simply plug and unplug the printer to reset in the event of a fault condition. Once the Printer is re-plugged, it will go through a startup routine and resets itself.

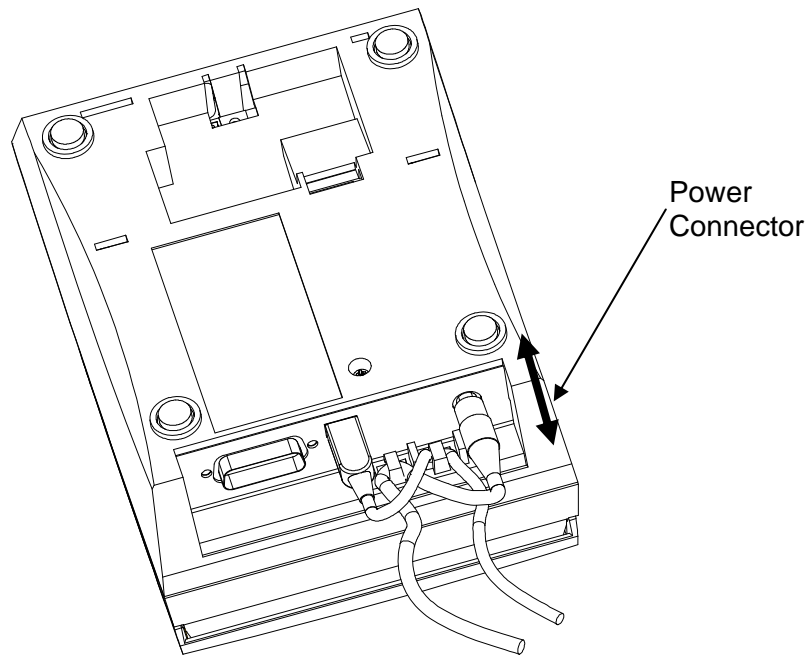

**Figure 4: Resetting Printer**

## Paper Feed Button

Use the Paper Feed Button to advance the paper.

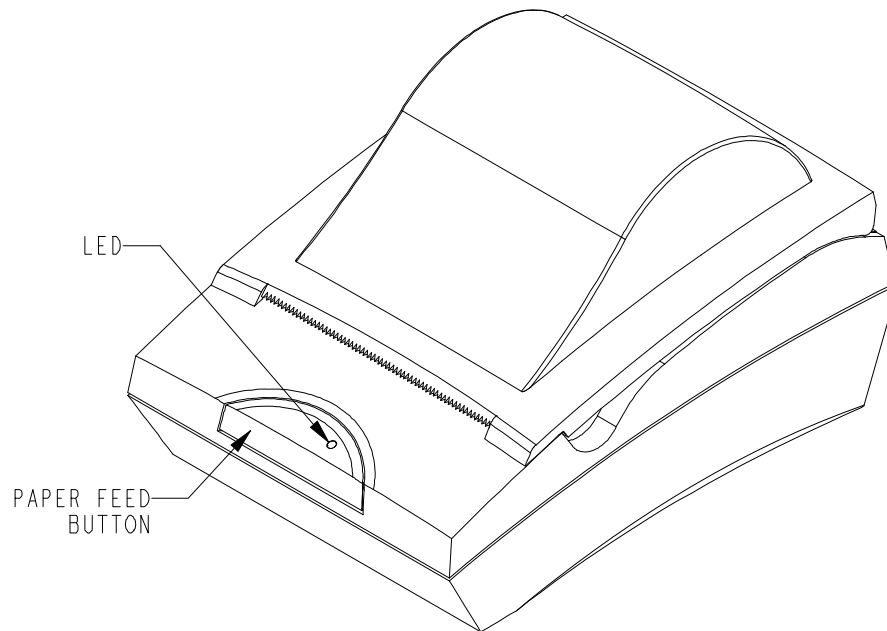
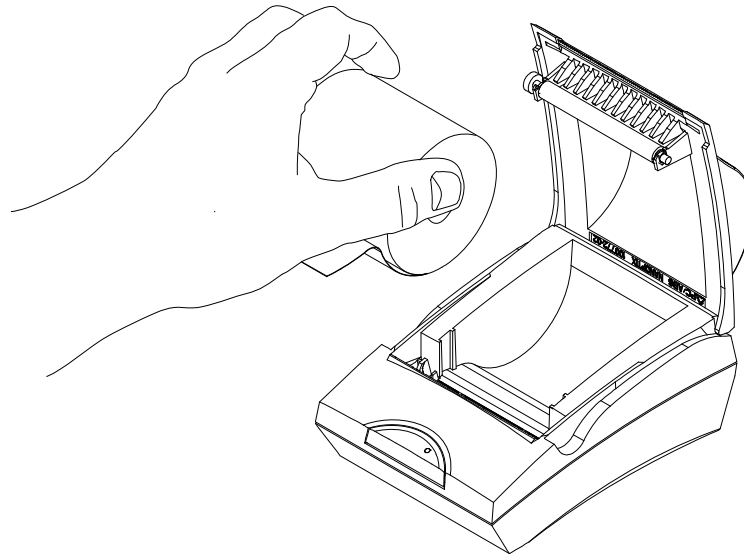

**Figure 5: Paper Feed Button**

## 1.5 Changing Paper

**Caution:** Do not operate the printer if it runs out of paper. The printer will not operate without paper, but it may continue to accept data from the host computer. Because the printer cannot print any transactions, the data may be lost.

1. Open the top cover by pulling under the tab on both sides.
2. Remove the used roll.
3. Tear off the end of the new roll so that the edge is loose and place the new roll into the paper bucket with a few inches of loose paper at the bottom of the roll.



**Figure 6: Loading Paper**

**Caution:** Be sure the paper unrolls from the bottom. Otherwise, the printer will not print or the paper will jam.

4. Pull up on the bottom of the paper roll and align the paper properly before closing the cover.
5. Advance the paper by pressing on the paper feed button and tear off the excess paper.

**Note:** In the event of a paper jam, remove the roll, tear a new clean edge, and replace it in the paper bucket, as described above. Be sure that the paper unrolls from the bottom of the roll.

## 1.6 Testing the Printer

Run this test to check the printer. The test prints and cuts a resident test ticket. Verify this ticket to ensure unit is printing and operating correctly. \*The test ticket may vary from actual printout depending on revision, firmware chosen.

Model:	CALLISTO
Firmware:	C21-2.41G-61UCS
<b>COMMUNICATION</b>	
Interface:	IEEE1284 (0) or
Serial	
Baud:	9600
Data Bits:	8
Parity:	NONE
Handshaking:	NONE
Print Mode:	NTL
Aux Port:	Disabled
<b>PRINT CONTROL</b>	
Darkness Control:	-1%
Voltage:	24.2 Volts
Temperature:	26 Celcius
Speed:	4 IPS
Black Bar Index:	Disabled
<b>SYSTEM RESOURCES</b>	
FLASH	
-Used:	0
-Free:	24576
<b>LIBRARY INVENTORY</b>	
Templates:	0,1,2
Print Regions:	1,2,3,4,5,6,7,8, h,9,A,B,C,D,E,F,G, I,J,K,L,N,O,P,Q,R, S,T,U,Z,X,a,b,c,d, e,f,g,i,j,k,l,m,n, o,p,q,
Graphics:	None
Fonts:	0,3,5,7,8
<b>MANUFACTURING INFORMATION</b>	
Printer ID:	5465789
Date Code:	20184
PWM Setting:	7F7F7F7FFFFFFF
A to D:	DE7AA400FD000000
Resets:	9

**Figure 7: Test Ticket Example**

To print the test ticket, power-on the printer while pressing and holding the Paper Feed Button for approximately 3 seconds. A test ticket similar to above will be printed approximately 5 seconds after. Press the paper feed button once more and the ticket will feed. Pressing the button again will result in blank tickets.

## 1.7 Troubleshooting the Printer

The printer is simple and generally trouble-free, but from time to time minor problems may occur. Follow these procedures to determine the cause and resolution of any problems the printer may be having. If the procedures in this section do not correct the problem, contact a service representative.

### Printer LED

Condition	LED Status
Unit ready	ON
Unit is in Reset or Booting	OFF
Unit in standby (powered off)	OFF
Paper Out	Slow Blink
Door Open	Fast Blink
Paper Jam	Fast Blink
Missing Black Index Mark	Fast Blink
Temperature Error	Med Blink
Voltage Error	Med Blink
Print Head Error	Med Blink

**Table 2: Troubleshooting with the status LED**

### Printing Problems

Problem	Possible Causes	What to Do
Receipt does not come out all the way.	Paper is jammed.	Open the top cover, inspect and clear any jammed paper.
Printer starts to print, but stops while the receipt is being printed.	Paper is jammed.	Open the receipt cover, inspect and clear any jammed paper.
Print is light or spotty.	Paper roll loaded incorrectly.	Check that the paper is loaded properly.
	Thermal printhead is dirty.	Use recommended thermal receipt paper. Clean the Print Head with Nanoptix authorized cleaner.
Vertical column of print is missing.	This indicates a serious problem with the printer electronics.	Contact your authorized service representative.
One side of receipt is missing.	This indicates a serious problem with the printer electronics.	Contact your authorized service representative.

**Table 3: Troubleshooting Printing Problems**

## Printer Does Not Work

<b>Problem</b>	<b>Possible Causes</b>	<b>What to Do</b>
Printer Does Not Function When Turned On.	Printer not plugged in.	Check that printer cables are properly connected on both ends. Check that the host or power supply is switched on. Check Printer LED.
	Door not fully closed.	Close the door.

**Table 4: Printer Does Not Work**

## 2. Media and Supplies Guide

### 2.1 Thermal Paper Specifications

- Winding Direction: "Thermal Side Out"
- End of Roll: "Not attached to core"
- Core Inside Diameter: 0.5" (12.7mm)
- Maximum Roll Diameter: 3" (76.2mm)
- Paper Conversion: "Roll"
- Top of form mark: "Not required"
- Core Material: "Plastic"
- Core Fabrication: "Solid Wall"

### 2.2 Ordering Thermal Paper

Recommended thermal paper can be ordered direct from Nanoptix. Please specify the *Nanoptix part number* when ordering paper.

Nanoptix p/n	Paper Grade	Manufacturer	Paper Width	Thickness
100505-2010	P350	Kanzaki	80mm	61um (2.4mil)
100505-2016	P350	Kanzaki	82.5mm	61um (2.4mil)

**Table 5: Thermal Paper Part Numbers**

Manufacturer	Numbers
<b>Kanzaki Specialty Papers (USA)</b> 1350 Main Street • Springfield, MA 01103	1.888.KANZAKI Tel: 888-526-9254 Fax: 413-731-8864

**Table 6: Ordering Thermal Paper**

Additional grades can be qualified and made available. Contact your sales representative for more information from our toll free line at 1-888-983-3030.



## 2.3 Ordering Miscellaneous Supplies

### Power Supply and Power Cord

Please specify the *Nanoptix part number* when ordering power supplies and cords.

Nanoptix p/n	Part Description
102080-0000R	Power Cord - North America (standard C13 connector)
102080-0001R	Power Cord - Continental Europe (standard C13 connector)
102080-0003R	Power Cord - Argentina (standard C13 connector)
270005-0001R	24V, 60W Power Supply

**Table 7: Power Cord Part Numbers**

Contact your sales representative for more information from our toll free line at 1-888-983-3030.

### Ordering Communication Cables

Please specify the *Nanoptix part number* when ordering communication cables.

Part Number	Part Description
102085-0002R	USB communication cable (Type mini B to A)
102082-0000R	Serial cable (DB-9 male to DB-9 female)
102928-0000R	Serial cable (DB9 male to DB9 male)
102805-0000R	Serial Null Modem cable (DB9 female to DB9 female)
102927-0000R	Serial Null Modem cable (DB9 female to DB9 male)
102911-0000R	Adaptor harness (DB9 Female to RJ45)
102911-0001R	Adaptor harness (DB9 Male to RJ45)
102270-0000R	Cash Drawer harness (RJ11-RJ11)

**Table 8: Communication Cables Part Numbers**

Contact your sales representative for more information from our toll free line at 1-888-983-3030.

## Communication Cables Pin-Out

Your printer uses industry standard connections for Serial, USB and Cash Drawer functions and is therefore compatible with standard printers and hosts on the market.

Please note that due to the power requirements of thermal printers, the unit will not function with the USB cable alone. The power cord must be connected to the printer.

Several connector options are available depending on the printer factory configuration. For all cases, USB is installed. When installed, the Cash Drawer drivers can supply up to 2 Amp when not printing.

The tables below detail the connection pin-out for the RS-232 interface and cash drawer on the printer side.

Pin	Signal Name	Printer I/O	Host I/O	Printer Function
1	AUX_PWR	5V Output	n/a	Aux Power (100mA)
2	RS232_TXD	Output	Input	Data transmit
3	RS232_RXD	Input	Output	Data receive
4	RS232_CTS	Input	Output	Handshake
5	DGND	Ground	Ground	Signal Ground/Aux Ground
6	RS232_RTS	Output	Input	Handshake
7	RS232_CTS	Input	Output	Handshake
8	RS232_RTS	Output	Input	Handshake
9	nc or PWR	No connect	No connect	reserved

**Table 9: RS-232 DB9 female Interface**

Pin	Signal Name	Printer I/O	Host I/O	Printer Function
1	AUX_PWR	5V Output	n/a	Aux Power (100mA)
2	RS232_RXD	Input	Output	Data receive
3	RS232_TXD	Output	Input	Data transmit
4	RS232_RTS	Output	Input	Handshake
5	DGND	Ground	Ground	Signal Ground/Aux Ground
6	RS232_CTS	Input	Output	Handshake
7	RS232_RTS	Output	Input	Handshake
8	RS232_CTS	Input	Output	Handshake
9	nc or PWR	No connect	No connect	reserved

**Table 10: RS-232 DB9 male Interface**

Pin	Signal Name	Printer I/O	Host I/O	Printer Function
1	AUX_PWR	5V Output	n/a	Aux Power (100mA)
2	RS232_TXD	Output	Input	Data transmit
3	RS232_RXD	Input	Output	Data receive
4	No connect or CTS	Input	Output	None
5	DGND	Ground	Ground	Signal Ground/Aux Ground
6	Pull up or RTS	Output	Input	Handshake
7	RS232_CTS	Input	Output	Handshake
8	RS232_RTS	Output	Input	Handshake
9	Pull up	Output	Input	None
10	No connect	Reserved	Reserved	Reserved
11	RS485_-TXD	Output	Input	Handshake
12	RS485_+TXD	Output	Input	Handshake
13	RS485_-RXD	Input	Output	Handshake
14	RS485_+RXD	Input	Output	Handshake
15	DGND	Ground	Ground	Signal Ground/Aux Ground

**Table 11: RS485/RS232 combo DB15 Female Interface**

Pin	Signal Name	Printer I/O	Device I/O	Printer Function
1	DGND	Ground	Ground	Power Ground
2	Cash 1	Ground pulse	Sol- (A)	Solenoid (A) ground sink
3	V24	Supply	Sw & Sol+(A)	Solenoid/Switch Supply
4	V24	Supply	Sw & Sol+(A)	Solenoid/Switch Supply
5	Cash 2	Ground pulse	Sol- (B)	Solenoid (B) ground sink
6	Stat	Input	Switch	Drawer status

**Table 12: Cash Drawer Interface**

### 3. Communicating with the Printer

Over the years, Nanoptix has developed emulations for compatibility with the most popular printers in the market. At the time of printing this manual, the following emulations are available:

- Epson LQ570+
- Epson TM-T88III
- Star TUP-400
- Axiohm A722
- Ithaca P70
- Ithaca P170
- Citizen 3551

Please contact your sales representative if you require other emulations. If we do not have the emulation you need, we can provide most emulations in a short timeframe. If you are not required to emulate other printer, please ask your sales representative for the latest Nanoptix Windows Driver or the "Nanoptix Programming Guide" which will list the Nanoptix ESC/P commands.

## APPENDIX A: Mechanical Drawings

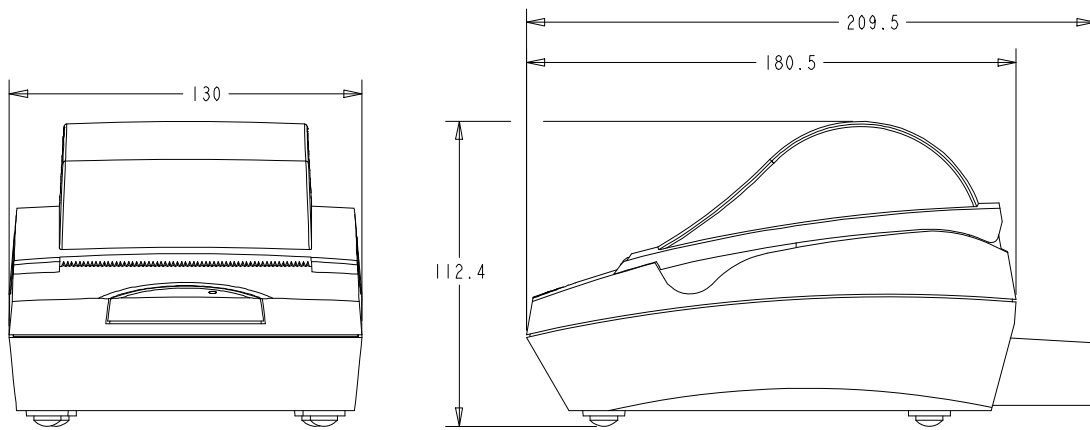

Figure 8: Mechanical Dimensions