

ICS (Intelligent Coin System)

The innovative coin handling device



The ICS is a revolutionary new coin handling machine able to process up to 8 different size coins without the need of pre-sorting the coins by the user. Due to its compact design and spacious size (up to 1,600 various sized coins), it is ideal for many applications, and supports a minimum coin-in to coin-out height solution.

Thanks to its patented design and SUZOHAPP's long standing experience in coin handling, this device is a world first currency solution, able to be integrated into various machines in different markets for example: parking ticket machines, self-checkout stations, money changers, kiosks and vending applications.

ICS's intelligent interface gives you the possibility to directly manage the payout composition or make the calculation itself as to the amount of coins per type to be supplied based on the denomination it holds. It is also able to dispense 4 coins simultaneously.

Features

- Compact design
- High capacity around 1,600 (euro mix)
- Up to 8 different denominations managed at the same time
- Customizable for country specific coin mix
- Wide coin diameter and thickness range
- Ready to dispense buffer of coins per denomination
- Simultaneous 4 coin payout per cycle (max 4 coins per second)
- Easy access for maintenance
- Coin diameter 15–32,5 mm
- Coin thickness 1,3–3,25 mm

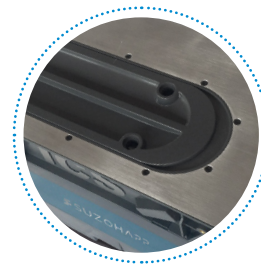

Compact design
One product that works as 8 hoppers + 1 sorter (Reduction of components integrated into the cabinet)

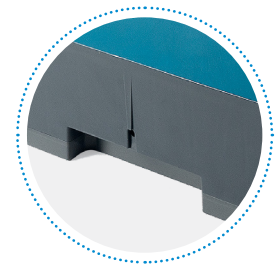

High payout speed and safety
It guarantees the correct payout per coins denominations

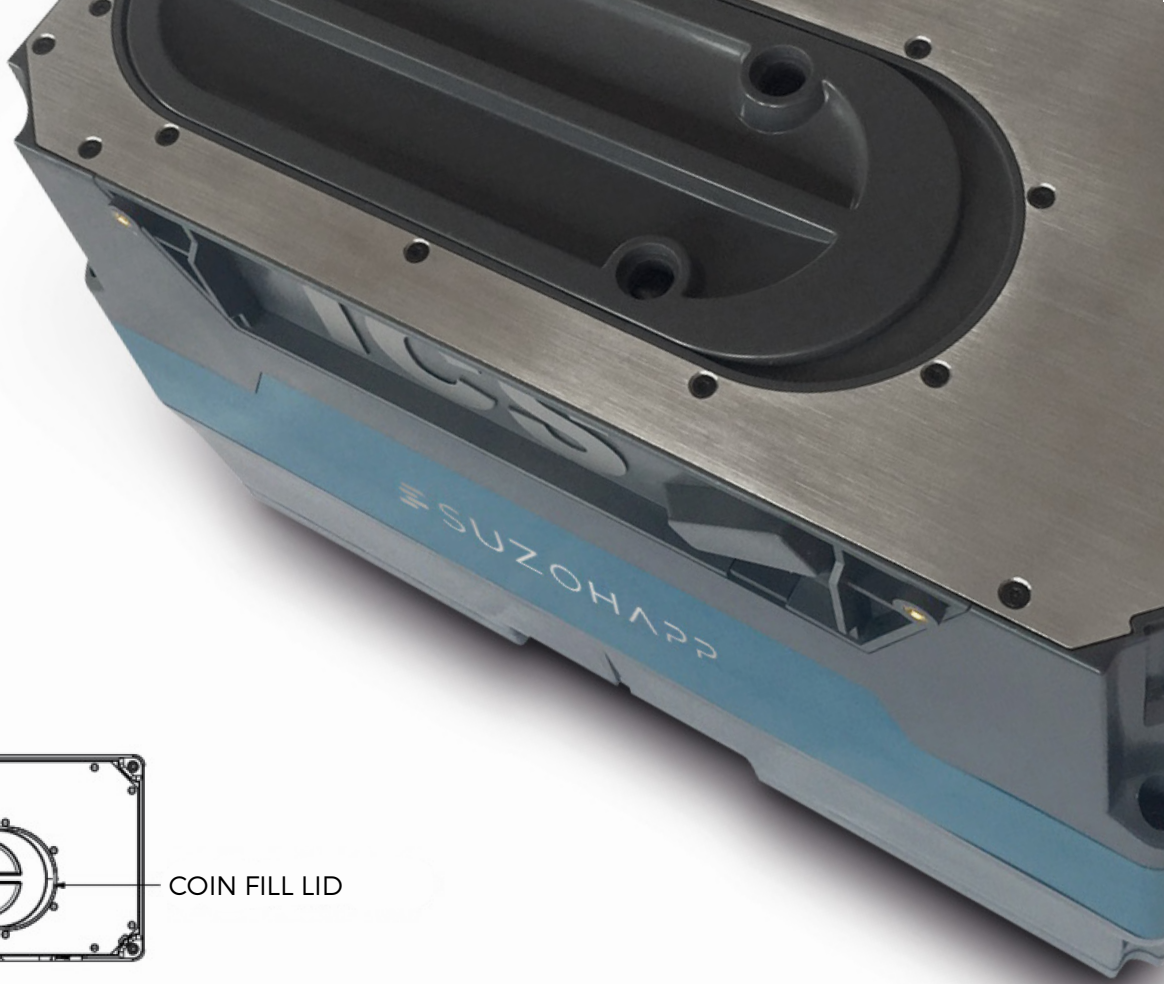

Technical Schematics

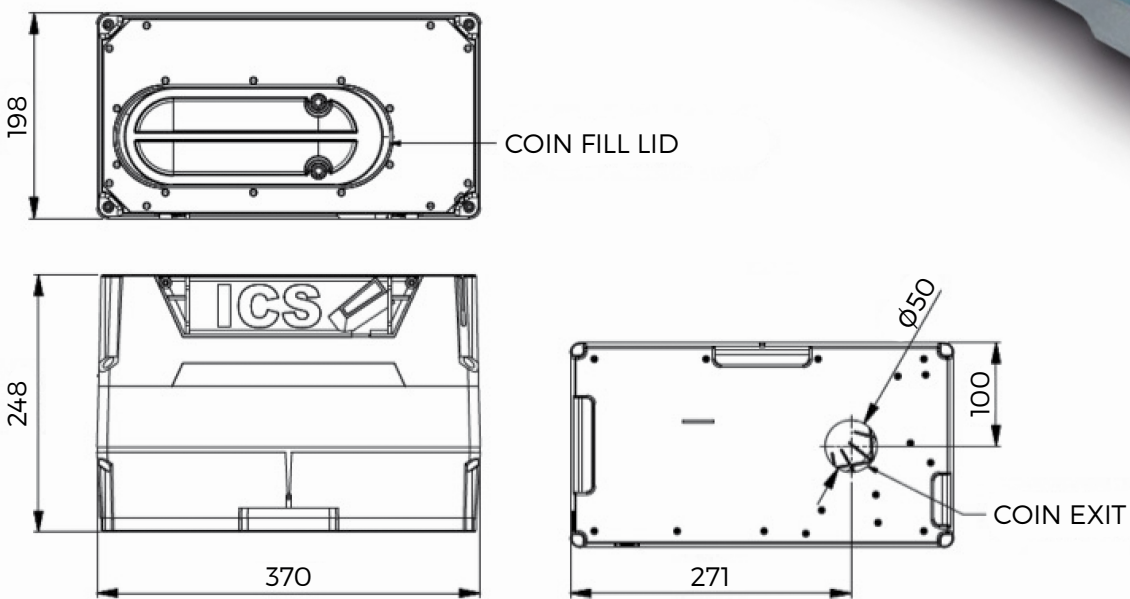

Unit of measure: mm

Technical Specifications

Dimensions (LxWxH)	370 x 198 x 248 mm
Supply voltage	12Vdc (+/-10%); 24Vdc (+/- 10%)
Storage Temperature	-20°C to 70°C
Operating Temperature	0°C to 50°C
Storage Humidity	10% to 95% non-condensing
Operating Humidity	10% to 75%