

# **BillPro™**



## **BillPro™ Bill Acceptor Operation and Service Manual**



# TABLE OF CONTENTS

---

## Section 1: General Information

Introduction .....	4
Models .....	4
For Your Records .....	4
Features .....	4
After Unpacking .....	4
Main Logic Board Assembly .....	4
Specifications .....	5
Dimensional Drawing .....	5

## Section 2: Installation

Options Setting .....	6
Setting the Configuration Options .....	6
Installing the Bill Acceptor .....	6

## Section 3: Operation

Bill Recognition .....	7
Bill Validation .....	7
Bill Stacking and Credit .....	7
Bill Rejection .....	7
Component Explanation	
Bill Transport and Stacking .....	7
Left and Right Alignment Sensors .....	7
Center Optic Sensor .....	7
Left and Right Optic Sensor .....	7
Magnetic Sensor .....	7
Anti-Pullback Levers .....	7
Stacker Home Sensor .....	7
Encoder Sensor .....	7
Component Explanation Drawing .....	8
Interconnect Drawing (BP) .....	9

## Section 4: Maintenance

Disassembling the BillPro .....	10
Disassembling the Chassis .....	13
Disassembling the Lower Housing .....	15
BillPro Cleaning Maintenance Procedure .....	17
Cleaning Salt Water Damage .....	17

## Section 5: Troubleshooting

Introduction .....	18
BillPro Diagnostic Flash Codes .....	18

## Section 6: Parts List

Main Frame (BP) .....	19
Lower Housing Assembly .....	21
Chassis Assembly .....	23
Intermediate Frame Assembly .....	24
Cashbox Assembly .....	24

# SECTION 1: GENERAL INFORMATION

---

## INTRODUCTION

This manual contains information on installing, operating and maintaining Coinco's BillPro Series bill acceptors.

This manual is intended for owners, route operators and shop-level technicians as a primary source of information. Taking time to read this manual and becoming familiar with this information will help you obtain the best performance from your Coinco bill acceptor.

## MODELS

BillPro Series bill acceptors are self-contained units designed to work with MDB vendors. Listed below are some of the models available:

**BP2BX** BillPro bill acceptor, 2 bill acceptance (\$1 & \$5), Bottler mask & MDB interface only

**BP4BX** BillPro bill acceptor, 4 bill acceptance (\$1, \$5, \$10 & \$20), Bottler mask & MDB interface only

**BP4SX** BillPro bill acceptor, 4 bill acceptance (\$1, \$5, \$10 & \$20), Snack mask & MDB interface only

BP2BX and BP4BX bill acceptors are primarily used in cold drink vendors which use MDB interface. The BP4SX bill acceptor are primarily used in MDB snack, coffee or food machines.

BillPro units support MDB communication only.

## FOR YOUR RECORDS

A label indicating the model number and serial number is affixed to the back of the bill acceptor. Refer to the model and serial number whenever you call upon your Coinco Service Center for information or service. The first four digits of the serial number contain the manufacturing date code which indicates the beginning of the warranty period.

***EXAMPLE:** Serial number 260300135. First and second digits indicate the week of manufacture. The third and fourth digits indicate the year (the 26th week of 2003).*

## FEATURES

- Modular design
- Illuminated Inlet
- Flash programmable memory
- Exceptional acceptance rate
- Anti-jam software
- Flex stack bill box
- Center drive belt
- Scalloped bill path for wet bill acceptance
- State-of-the-art electronic logic system
- Programmable acceptance of the following bills: \$1, \$5, \$10 and \$20.
- Vandal resistant design protects against: saltwater, bill pullback, counterfeit bills.
- Utilizes standard mounting
- 34 V Multi-Drop Bus interface
- High impact, non-corrosive plastic construction
- Easily accessible bill path
- Self-diagnostics communicated via status light
- Manufactured and supported by Coinco.

## AFTER UNPACKING

After unpacking the unit, inspect it for any possible shipping damage. If the unit is damaged, notify the shipping company immediately. Only the co-signee (the person or company receiving the unit) can file a claim against the carrier for shipping damage. We recommend that you retain the original carton and packing materials to reuse if you need to transport or ship your acceptor in the future.

If the bill acceptor is being stored or used as a spare, always keep it in its shipping carton when not in use. This will keep it clean and offer the best protection for the unit.

## MAIN LOGIC BOARD ASSEMBLY

The main logic board contains the microprocessor which controls all the functions of the bill acceptor based on information from the vending machine, coin mechanism and various bill acceptor sensors.

Also contained on the main logic board are lower optic sensors and the power supply which receives its primary voltage from the vending machine. The 34 VDC (MDB) primary voltage is filtered and reduced for the main logic board.

# SECTION 1: GENERAL INFORMATION

## Dimensions and Specifications

Figure 1

**Power Requirements**

22 to 45 VDC  
 0.2 Amp average standby  
 2.5 Amp average operating

**Operating Temperature**

0°F to 150°F  
 -18°C to 65°C

**Storage Temperature**

-22°F to 165°F  
 -30°C to 74°C

**Relative Humidity**

5% to 95% non-condensing

**Physical Weight in Shipping Carton**

4 pounds

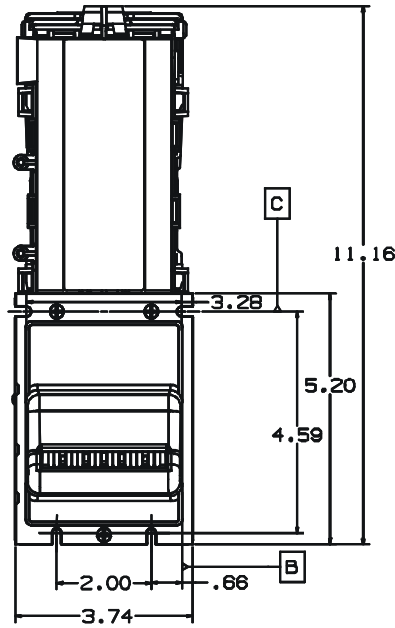

**BP2BX, BP4BX**

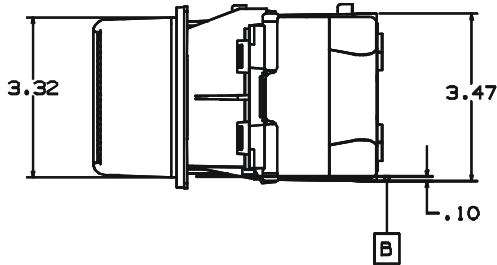

**BP4SX**

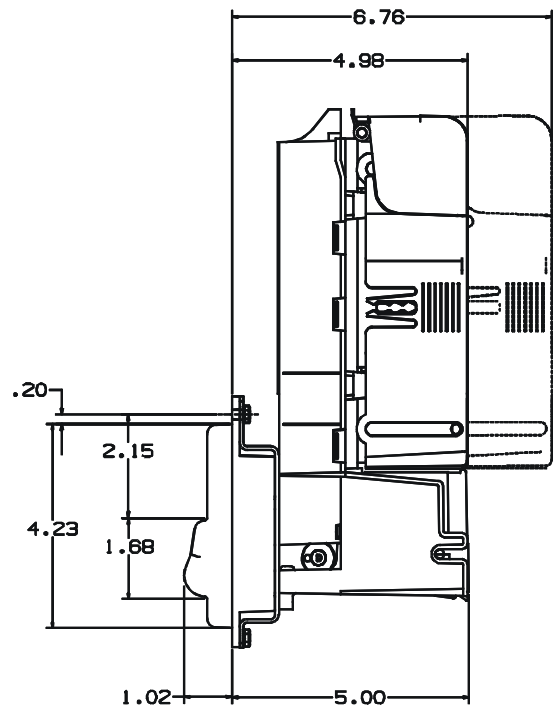
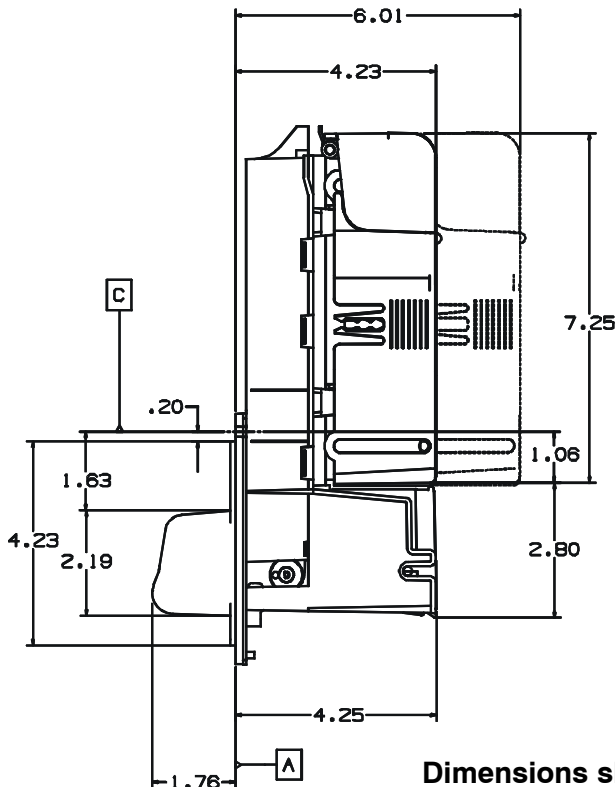
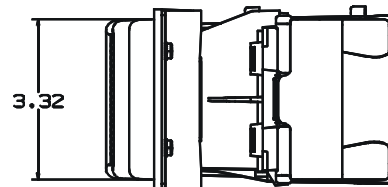

Dimensions shown in inches

**OPTION SETTINGS**

The eight different configuration options and the order in which they are stored in the bill acceptor are as follows:

- \$1 accepted with high security disable
- \$1, \$5 accepted with high security disable
- \$1, \$5, \$10 accepted with high security disable \*
- \$1, \$5, \$10, \$20 accepted with high security disable \*
- \$1 accepted with high security enable
- \$1, \$5 accepted with high security enable
- \$1, \$5, \$10 accepted with high security enable \*
- \$1, \$5, \$10, \$20 accepted with high security enable \*

Configuring the bill acceptor for bill enabling and security is accomplished using the anti-cheat lever and the illuminated inlet. The anti-cheat lever is used to enter configuration programming mode, scroll through all possible configuration options and select the required configuration. The illuminated inlet provides feedback to the user during the configuration process by displaying a pattern that corresponds to each configuration option available.

\* Options available for BP4 only.

**Lower Housing**

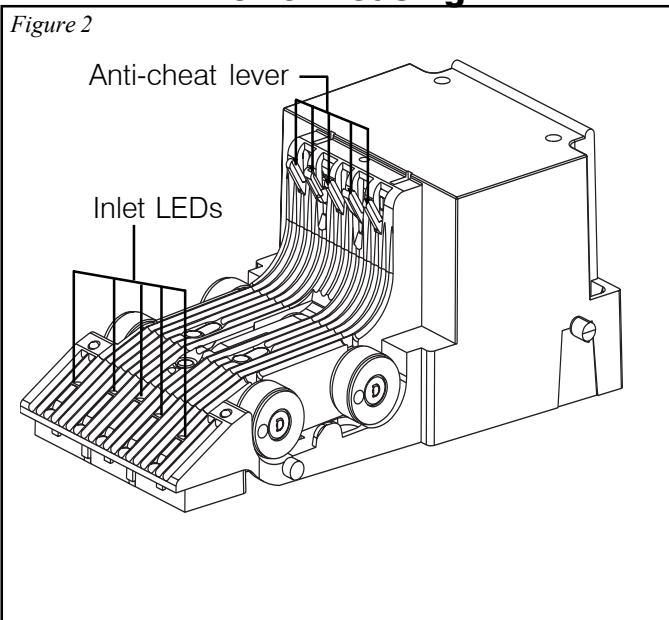

**SETTING THE CONFIGURATION OPTIONS (see Figure 2)**

- Remove the lower housing.
- With power applied, depress and release the anti-cheat lever five times, holding it down for a half a second each time.
- Once in the configuration mode, depress and release the anti-cheat lever one time to scroll to the next configuration option. Continue depressing and releasing the anti-cheat lever until the desired option is reached.
- Once the desired option is displayed, depress and hold the anti-cheat lever until the unit exits the configuration mode (approximately 3 seconds). The new configuration setting will flash 3 times to confirm the setting.
- Replace the lower housing.
- Test unit to insure proper set-up.

**INSTALLING THE BILL ACCEPTOR**

1. Remove the vending machine's power.
  2. Install the BillPro Series bill acceptor into the mounting hole of the vending machine using the appropriate hardware (NOT INCLUDED).
- NOTE: Should additional mounting hardware be required, please contact your local Coinco office or machine manufacturer*
3. Connect the BillPro MDB interface harness to the the vending machine and coin changer.
  4. Restore power to the vending machine (illuminated inlet will begin to flash and stacker motor will cycle upon power-up).
  5. Observe that the power indicator light, on the back of the lower housing, is ON continuously. If the light is OFF or blinking, check the following:
    - Power to machine
    - Machine disabling unit
    - Bill acceptor harness
    - Machine does not have credit already established
  6. With the vend price set below one dollar, insert a one dollar bill.
  7. Verify the dollar bill is accepted and stacked into the bill box.
  8. Verify a one dollar credit has been established.

**Inlet Leds**

This example shows \$1 enable and high security disable

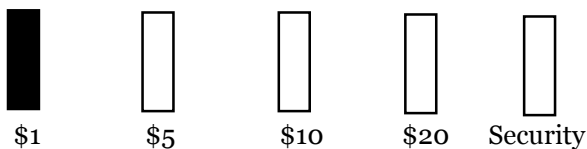

This example shows \$1 enable and high security enable

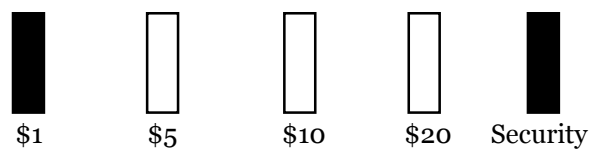

## SECTION 3: OPERATION

---

### **BILL RECOGNITION**

When a bill is inserted into the bill acceptor and it blocks the left and right alignment sensors as well as the center optic sensor, the transport motor begins to run.

### **BILL VALIDATION**

From the time the transport motor begins to run until the trailing edge of the bill leaves the alignment sensors, optical and magnetic sensors send information to the microprocessor to determine the validity of the bill.

### **BILL STACKING AND CREDIT**

If the bill is determined to be authentic, it is transported to the stack position. Once the sensors of the lower housing's anti-pullback lever signals the microprocessor that the bill is in the stacking position, the stacker motor runs and credit is given.

### **BILL REJECTION**

If the bill is determined to be invalid, the wrong denomination or the anti-pullback levers are active when the bill is determined to be in the stack position, the transport motor will reverse returning the bill to the customer.

### **COMPONENT EXPLANATION (see Figure 3)**

#### **Bill Transport and Stacking**

The bill transport system is composed of a motor and gearcase assembly and two sets of pulleys and belts. When the transport motor is energized, it pulls the bill in by sandwiching it between the lower housing rollers and the chassis belts. During the validation process, the bill is transferred from the lower housing rollers and chassis belts to the intermediate frame and rollers.

The bill stacker is composed of a motor and gearcase assembly and a pusher plate assembly. When the bill is transported past the anti-pullback levers into the stacking position, the stacker motor energizes driving the pusher plate, which in turn, pushes the bill into the bill box.

#### **Left and Right Alignment Sensors**

The left and right alignment sensors send information to the microprocessor to ensure that the bill is the right width and that it is being fed in correctly.

#### **Center Optic Sensor**

The center optic sensor informs the microprocessor that the bill is ready to be transported if the information from the alignment sensors is correct.

#### **Left and Right Optic Sensors**

The left and right optic sensors and associated circuitry perform various optical checks on the bill and send that information to the microprocessor for bill validation.

#### **Magnetic Sensor**

The magnetic sensor and its associated circuitry performs checks on the magnetic properties of the bill and sends that information to the microprocessor for bill validation.

#### **Anti-Pullback Lever**

The lower anti-pullback lever is optically monitored to tell the microprocessor when the bill has entered the stack position or if an attempt to defraud the unit is taking place.

#### **Stacker Home Sensor**

The stacker home sensor is an optical sensor that informs the microprocessor of the position of the stacker pusher plate.

#### **Encoder Sensor**

Connected to the transport motor is an encoder wheel which is optically monitored to determine the speed of the transport motor and to determine the position of the bill in the bill path.

Figure 3

**Component Explanation**

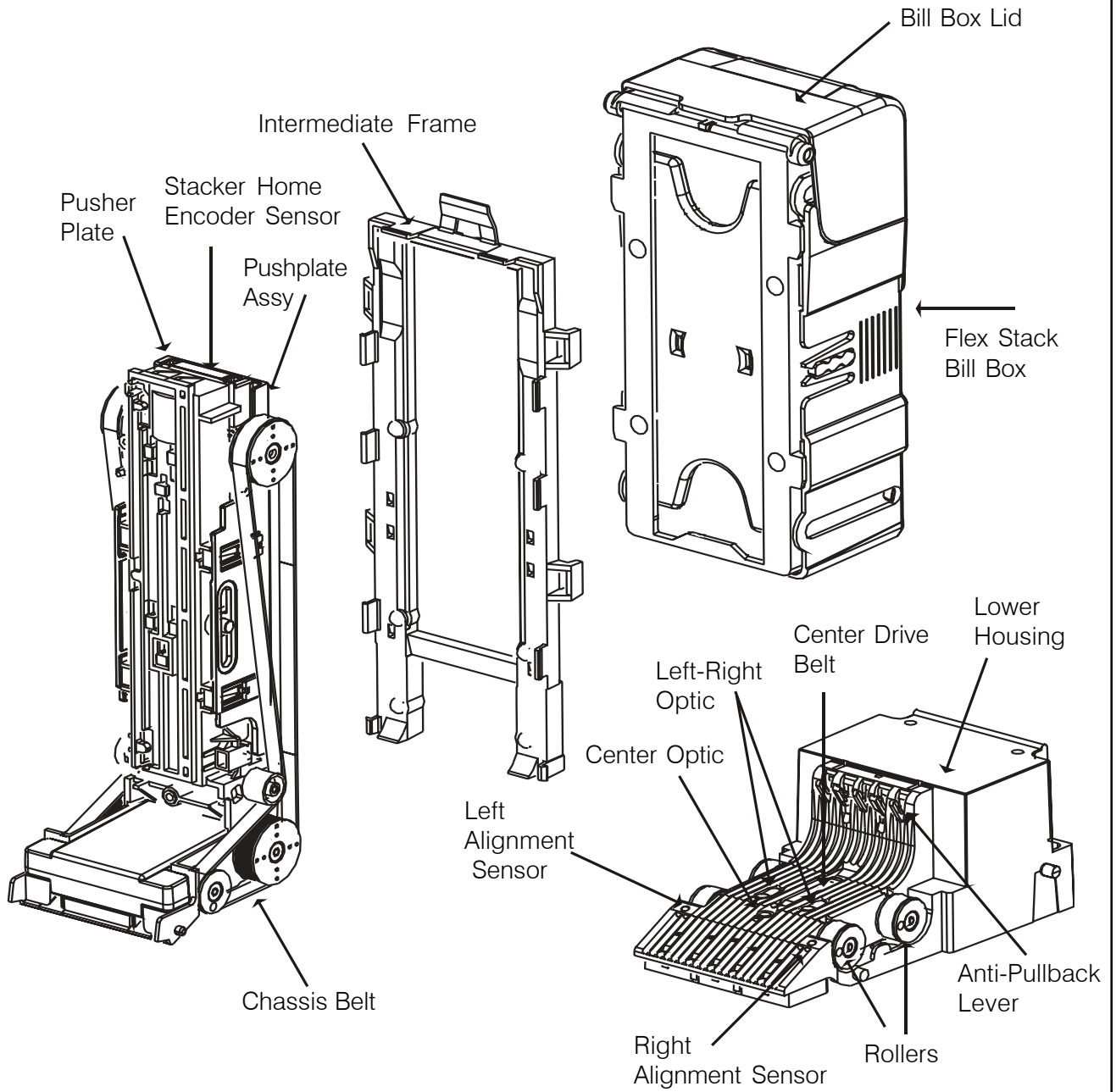



**Interconnection**

**BP** Figure 4

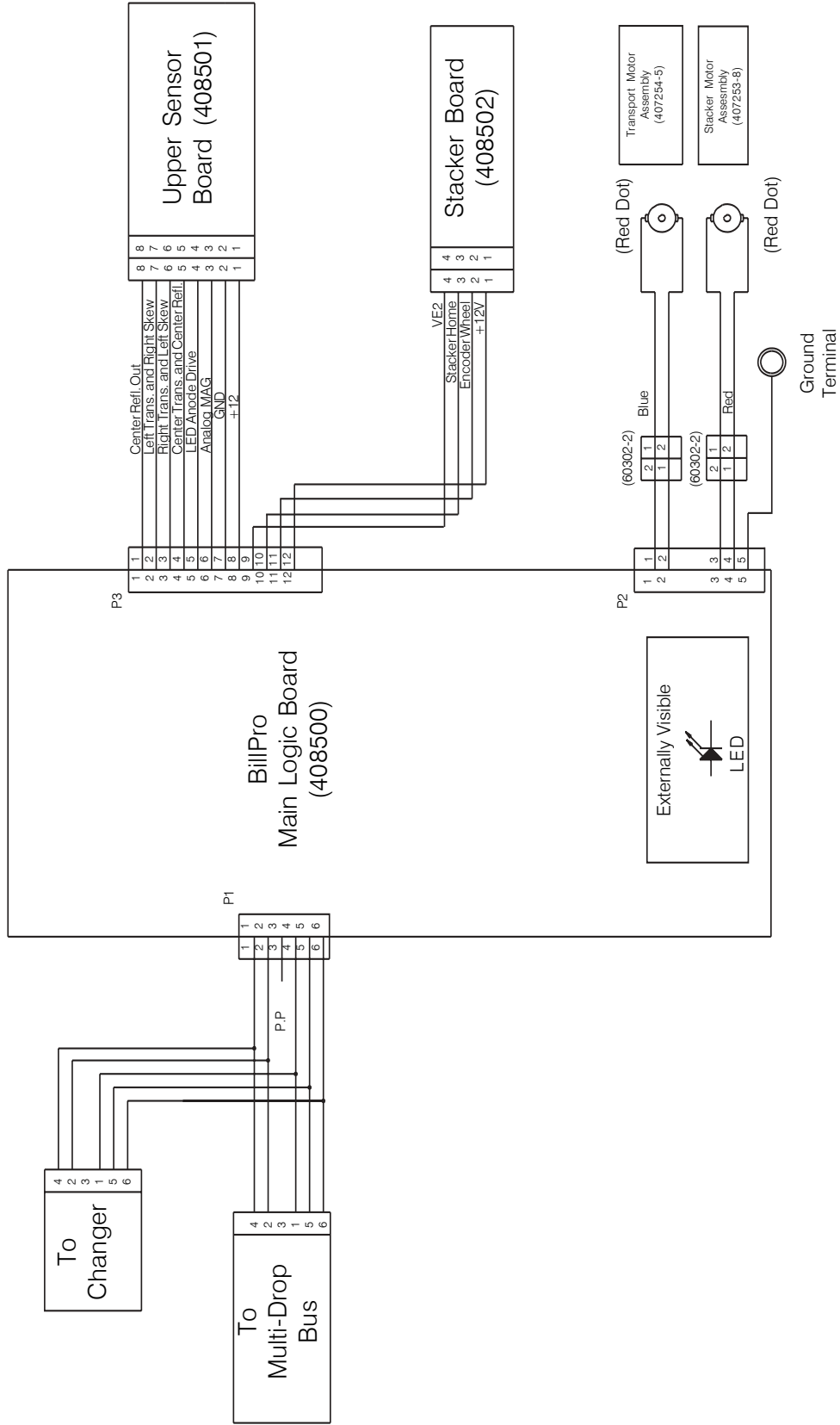

## SECTION 4: MAINTENANCE

### DISASSEMBLING THE BILLPRO

#### Removing the Bill Box (see Figure 5)

Push the bill box tab forward while sliding the bill box up.

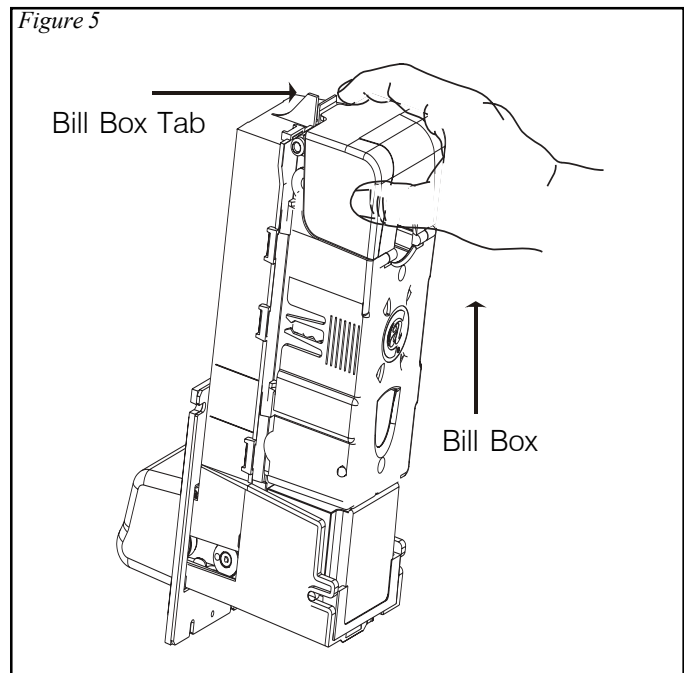

#### Removing the Lower Housing (see Figure 6)

To remove the lower housing, push the locking tab on the bottom of the bill acceptor and pull the lower housing to the rear.

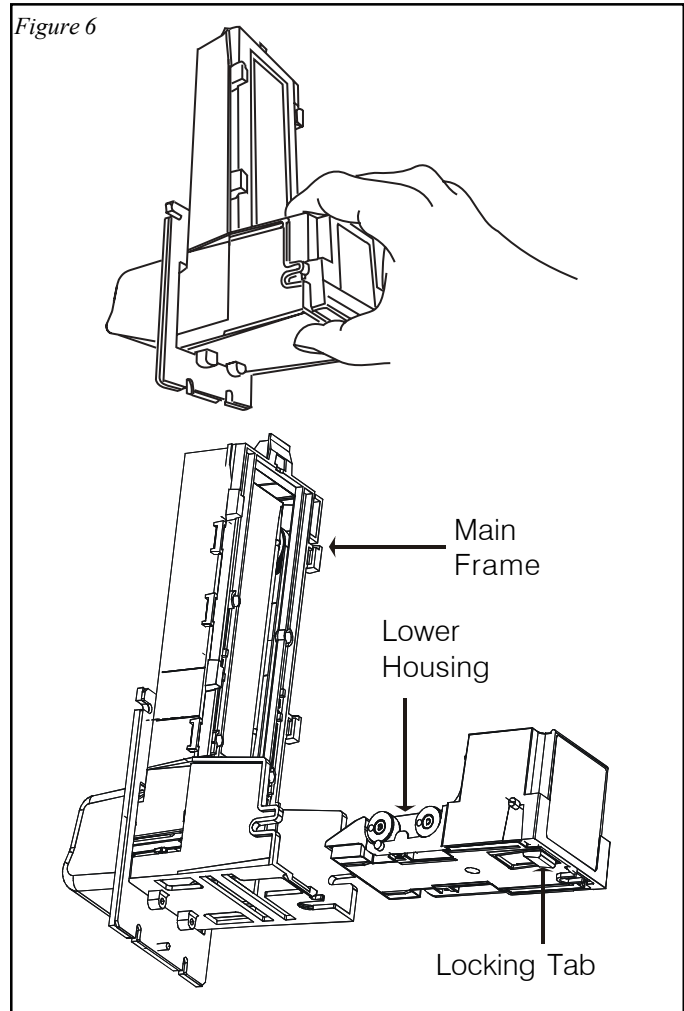

## SECTION 4: MAINTENANCE

### Removing the Intermediate Frame (see Figure 7)

Using a small straight tip screwdriver, free the ten locking tabs which secure the intermediate frame to the main frame and remove the intermediate frame.

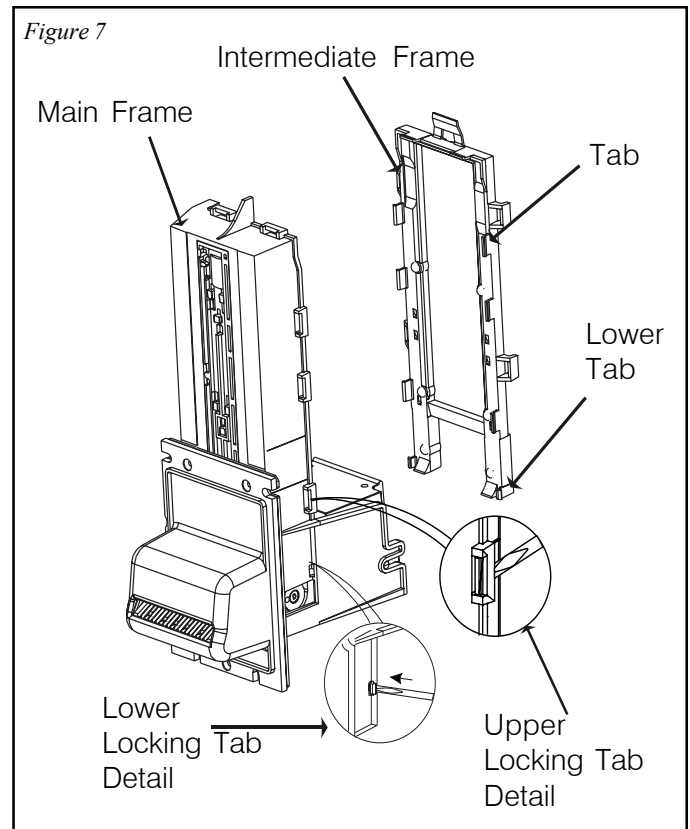

### Removing the Inlet Mask (see Figure 8)

Using a Phillips screwdriver, remove the three screws that secure the mask to the mounting frame.

### Removing the Mounting Frame and Static Grounding Spring (see Figure 8)

Using a Phillips screwdriver, remove the screws that attach the mounting plate and grounding spring to the main frame.

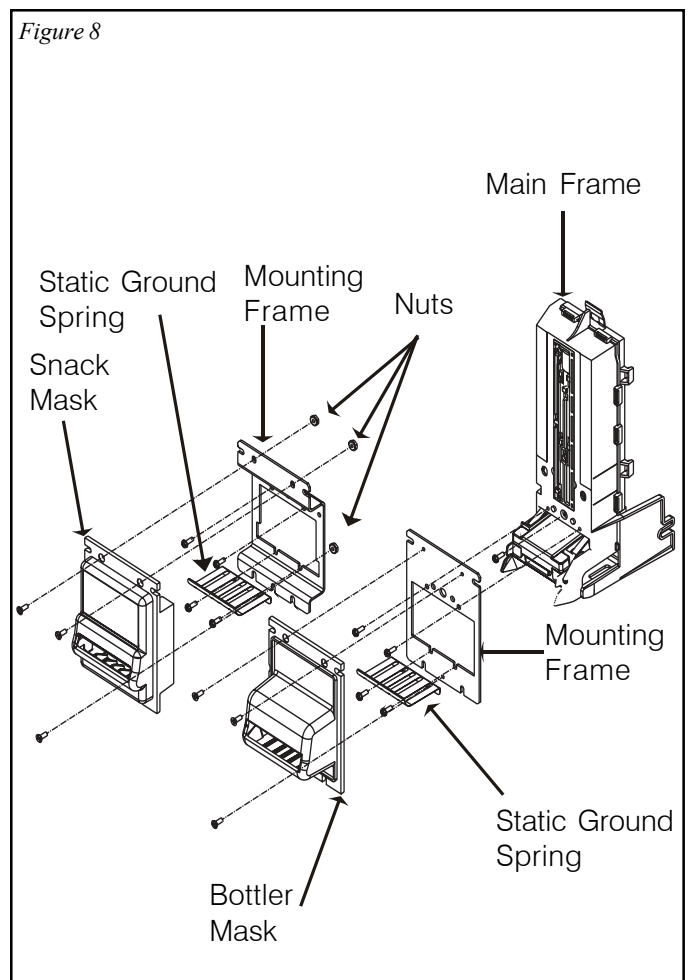

## Removing the Upper Sensor Board from the Chassis (see Figure 9)

Remove upper PCB cover by unsnapping from front. Using a small Phillips screwdriver, remove two screws securing the upper PCB to the upper enclosure. Unplug the chassis harness from the upper sensor board. Lift board straight up and then forward to remove.

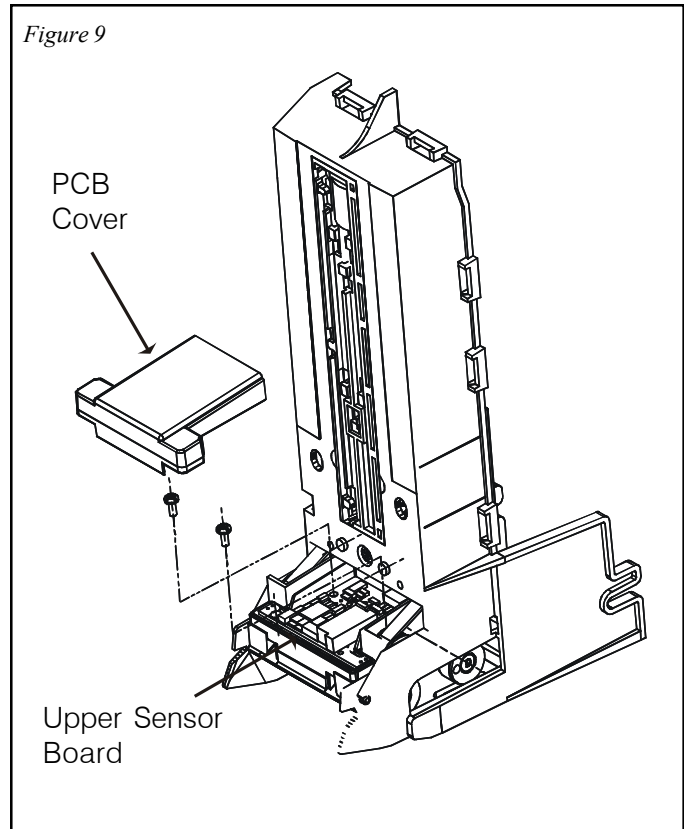

## Removing the Chassis from the Main-frame (see Figure 10)

Remove the Phillips screw securing the chassis to the main frame. Spread the main frame apart to release the two locating pins of the chassis from the main frame then pull down on the chassis. Carefully feed the chassis harness through the opening in the main frame. Pull the chassis out through the lower main frame opening.

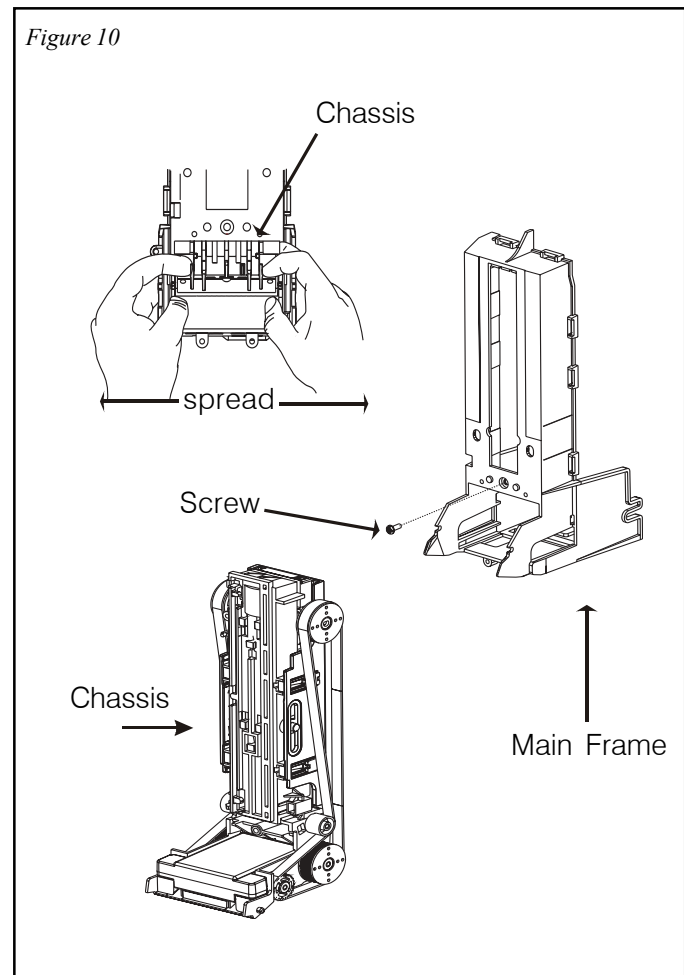

## SECTION 4: MAINTENANCE

### DISASSEMBLING THE CHASSIS

#### Removing the Pusher Plate from the Chassis (see Figure 11)

Remove the pusher plate from the stacker gear box assembly by slightly spreading the pusher plate until it clears the stacker motor cam assembly. Pull the pusher plate straight out until the locking tabs of the stacker slides catch the chassis. Using a small screwdriver, release the four tabs and remove the pusher plate.

Figure 11

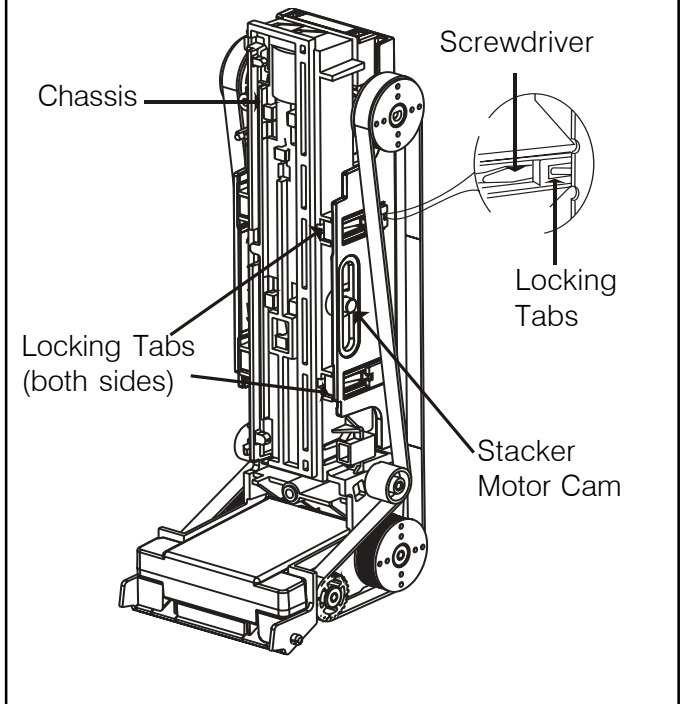

#### Removing the Encoder/Sensor Housing Board Assembly (see Figure 12)

Remove sensor housing by tilting up and away from transport motor gear case assembly, then pull straight out. Unplug harness connection.

Figure 12

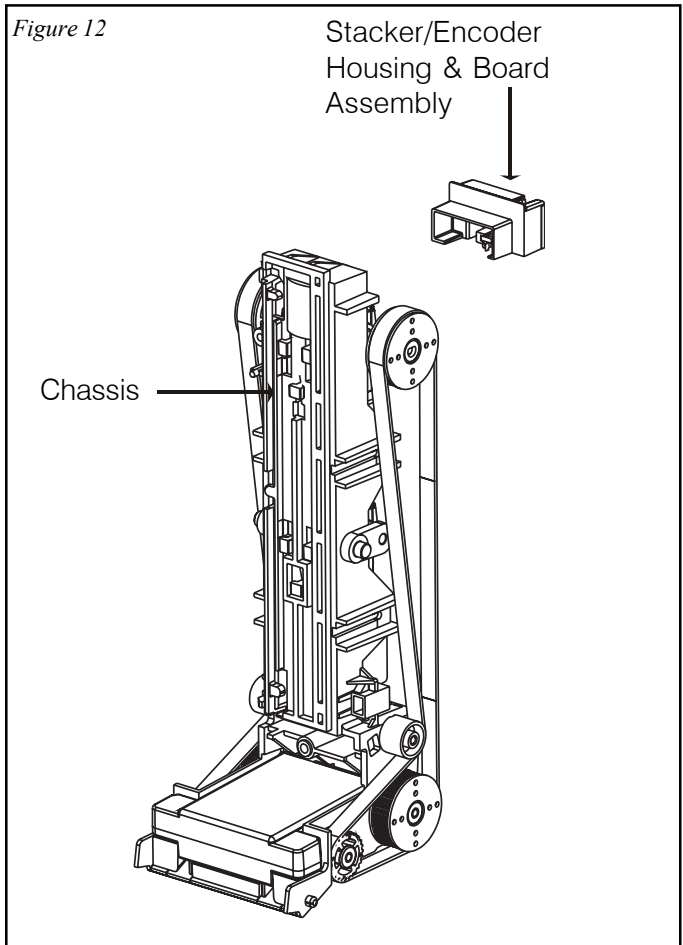

**Removing the Chassis Belts and Pulleys (see Figure 13)**

Compress the belt tensioning spring by pressing down on the transport motor and gear case assembly and remove the belts. Slide the pulleys off the lower shafts to prevent them from falling off.

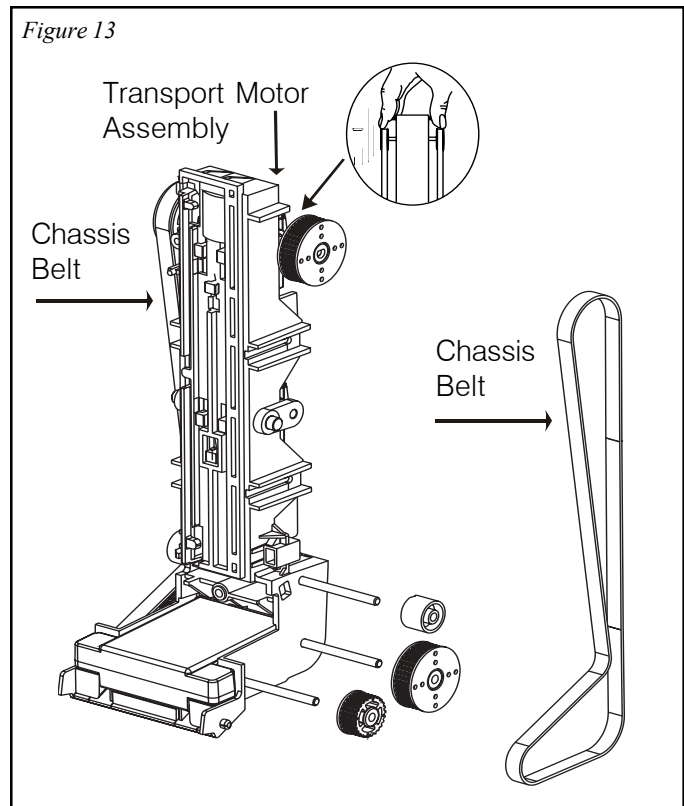

**Removing the Transport and Stacker Motor Assemblies (see Figure 14)**

Unplug motor wires from two connectors located on each side of chassis. Compress the belt tensioning spring by pushing up on the stacker motor and gear case assembly until the three locking tabs of the gear case can be freed from their mating slots in the chassis. Remove the stacker motor and gear case assembly along with the tensioning spring. Slide the transport motor and gear case assembly down until its three locking tabs are freed from their mating slots on the chassis.

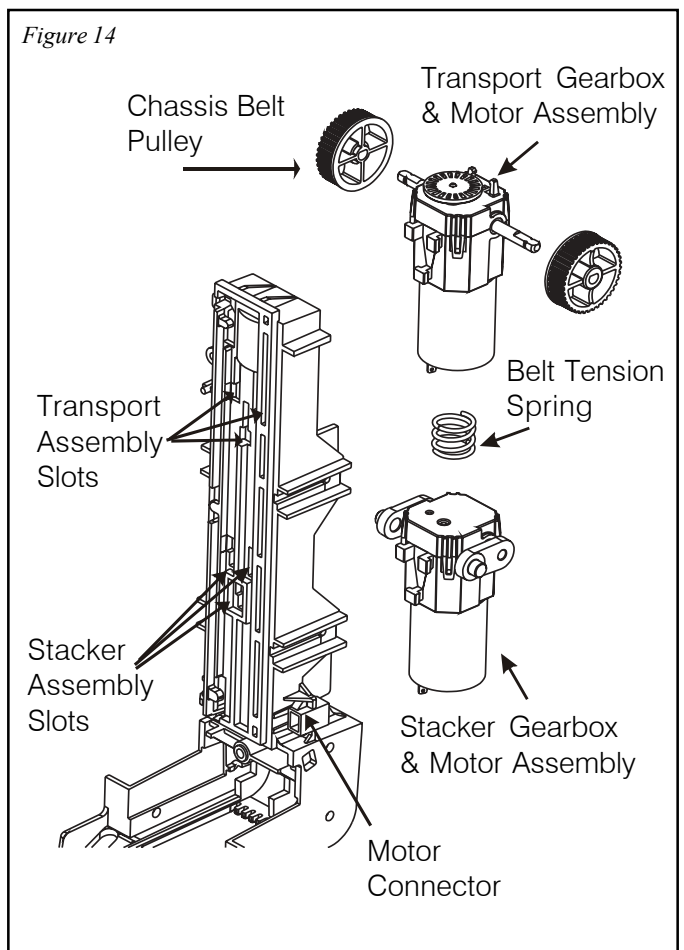

## SECTION 4: MAINTENANCE

### DISASSEMBLING THE LOWER HOUSING

#### Removing the Printed Circuit Board (see Figure 15)

Using a small straight screwdriver, pry up at the two outer tabs on the lower PCB cover. Pivot the front of the cover up and then slide forward. Lift the board out by gently pulling up on the harness.

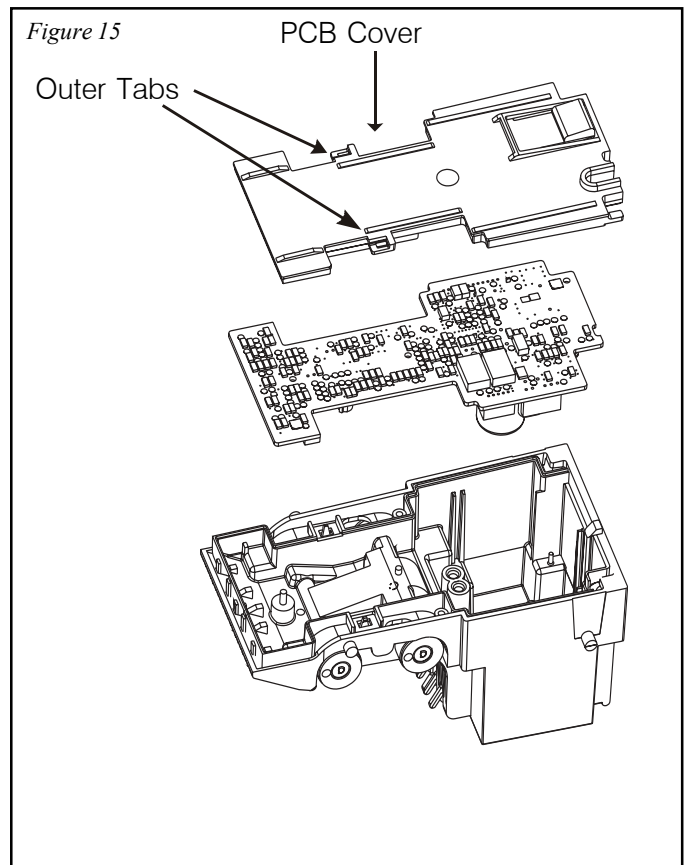

#### Removing the Mag Roller and Spring (see Figure 16)

Lift lower enclosure out of the lower housing.

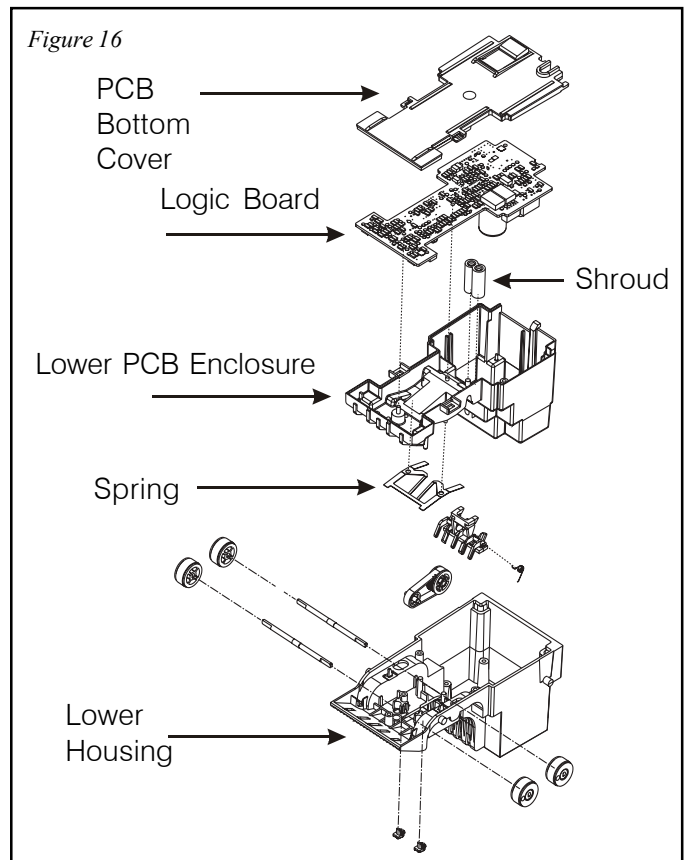

**Removing the Lower Housing Anti-Pullback Lever and Spring (see Figure 17)**

Using a small drift or Phillips screwdriver, depress the locking tab in the small hole in top of the lower housing. At the same time, insert a small standard blade screwdriver into the center slot and push the anti-pullback assembly back out of the retaining tabs.

Remove the anti-pullback lever from its mount by releasing the locking tabs. Pay close attention to the placement of the spring to assure its correct position on reassembly.

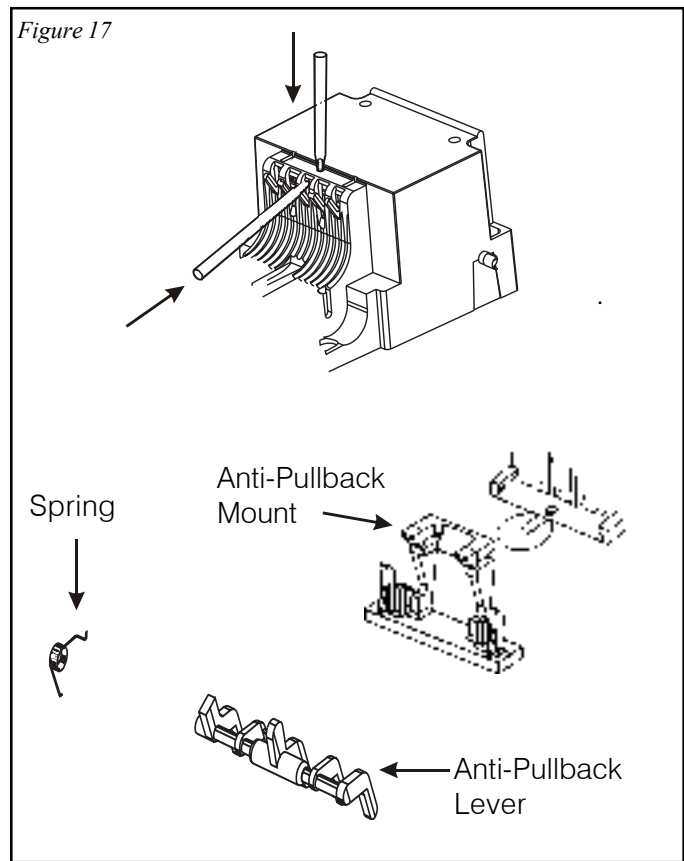

**Removing the Lower Housing Rollers and Pulleys (see Figure 18)**

Slide the front pulleys off the shaft. To remove the center belt, slide the back pulleys off the shaft. Gently tap the back shaft with a small hammer until the shaft splines are free from the center pulley.

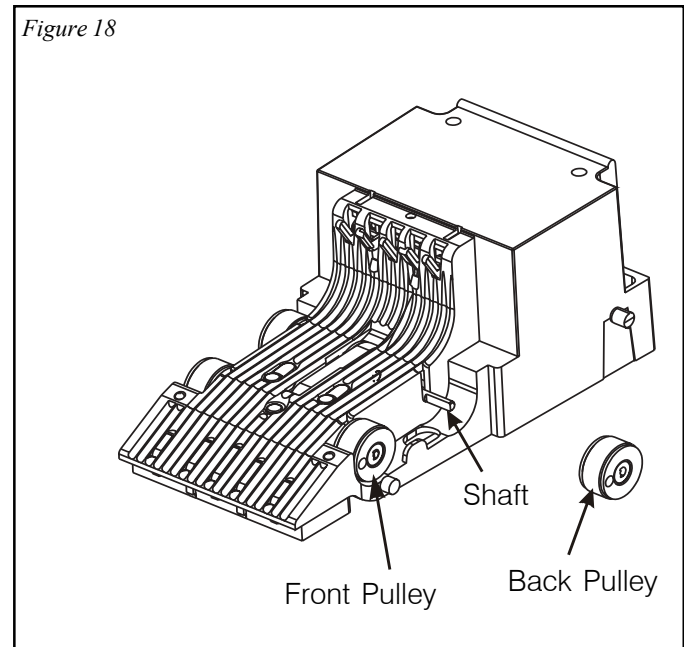



## SECTION 4: MAINTENANCE

---

### BILLPRO CLEANING MAINTENANCE PROCEDURE

*NOTE: Petroleum-based cleaners and freon-based propellants can damage plastic and some electronic components. Scouring pads and stiff brushes may harm the circuit boards and mar the plastic. These items should never be used when cleaning the BillPro bill acceptor.*

The BillPro should be cleaned every 20,000 bills or every two years (or as needed, depending on the environmental conditions of the location). Dust can be removed with a soft brush or cloth or it can be blown out using compressed air.

#### Procedure

1. Disconnect power from the bill acceptor.
2. Remove the bill box and use a soft cloth to wipe any dust from around the intermediate frame and stacker plate.
3. Remove the lower housing.
4. Using compressed air or a soft brush, blow or brush the dust off of the optic sensors.
5. Remove dust from around the rollers on the lower housing and the sensors on the upper sensor board. The upper sensors are located directly above the lower housing sensors when the lower housing is installed.
6. The bill path can be further cleaned of any dirt or oil by using a soft cloth moistened with a mild soap and water solution.
7. Clean the magnetic head with a cotton swab and isopropyl alcohol.
8. Remove dust from the transport belt areas and any other places of build up.
9. Once the lower housing is dry, place it back into the mainframe making sure the tab on the bottom locks into place.
10. Remount the bill box.
11. Apply power and insert bills to verify the unit is functioning properly.

### BILLPRO CLEANING PROCEDURE FOR SALT WATER POLLUTED UNITS

*NOTE: Petroleum-based cleaners and freon-based propellants can damage plastic and some electronic components. Scouring pads and stiff brushes may harm the circuit boards and mar the plastic. These items should never be used when cleaning the BillPro bill acceptor.*

#### Procedure

1. Remove power from the bill acceptor.
2. Remove the bill acceptor from the vending machine.
3. Open the bill box lid and verify that the stacker plate is in the standby/home position. If it is not in the home position, apply power and observe that the stacker plate returns home.
4. Remove the bill box.

*WARNING: If moisture is present, allow the unit to dry thoroughly before applying power to avoid possible shock hazard. If the stacker plate does not return to the home position, remove power and carefully remove the bill box to avoid damaging the bill box and/or stacker plate.*

5. Remove the lower housing.
6. Remove the bottom cover of the lower housing.
7. Run hot water (110°-140°F) over the lower housing from the top. Using a soft brush, gently clean any salt residue. Use a soft, absorbent cloth to clean residue off the lower housing. Allow the unit to dry for 24 hours before applying power.
8. Remove the front mask. Using hot water and a soft brush, clean the front mask, upper sensor board cover and main frame anti-pullback levers.

*CAUTION: The motors are not protected from water, therefore the unit must be held in a manner that prevents water from running over them.*

9. Verify the anti-pullback levers move freely and that the spring returns them to their extended position.
10. Allow the unit to dry thoroughly.
11. Clean the magnetic head using a swab and isopropyl alcohol.
12. Replace the front mask.
13. Replace the lower housing cover.
14. Place the lower housing into the main frame.
15. Remount the bill box.
16. Apply power and insert bills to verify the unit is functioning properly.

## INTRODUCTION

The Troubleshooting Guide on this page is intended to help locate problems within the bill acceptor. If a bill acceptor cannot be repaired by following this guide, return the unit to the nearest Coinco Service Center for repair along with a complete description of the problem you are having with the bill acceptor.

Logic troubleshooting minimizes the time spent in removing and replacing parts that are not defective. Some failures are caused by minor problems such as dirt or loose/faulty connections. Please check the following before replacing any parts:

- Clean any dirt or dust from the bill path.
- Vending machine is not disabling unit.
- Connectors are inserted correctly.
- Connector pins are not bent or broken.
- All wires are properly secured.

## BILLPRO DIAGNOSTIC CODES

Troubleshooting can be done by reading the number of flashes or blinks of light from the LED at the bottom of the BillPro bill acceptor. Refer to Figure 19.

Figure 19

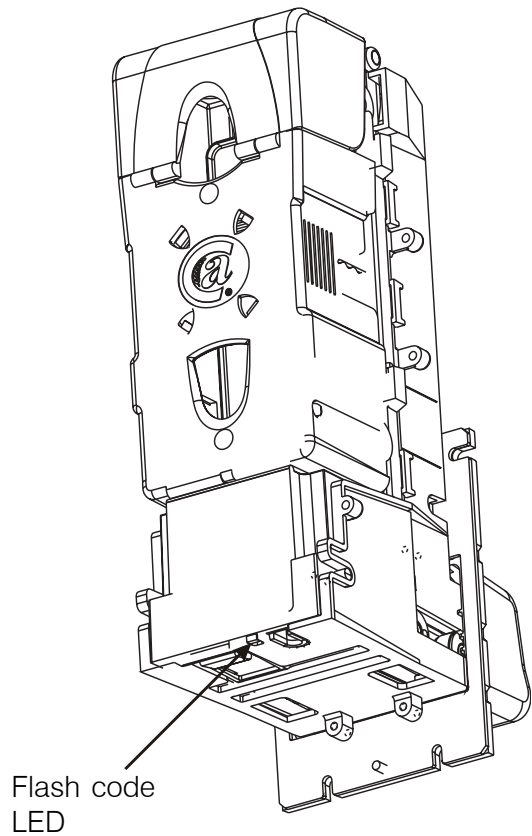

### Flash Codes

The BillPro supports the following flash codes for troubleshooting the unit in the field.

Flash Code	Error Condition
1	Check bill box
2	Check/Clean bill path
3	Return for service

**NOTE:** A scrolling light, in the illuminated inlet, indicates normal operation. If all LEDs are not illuminated then, the unit has been disabled by the Vending Machine Controller.

**MAIN FRAME**

BillPro

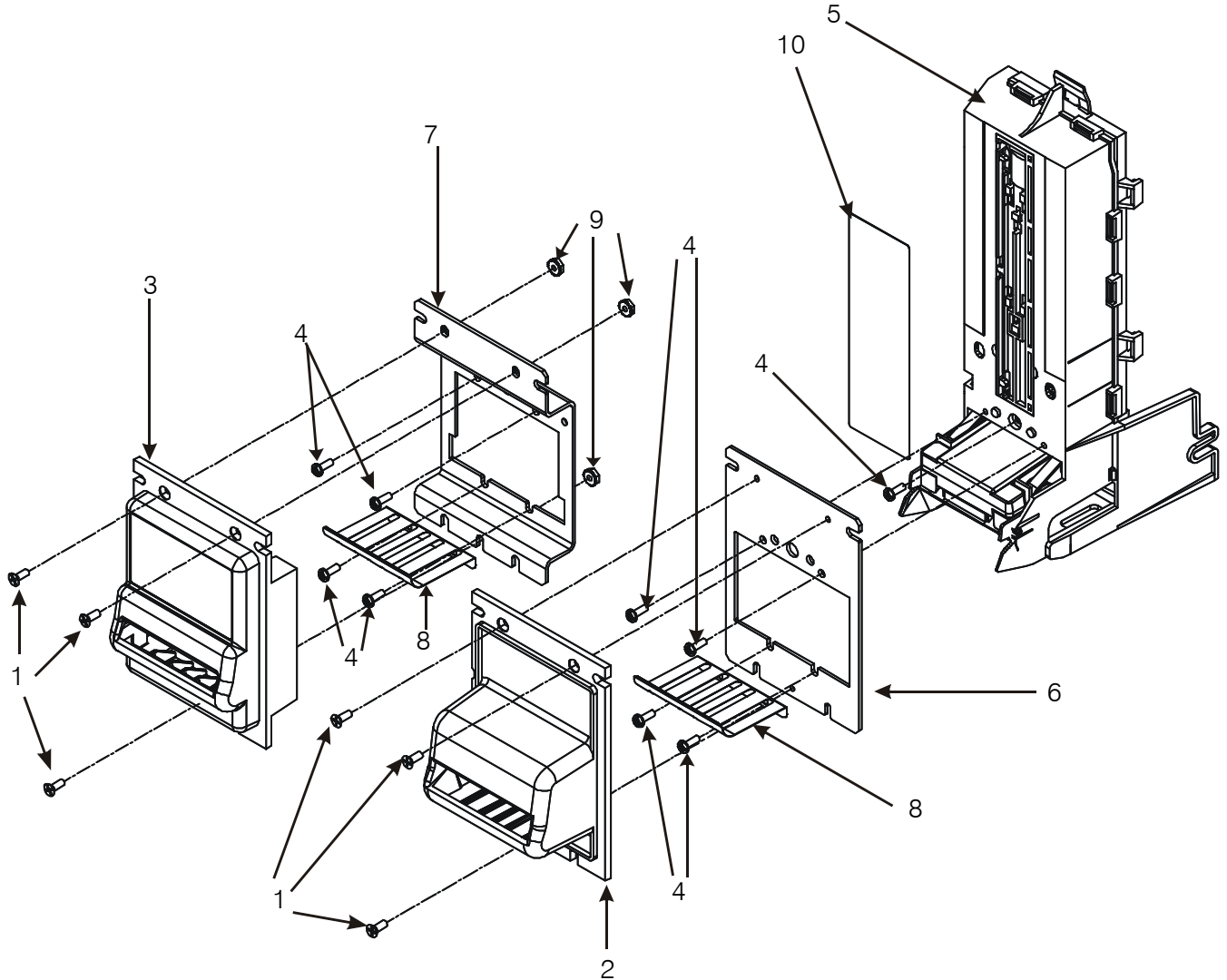

ITEM NO.	PART NO.	DESCRIPTION	QTY.	NOTES
1	921401-2	Screw	3	
2	925305	Bottler Mask	1	
	408576	Security Bottler Mask	1	Used on BP4BXM
3	925511	Snack Mask	1	
4	345-6R6	Screw	5	
5	920807-6	Main Frame	1	
6	925682	Mounting Frame, Bottler	1	
7	925681	Mounting Frame, Snack	1	
8	925290	Grounding Spring	1	
9	438-6	Hexnut & Lock Washer	3	6-32
10	925505	BillPro Front Label	1	

# SECTION 6: PARTS LIST

## LOWER HOUSING ASSEMBLY

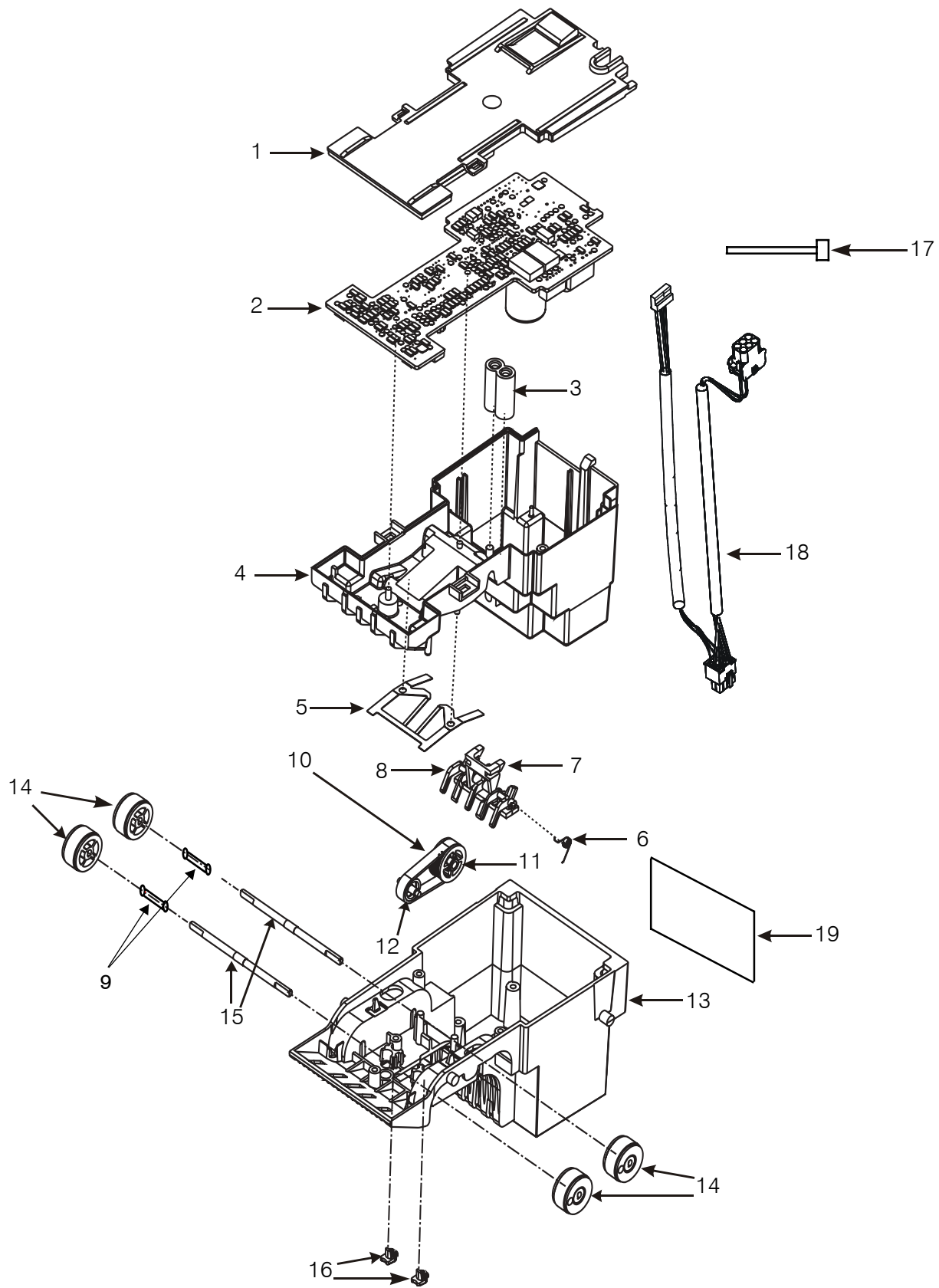

**SECTION 6: PARTS LIST**

<b>ITEM NO.</b>	<b>PART NO.</b>	<b>DESCRIPTION</b>	<b>QTY.</b>	<b>NOTES</b>
1	925285	Lower Cover	1	
2	409500S	Logic PCB Assy.	1	
3	925347	Anti-Pullback Light Pipe Shroud	1	
4	925284	Lower Enclosure	1	
5	923102	Spring	1	
6	920889	Anti-Pullback Lever Spring	1	
7	920819-1	Anti-Pullback Lever Mount	1	
8	925343	Anti-Pullback Lever	1	
9	927927	Teflon Tube	4	
10	923403	Center Belt	1	
11	408056	Pulley & Hub Assy.	1	
12	923101	Idler Roller	1	
13	920806-6	Lower Housing	1	
14	408165-2	Pulley & Tire Assy.	4	
15	923080	Drive Shaft	2	
16	925357	Sensor Plug	2	
17	906303	Cable Tie	1	6"
18	408420-1	MDB Cable Assy.	1	
19	925208-1	ID Label	1	
20	925440	Flash Code Decal	1	Not Shown; Place on top side of housing

**CHASSIS ASSEMBLY**

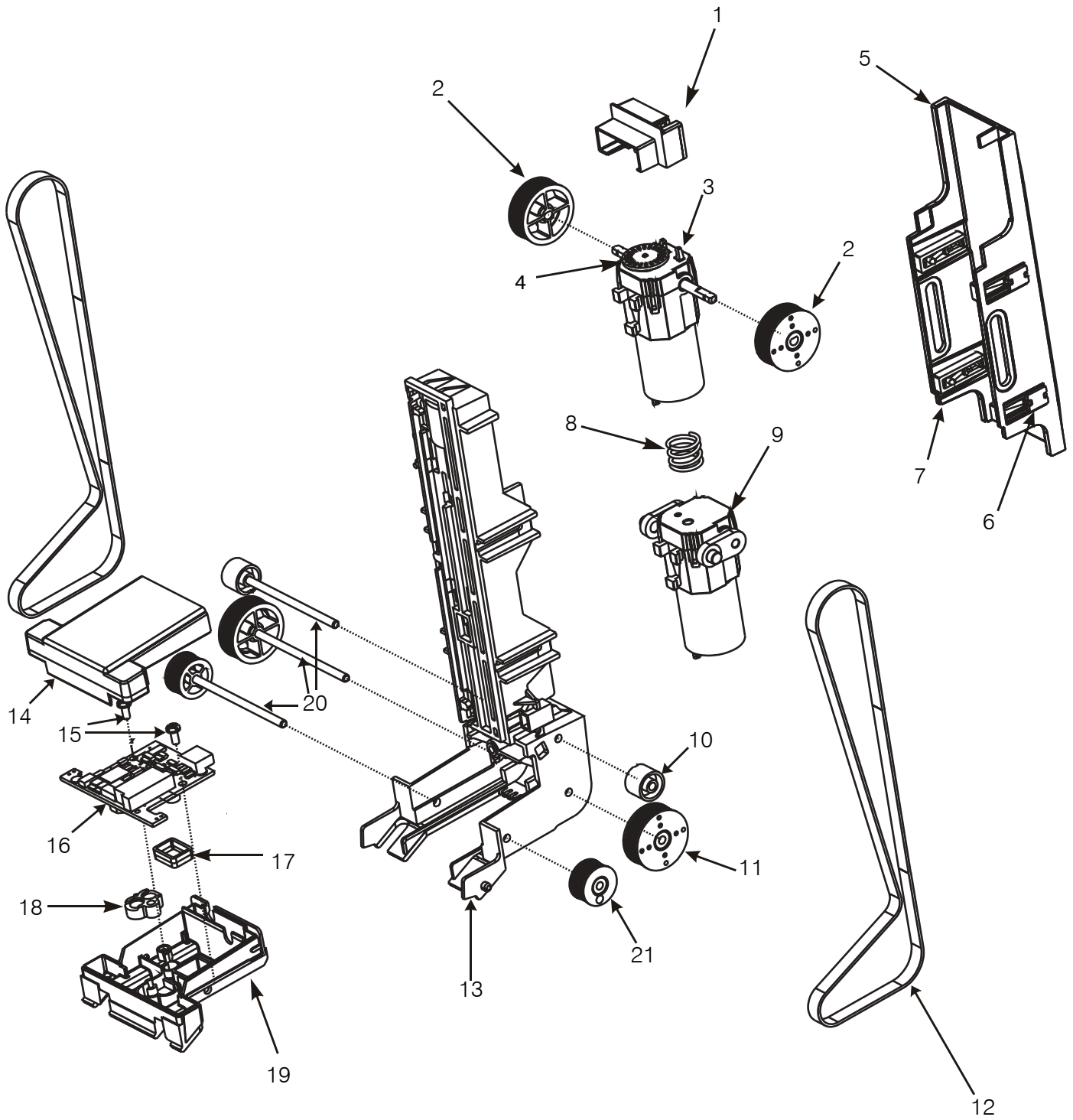

**SECTION 6: PARTS LIST**

<b>ITEM NO.</b>	<b>PART NO.</b>	<b>DESCRIPTION</b>	<b>QTY.</b>	<b>NOTES</b>
1	409502	Stacker/Encoder Board Assy.	1	
2	408054	Upper Transport Pulley & Hub Assy.	2	
3	408586-4	Transport Motor Gearbox Assy.	1	Includes #4
4	920000-3	Encoder Wheel	1	
5	408594	Stacker Pushplate Assy. BillPro	1	Includes #6 & #7
6	920836	Stacker Cap	4	
7	920833-1	Stacker Slide	4	
8	925202	Belt Tension Spring	1	
9	408585-4	Stacker Motor Gearbox Assy.	1	
10	920829-1	Idler Pulley	2	
11	408055	Lower Transport Pulley & Hub Assy.	2	
12	921403	Chassis Belt	2	Black
13	408527	Chassis With Connectors	1	Includes 925234 with connectors
	925234	Chassis	1	Without connectors
14	925236	Upper Sensor Cover	1	
15	345-4R4	Screw	2	#4 X 1/4 PH plastite
16	409501	Upper Sensor Board	1	
17	925507	Maghead gasket	1	
18	920893-2	Sensor Mount	1	
19	925235	Upper Sensor Enclosure	1	
20	920040	Wheel Shaft	3	
21	408057	Inlet Pulley & Hub Assy.	2	
22	408230	Harness	1	not shown
23	901358	4" Cable Tie	1	not shown

## SECTION 6: PARTS LIST

### INTERMEDIATE FRAME ASSEMBLY (408261)

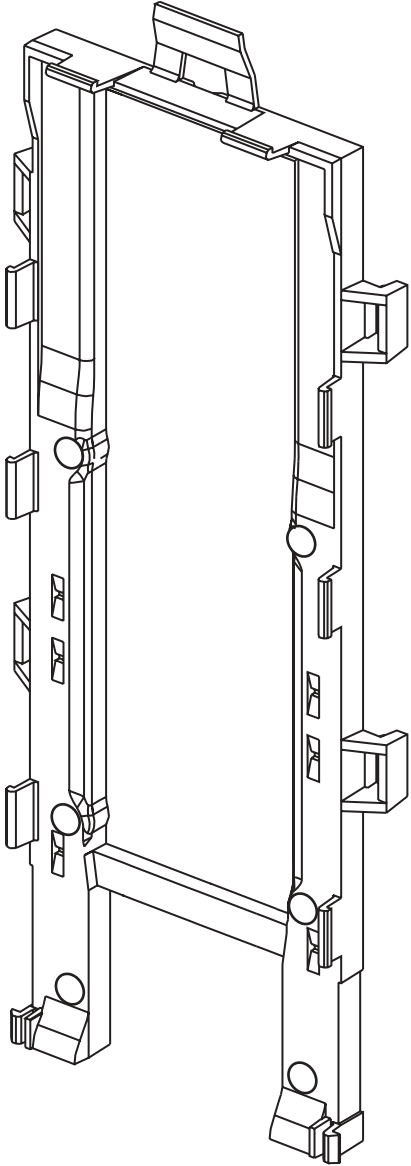

### Flex Stacker (408552)

