

Parallel Flow Hopper

Model: 18-Parallel
Product Manual
Pre-release
Version 0.5 / January 2011



 SUZOHAPP

Antonie van Leeuwenhoekstraat 9
3261 LT Oud-Beijerland
The Netherlands

Phone : +31(0)186-643333

Fax : +31(0)186-643322

Email : info@suzo.com

Web : www.suzo.com

Inhoud

1. Introduction.....	2
2. Change hopper for different coin sizes.	4
2.1. Hopper disassembly.....	4
3. Parallel protocol.....	5
3.1. Parallel protocol selection	5
3.2. Jumper settings.....	5
3.3. logic control signal active low.....	6
3.4. logic control signal active high	6
3.5. direct (power) control	6
3.6. pulsed control mode.....	6
4. In-Line configuration.....	7
5. Interface description	8
5.1. Parallel Connector Pinout	8
5.2. Coin Jams during payout	9
5.3. Power failures	9
5.4. Level sensing	9
5.5. Coin exit output	10
5.6. Error output	11
6. Electronics.....	12
6.1. specification Electrical, Timing and Environmental Specifications	12
7. Warranty.....	13
7.1. Your warranty.....	13
7.2. Conditions	13
8. Dimensions.....	14
8.1. General dimensions	14
8.2. Medium and large Extensions.....	14
Revision History.....	15

1. Introduction

The Flow hopper is a new and innovative addition to the Suzo-Happ range of hoppers. This through hole hopper has been re-engineered and the result is an improvement over existing hoppers in its performance. The Flow hopper is suitable for many applications such as: Vending, Parking, Change, Amusement and Gaming machines. Made from extremely strong, wearing resistant plastics in combination with state of the art electronics resulting in low cost of ownership.

The Flow hopper is available in two interfaces. Standard parallel interface or ccTalk serial interface.

Extra attention has been paid to hopper fraud attempts. Tampering the coin exit output by shorting it to a high level voltage will be detected. Hopper will stop as soon as a coin passes the opto sensor and will generate an error.

Tampering the opto coin detection sensor is shielded. The IR-receiver is not directly accessible from the coin exit port. Blinding the opto sensor with an external infra-red ray of light is detected. Hopper will stop and generate an error.

The opto sensor uses 2 ir-leds for wide coin detection range and emit randomized IR-pulses making tampering very difficult.

Supplied with standard quick-fit and release plate.

Features:

- Compatible with other popular hopper devices.
- One configuration for Euro coins. €020 to €2.00 coins.
- Disk can reach a payout speed of 7 coins per second for Euro's.
- 3 different cup extensions. Small medium and large.
- Reliable through hole coin disk design.
- Clean design no external wires run for level sensors.
- Integrated fall tube for simple dual hopper cabinet construction.
- Standard parallel with 3 different start control signals (negative, positive and pulse).
- Power supply 12 or 24Vdc.
- Full bridge Mos-Fet motor drive.
- Pulse Width Modulated (20kHz) motor control giving:
 - constant pay out speed control.
 - low motor start-up current, prevents systems power-dips.
- Continuous opto sensor check.
- High security coin exit output
- High sensitive opto sensor
- Anti-jam operation prevents hopper blocking.
- Low level sense are standard on the Flow hopper.
- Hi level sense are optional on the Flow hopper.
- Parallel interface with standard 10pin connector.
- Coin exit output active low or active high.
- Direct power, logic signal and pulsed signal hopper control.
- Competitively priced.

Attention!

Always turn power off before removing or installing the hopper in order to prevent any damage due to surge currents!

2. Change hopper for different coin sizes.

The hopper is configured to accept most Euro coins (€0,20 to €2.00) and the British Pound. For special situations there are other disks available adapt the hopper to other coins. Changing configuration requires removing the cup and changing two parts, the payout disk and the insert plate. For correct parts for you coin see the following two tables.

Payout discs				
Mark	Diameter (mm)	Thickness (mm)	Part no	Currency
13	16.00-18.99	1.50-2.09	18-0020-13	€0.01 €0.02
14	19.00-21.99	1.50-2.09	18-0020-14	€0.05 €0.10
15	22.00-28.49	1.50-2.09	18-0020-15	
16	28.50-32.00	1.50-2.09	18-0020-16	
23	16.00-18.99	2.10-3.20	18-0020-23	
24	19.00-21.99	2.10-3.20	18-0020-24	
25	22.00-28.49	2.10-3.20	18-0020-25	€0.20 €0.50 €1.00 €2.00 £1.00
26	28.50-32.00	2.10-3.20	18-0020-26	

Table 1: Payout discs

Coin insert plates			
Mark	Diameter (mm)	Part no	Currency
3	16.00-18.99	18-0010-3	€0.01 €0.02
4	19.00-21.99	18-0010-4	€0.05 €0.10
5	22.00-28.49	18-0010-5	€0.20 €0.50 €1.00 €2.00 £1.00
6	28.50-32.00	18-0010-6	

Table 2: Coin insert plates

2.1. Hopper disassembly

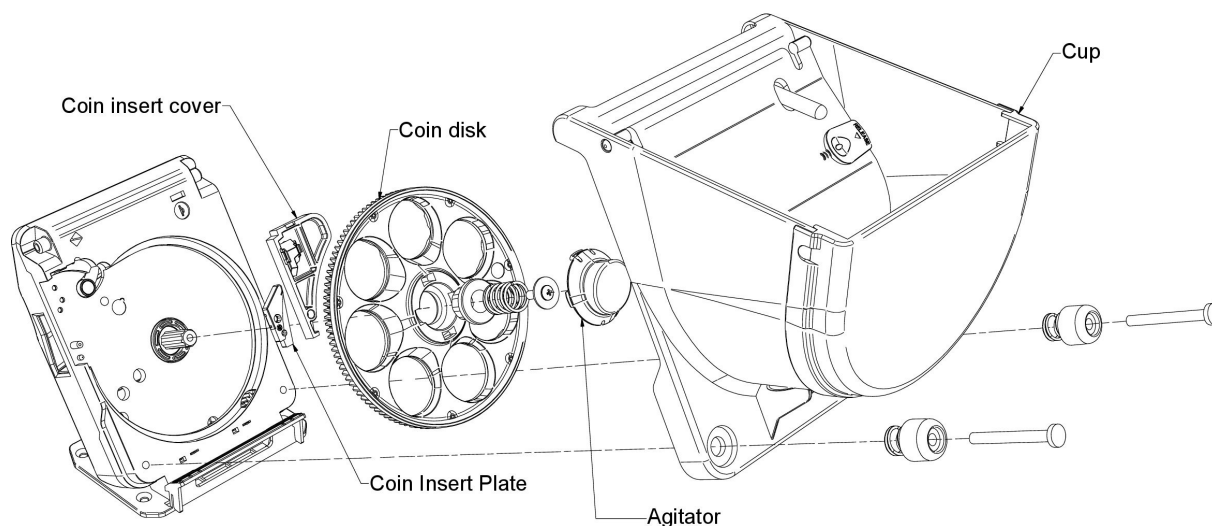

Figure 1.

1. Remove the two screws at the bottom of the cup.
2. You can now lift the cup of the hopper.
3. Use a flat screw driver to remove the agitator.
4. You can now loosen the screw and remove the coin disk.
5. The coin insert cover can now be removed.
6. You can now switch the coin insert plate.

To reassemble place the correct coin insert plate and disk. Then follow the above steps in reverse order.

3. Parallel protocol

3.1. Parallel protocol selection

You can select between several hopper protocols for optimal compatibility with excising machines. There are jumpers at the rear of the hopper where the protocol can be selected. First remove the rear cover to access the connector area. Next remove the jumper cover.

Attention: Do not confuse the jumper connector with the 6-pins factory programming connector near the 10-pins hopper interface connector.

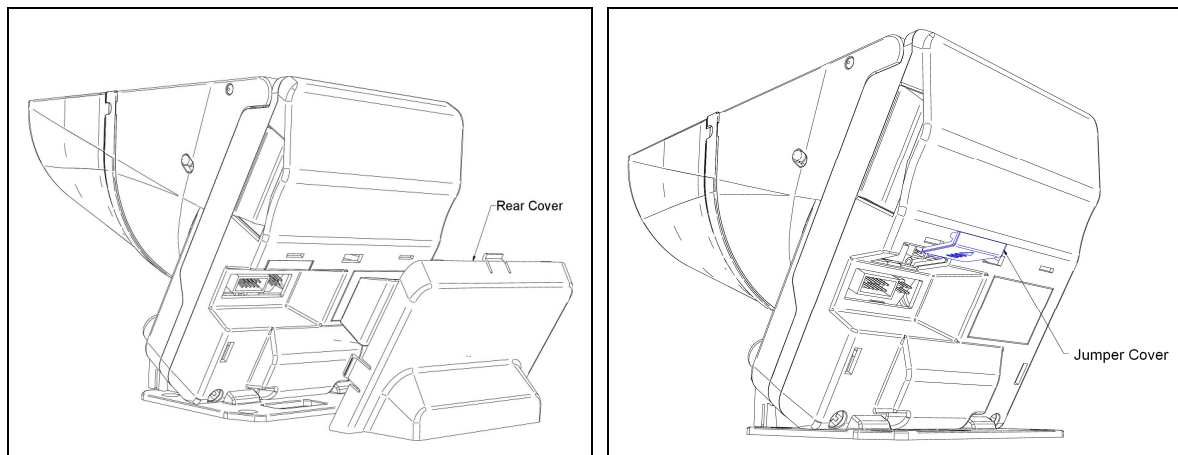



3.2. Jumper settings

Attention!

All Flow hoppers leave the factory with negative logic control setting!

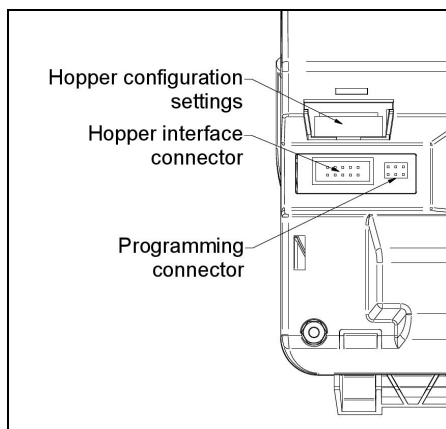
The hopper models are equipped with jumpers located inside the hopper. With the jumper “Hopper configuration setting” you can set different parallel protocols.

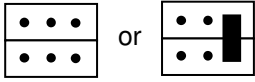

Hopper configuration setting	Mode
	Control with negative logic control signal. Jumper Cap is only placed for storage reason.
	Control with positive logic control signal
	Control by pulse

3.3. logic control signal active low

In this operation mode, the machine activates the hopper and starts paying coins when a logic low (<2.0 volts) is applied on pin 7 (control) of the connector, and stops it when a logic high (voltage between 4 and 40 volts) is on pin 7 of the connector or disconnect the pin.

3.4. logic control signal active high

The operating principle is the same as above, the only difference being that inverted logic is used. The machine activates the hopper and starts paying coins when a logic high (voltage between 4 and 40 volts) is on pin 7 (control) of the connector, and stops it when a logic low (<2.0 volts) is on pin 7 of the connector.

3.5. direct (power) control

The hopper can be started and stopped by switching the power on pins 1 and 2 on and off. The control input (pin 7) should be set active low or active high continuously in this mode. Note that logic power on pin 3 may be used also, to maintain power on the electronics when the motor power on pin 1 en 2 is switched off. In this situation the opto-sensor, coin exit and error outputs remain active.

3.6. pulsed control mode

When this operating mode is used, the hopper starts paying by applying pulses on pin 7 (control) of the connector. The control signal has a debounce time interval of 5ms. Recommended is to use an active low pulse larger or equal then 10ms. Active high pulses can also be applied. Note that hopper will start as soon as the level becomes high. Time between pulses should be larger or equal then 10 ms. For each pulse one coin is paid.

Hopper starts at rising edge of the pulse control signal. If the standby level of the pulse control signal is low, the hopper will start as soon as the level rises to high. If the standby level of the pulse control signal is high as in Fig. 1, the hopper will start as soon as the level has gone low and high again.

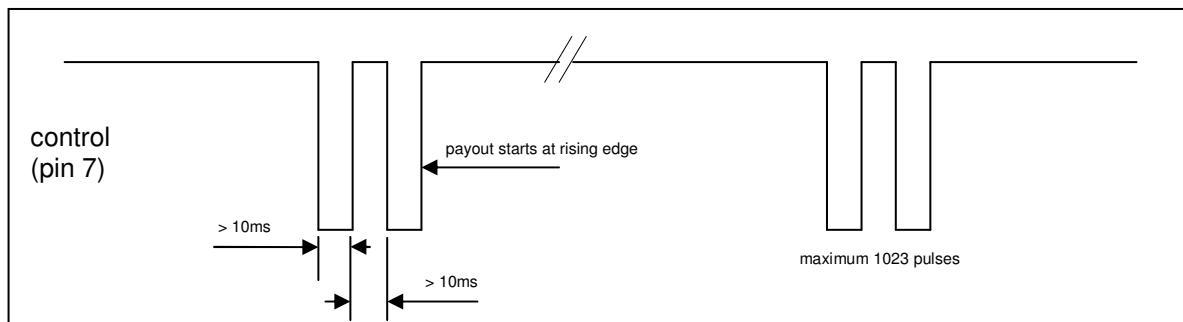
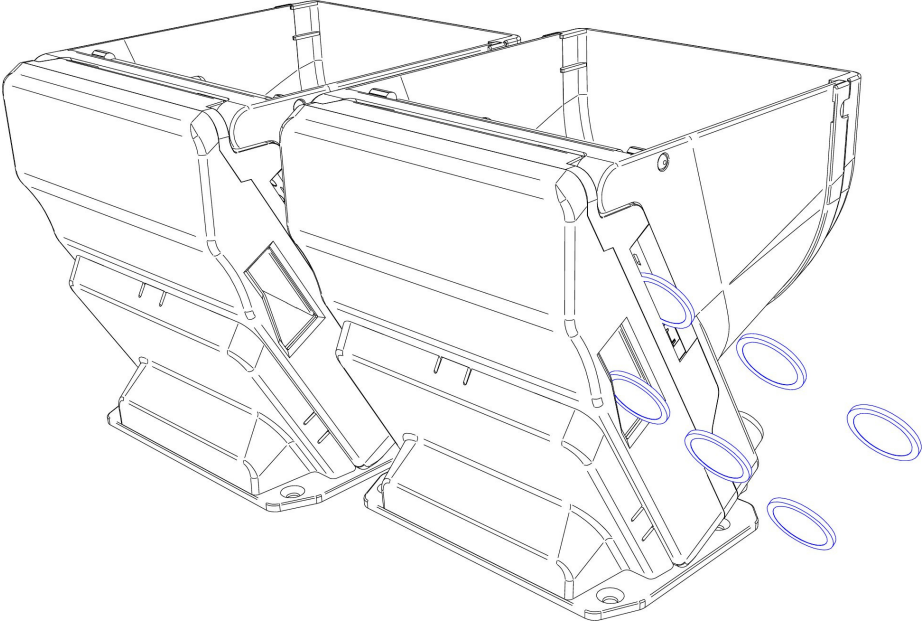

Fig. 1: Pulse timing in hopper pulsed control

4. In-Line configuration

Two hoppers can be placed next to each other for optimal use of space inside a cabinet. The hopper has a fall tube integrated in the rear of the housing.



5. Interface description

- +12Vdc or +24Vdc nominal supply
- +5V control input pull-up
- +5V coin exit output pull-up
- Error output and Coin Exit output are open collector outputs

5.1. Parallel Connector Pinout

Connector type: Molex 8624 series or similar(10 pins (2x5) of 2.5mm).
 Be careful with the pin numbering of the connector, because not all manufacturers start numbering from the same pin.

Pin	Function
1	Vdc
2	Vdc
3	Vlogic
4	0V
5	0V
6	Hi Level
7	Control
8	Error
9	Coin Exit
10	Low Level

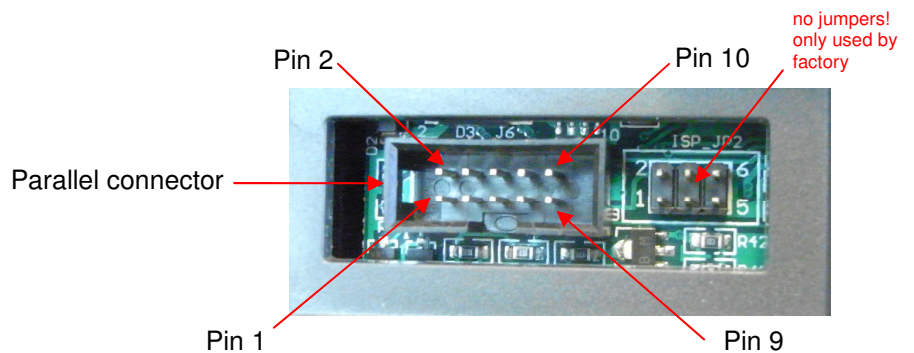

Table 3: Connector pin out

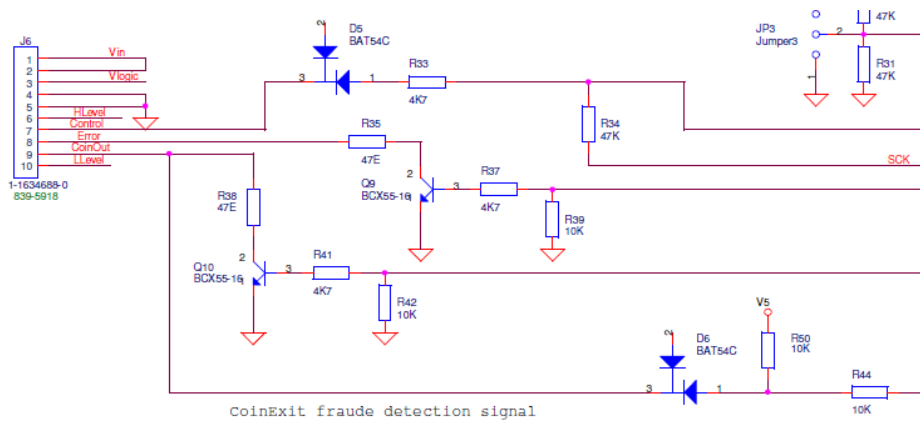

Fig. 2: Parallel interface circuit

The hopper is powered via pins 1 and 2 (motor driver) and optional via pin 3 (logic). Applications where the hopper is started and stopped by switching the power off (control pin continuous active) may consider using pins 1 and 2 to start and stop the motor and leave pin 3 powered, so that the logic remains active and opto-sensor checking and coin exit and error outputs remain active. If pin 3 is not powered, the electronics logic will be supplied by the motor power, and switched on/off together with the motor power.

5.2. Coin Jams during payout

During a payout, a coin may block the hopper (for example if the hopper is loaded too heavily, or a wrong coin has slipped into the hopper). In this case the motor current will rise quickly. A fully blocked hopper motor will draw peak currents up to 6 Amp. When the power supply is not able to deliver this peak current, the voltage on the hopper will drop.

If the motor current is greater than approx 3A during 500-800 ms, the motor will start reversing in order to un-jam the hopper. During anti-jamming, the current may rise to levels of 6 Amp peak.

If no coins are ejected during 20 seconds of anti-jamming, the hopper will abort (preventing hopper damage) and will send an error code over the error output.

5.3. Power failures

If the voltage drops below the POWER_FAIL_THRESHOLD during 10ms, the hopper will stop immediately if it was running. If the power recovers to its normal level and the start condition is still present, the hopper will restart automatically again. The amount of coins to pay when used in pulsed mode is lost when the power drops to 0V, but is retained when the power drop is not below 5V.

5.4. Level sensing

The hopper has 2 level output pins: pin 6 for high level and pin 10 for low level. The level outputs act as switches to ground.

The low level pin 10 is connected to a metal sense plate inside the bottom of the coin cup. When the coin is not empty, the low level sense plate makes contact via the coins and pin 9 will be shorted to ground.

The high level pin 6 is connected to a metal sense plate on top of the coin cup. When the hopper is filled to the top, the high level sense plate makes contact via the coins and pin 6 will be shorted to ground.

Note the hopper level sensing only works for metal coins.

5.5. Coin exit output

The Coin Exit output is an open collector output, pulled up internally to 5V via a diode. This diode prevents current flowing into the hopper if the coin exit output is pulled up to higher voltages.

The coin exit output is protected against shorting it to a high level voltage. If the output is shorted to a high level voltage (fraud attempt), the hopper will stop as soon as a coin passes the opto sensor, preventing more coins to be ejected. Error code 1 will be transmitted over the error output.

If the coin exit is shorted to ground for more than 1 sec, error code 1 will also be transmitted over the error output.

When a coin passes the coin opto sensor, the coin exit output will go low. It goes up again as soon as the coin leaves the opto sensor. The coin exit signal does not need to be debounced.

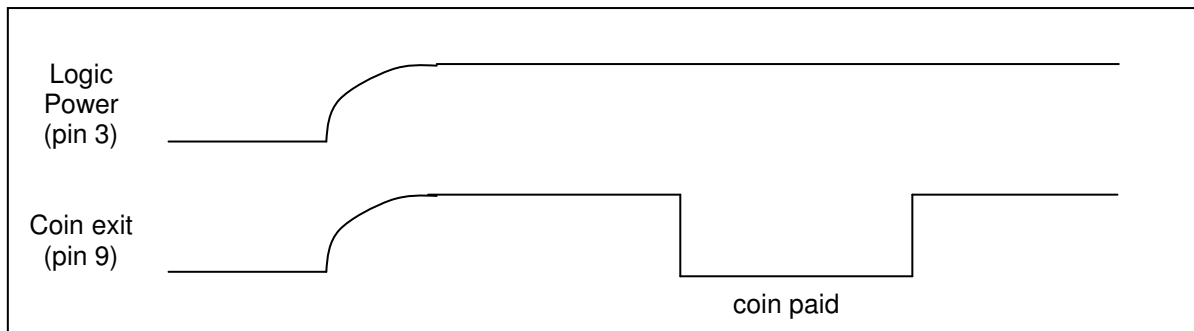

Fig. 3: Coin exit active low timing (internal pulled up)

If jumper JP4 is shorted, then the coin exit output signal becomes active high. Jumper JP4 is a 2-pins header located at the most right side under the jumper cover.

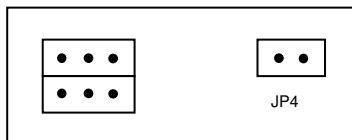

Fig. 4: Jumper JP4 location (short for active high coin exit output)

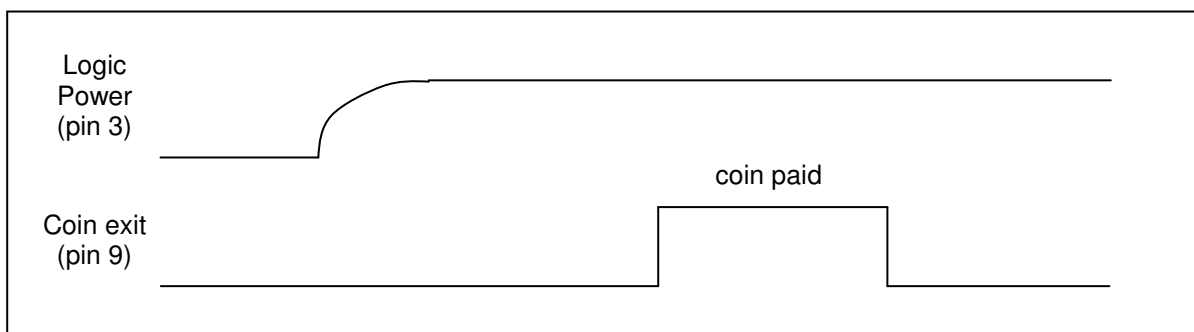

Fig. 5: Coin exit active high timing (internal pulled up)

5.6. Error output

The error output is an open collector output, and is not internally pulled up, so it must be pulled up externally.

When the hopper detects a problem, an error code is transmitted over the error output line (pin 8 of the hopper connector). It is recommended that the host machine inspects the error signal for any errors present. The error code is equal to the number of error pulses transmitted. (see Fig. 6 for an example of code 3).

If the hopper is started, the previous error is cleared automatically.

Table 4: Error codes Table 4 lists all error codes and their meaning.

Error code	Description	Meaning
1	Coin exit output error	- Coin exit pulse became longer than 1000 ms - Coin exit didn't go low when a coin was ejected (tampering?)
2	Overpay error	- Opto sensor detected a coin with the hopper in idle state.
3	Permanent jam.	- Hopper reversed 10 times or more during 20 sec, without resolving the jam.
4	Payout timeout	- No coins were paid within 25 seconds after the hopper was started. Hopper has stopped. (only active in hopper pulsed mode).
5	Motor not detected	- Motor current was too low during start.
6	Opto sensor failure	- Opto sensor was blocked for more than 1 second - Opto sensor self test failed (dirty sensor, opto alignment problem) - Opto sensor was blinded (fraud attempt)
7	General hopper failure	- Should not happen normally. Inspect or replace PCB

Table 4: Error codes

In idle state the error output is high. A time delay of 100 ms is inserted before the pulse train is send. So the error code repeats itself each 100ms. The pulses itself are 10ms high followed by 10ms low.

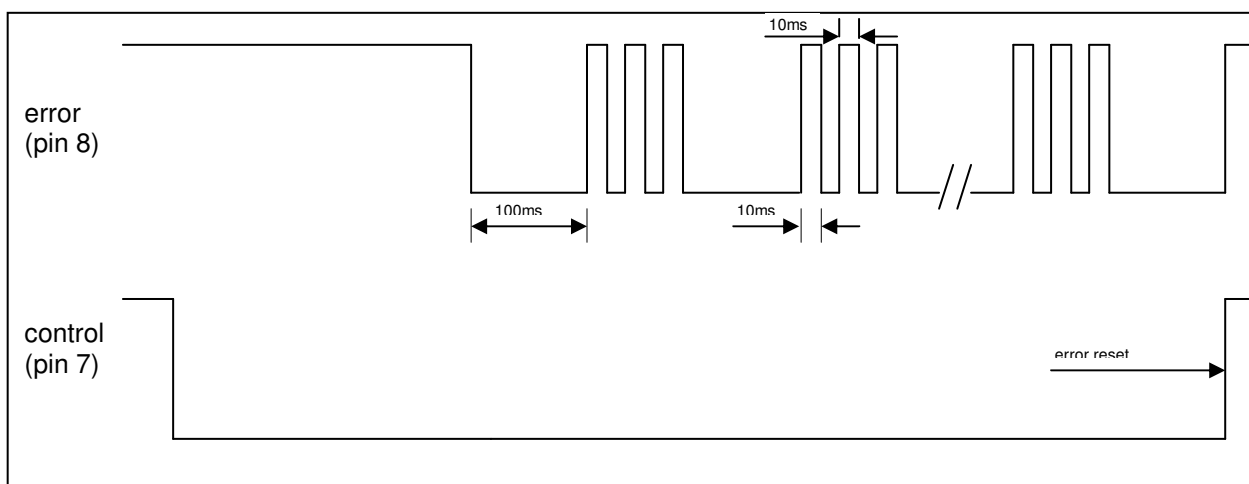

Fig. 6: Error code 3 pulse timing

6. Electronics

6.1. specification Electrical, Timing and Environmental Specifications

Parameter	Min	Typ @ 12V	Typ @ 24V	Max	Units
Supply voltage	11	12	24	26	Vdc
Idle current		30	30		mA
Motor_start current		2.2	2.2	5	A
Motor_running_current		0.5	0.6	0.9	A
Vtrip (Power fail threshold)		7.0 during 10ms	7.0 during 10ms		Vdc
Motor_current_reverse level		> 3.0 A during 800 ms	> 3.0 A during 500 ms		A
Thermal fuse protection		5.5	5.5		A

Table 5: Electrical specifications

Storage temperature	-20° C to +70° C
Operating temperature	0° C to +50°C
Storage humidity	10% to 95% non-condensing
Operating humidity	10% to 75% RH
General	Keep coin exit clear from any obstacles

Table 6: Environmental specifications

7. Warranty

We thank you for the purchase of this Suzo product. If you require warranty for this product you can contact Suzo International. Before contacting Suzo we advise to carefully read the product manual.

7.1. Your warranty

Suzo guaranties that the product for the period of ONE YEAR from the original purchase date will be free of material or fabrication errors. When material or fabrication errors do occur (as judged by Suzo) within the warranty period, Suzo will replace or repair the defective parts without labour cost or parts cost. The following restrictions apply. All replaced products or parts become property of Suzo International.

7.2. Conditions

1. Warranty can only apply when the original invoice (with model number and purchase date) together with the defective product is presented within the warranty period.
2. Suzo is under no obligation to perform warranty when invoice is not present or unreadable.
3. Warranty does not apply when model number of serial of product are changed, removed or made unreadable.
4. Warranty does not cover the risk to the product during transportation to and from Suzo International
5. Warranty does not cover:
 - a. Regular maintenance or replacement of parts due to normal wear.
 - b. Damage of defects caused by operation or treatment of the product not considered as normal use.
 - c. Damage or adaptations to the product caused by faulty operation or use that is not within the machines original capabilities.
6. Warranty is only performed at the Suzo Technical office unless other official agreements apply for instance as agreed upon in a maintenance contract.

8. Dimensions

8.1. General dimensions

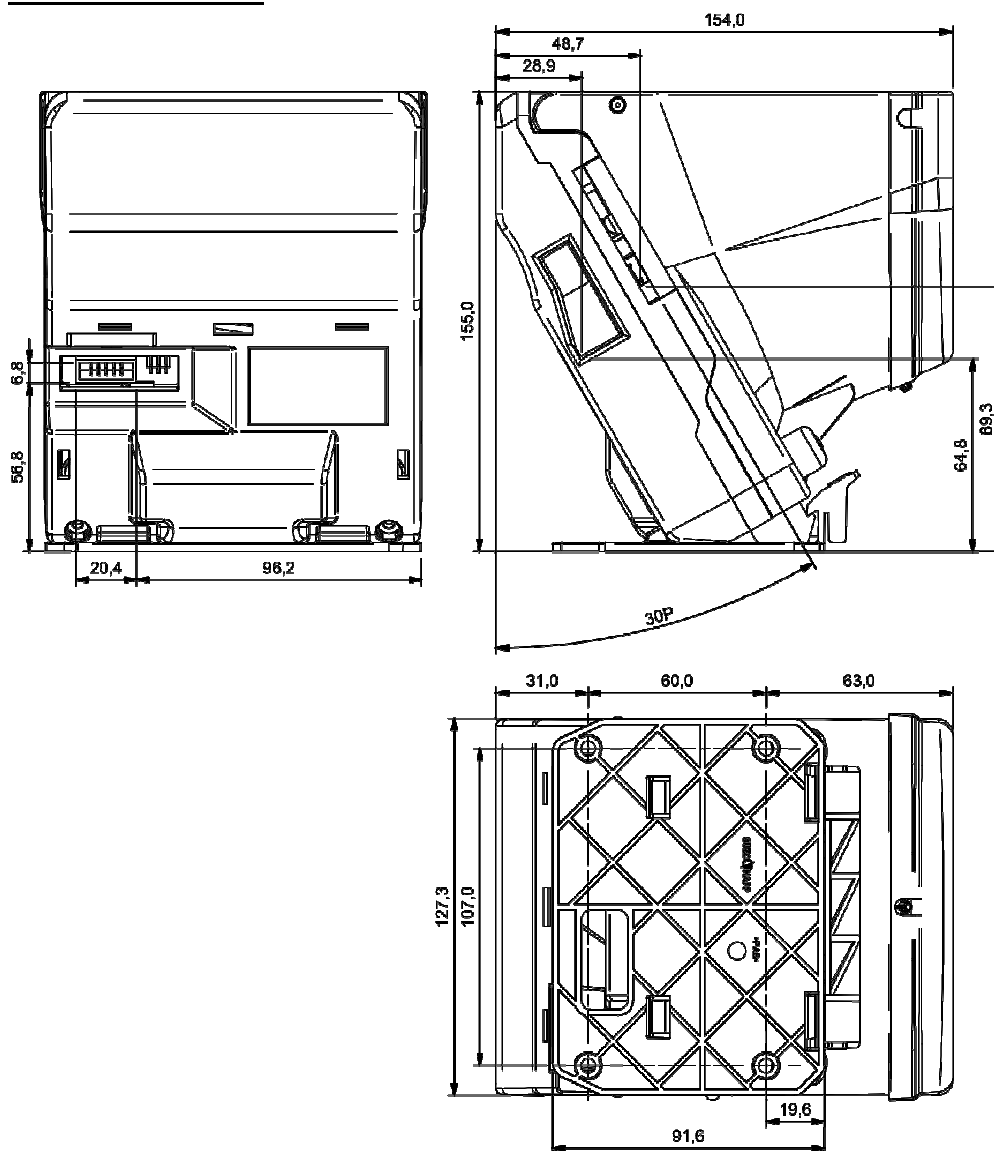

8.2. Medium and large Extensions

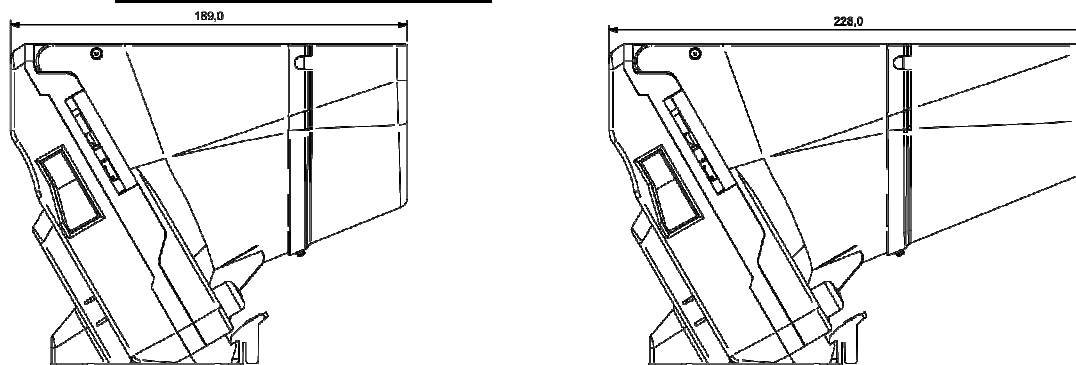

Revision History

Revision	Date	Comment	By
0.1	09 Jul. 2010	Pre release	E.S.
0.2	29 Sept 2010	Drawings	M.M.
0.3	29 Nov 2010	Update exploded views	E.S.
0.4	26 Jan 2011	Added error codes text.	R.T.
0.5	2 Febr 2011	More exploded views added. Interface described in more detail.	E.S. R.T.

Design and specifications are subject to change without notice.
Wijzigingen in ontwerp en technische gegevens voorbehouden, zonder kennisgeving.
La conception et les spécifications sont modifiables sans préavis.
El diseño y especificaciones están sujetos a cambios sin previo aviso.

This manual is intended only to assist the reader in the use of this product and therefore Suzo International shall not be held liable for any loss or damage whatsoever arising from the use of any information or particulars in, or any omission from this manual or any incorrect use of the product.

Warning!

Failure to observe the interface requirements specified in this technical manual may result in miscounts, damage to the electronics and the motor of the hopper or create unacceptable voltage drops, affecting other units depending on the same power supply.